

PROJECT MANUAL

Tyger River CBED Renovation
State of SC Project No. H59-6088-JM
EDA Investment No: 04-01-06828

Architect's Project No: 14042

Spartanburg Community College

1875 E. Main St. (Hwy 290)

Duncan, SC 29334

Construction Documents

June 3, 2015

CRAIG GAULDEN DAVIS

● Architecture Planning Interiors

SECTION 001000 - SEALS PAGE



TYGER RIVER CBED RENOVATION SPARTANBURG COMMUNITY COLLEGE

OSE PROJECT NO. H59-6088-JM

CGD PROJECT NO.: 14042

ISSUE DATE: 06/03/2015

SPECIFICATION INDEX

Project Title Page
Seals Page
Specification Index
Invitation for Construction Services- Request for Advertisement **(SE-310)**
Instructions to Bidders **(AIA Document A701 – 1997 Edition)**
Standard Supplemental Instructions to Bidders **(00201-OSE)**
Bid Bond **(AIA Document A310-2010)**
Lump Sum Bid Form **(SE-330)**
Standard Form of Agreement Between Owner and Contractor **(AIA Document A101 - 2007 Edition)**
Standard Modifications to Agreement Between Owner and Contractor **(00501-OSE)**
General Conditions of the Contract for Construction **(AIA Document A201 – 2007 Edition)**
Standard Supplementary Conditions **(00811-OSE)**
Performance Bond **(SE-355)**
Labor and Material Payment Bond **(SE-357)**
Digital Transfer Agreement
EDA Contracting Provisions for Construction Projects - US Department of Commerce
EDA Construction Site Sign Specifications
Notice of Requirements for Affirmative Action to Ensure Equal Employment
Certification Regarding Lobbying Restrictions - US Department of Commerce
Davis/Bacon Wage Rates (General Decision Number: SC150036)
Buy American Clause

TECHNICAL SPECIFICATIONS

**DIVISION
NUMBER DIVISION AND SECTION TITLES**

Div 1	<u>General Requirements</u> 011000 - Summary 012300 - Alternates 012900 - Payment Procedures 013100 - Project Management and Coordination 013300 - Submittal Procedures 014000 - Quality Requirements 014200 - References 015000 - Temporary Facilities and Controls Project Sign Template 016000 - Product Requirements Request for Substitution Form 017300 - Execution 017700 - Closeout Procedures 017823 - Operation and Maintenance Data 017839 - Project Record Documents
Div 2	<u>Existing Conditions</u> 024119 - Selective Demolition
Div 3	<u>Concrete</u> 033000 - Cast-In-Place Concrete
Div 4	<u>Masonry</u> 042000 - Unit Masonry

**Tyger River CBED Renovation
Spartanburg Community College**

Specification Index

Page 2 of 4

DIVISION NUMBER	DIVISION AND SECTION TITLES
Div 5	<u>Metals</u> 051200 - Structural Steel Framing 052100 - Steel Joist Framing 053100 - Steel Decking 055000 - Metal Fabrications
Div 6	<u>Wood, Plastics and Composites</u> 061053 - Miscellaneous Rough Carpentry 064116 - Plastic-Laminate-Faced Architectural Cabinets
Div 7	<u>Thermal and Moisture Protection</u> 072100 - Thermal Insulation 076200 - Sheet Metal Flashing and Trim 078413 - Penetration Fire stopping 078446 - Fire-Resistive Joint Systems 079200 - Joint Sealants
Div 8	<u>Openings</u> 081113 - Hollow Metal Doors and Frames 081416 - Flush Wood Doors 084113 - Aluminum-Framed Entrances and Storefronts 087100 - Door Hardware 088000 - Glazing
Div 9	<u>Finishes</u> 092216 - Non-Structural Metal Framing 092900 - Gypsum Board 093000 - Tiling 095113 - Acoustical Panel Ceilings 096513 - Resilient Base and Accessories 096519 - Resilient Tile Flooring 096813 - Tile Carpeting 097200 - Wall Coverings 098400 - Metal Wall System 099123 - Interior Painting 099300 - Staining and Transparent Finishing
Div 10	<u>Specialties</u> 101423 - Panel Signage 102113 - Toilet Compartments 102800 - Toilet, Bath and Laundry Accessories 104413 - Fire Extinguisher Cabinets 104416 - Fire Extinguishers
Div 11	<u>Equipment</u> Not Used
Div 12	<u>Furnishings</u> 122113 - Horizontal Louver Blinds

**Tyger River CBED Renovation
Spartanburg Community College**

Specification Index

Page 3 of 4

DIVISION NUMBER	DIVISION AND SECTION TITLES
Div 13	<u>Special Construction</u> Not Used
Div 14	<u>Conveying Equipment</u> Not Used
Div 21	<u>Fire Suppression</u> 21 1313 Fire Suppression Piping Fire Protection Sprinkler System Specification Sheet
Div 22	<u>Plumbing</u> 22 0500 - Common Work Results For Plumbing 22 0529 - Hangers And Supports For Plumbing Piping And Equipment 22 0553 - Identification For Plumbing Piping And Equipment 22 0700 - Plumbing Insulation 22 1116 - Domestic Water Piping 22 1316 - Sanitary Waste & Vent Piping 22 1319 - Sanitary Waste Piping Specialties 22 4000 - Plumbing Fixtures
Div 23	<u>Heating, Ventilating and Air Conditioning and Plumbing</u> 23 0500 - Common Work Results for HVAC 23 0529 - Hangers and Supports for HVAC Piping and Equipment 23 0553 - Identification For HVAC Piping and Equipment 23 0593 - Testing, Adjusting, and Balancing for HVAC 23 0700 - HVAC Insulation 23 3113 - Metal Ducts 23 3300 - Air Duct Accessories 23 3423 - HVAC Power Ventilators 233713 - Diffusers, Registers, and Grilles 237313 - Split System Heat Pump Units
Div 25	<u>Integrated Automation</u> Not Used
Div 26	<u>Electrical</u> 260500 - Common Work Results For Electrical 260519 - Low-Voltage Electrical Power Conductors And Cables 260526 - Grounding And Bonding For Electrical Systems 260529 - Hangers and Supports For Electrical Systems 260533 - Raceway And Boxes For Electrical Systems 260543 - Underground Ducts and Raceways For Electrical Systems 260553 - Identification For Electrical Systems 260574 - Overcurrent Protective Device Arc-Flash Study 260923 - Lighting Control Devices 262413 - Switchboards 262416 - Panelboards 262726 - Wiring Devices 262813 - Fuses 262816 - Enclosed Switches And Circuit Breakers 262913 - Enclosed Controllers 265100 - Interior Lighting
Div 27	<u>Communications</u> Not Used
Div 28	<u>Electronic Safety and Security</u> 283111 - Digital, Addressable Fire-Alarm System

Specification Index

DIVISION NUMBER	DIVISION AND SECTION TITLES
Div 31	<u>Earthwork</u> Not Used
Div 32	<u>Exterior Improvements</u> Not Used
Div 33	<u>Utilities</u> Not Used
Div 34	<u>Transportation</u> Not Used
Div 35	<u>Waterway and Marine</u> Not Used
Div 40	<u>Process Integration</u> Not Used
Div 41	<u>Material Processing and Handling Equipment</u> Not Used
Div 42	<u>Process Heating, Cooling and Drying Equipment</u> Not Used
Div 43	<u>Process Gas and Liquid Handling, Purification and Storage Equipment</u> Not Used
Div 44	<u>Pollution Control Equipment</u> Not Used
Div 45	<u>Industry-Specific Manufacturing Equipment</u> Not Used
Div 48	<u>Electrical Power Generation</u> Not Used

SE-310
REQUEST FOR ADVERTISEMENT

2011 Edition
Rev. 7/28/2014

PROJECT NAME: Tyger River CBED Renovation

PROJECT NUMBER: H59-6088-JM

PROJECT LOCATION: Spartanburg Community College - Tyger River Campus, 1875 E. Main Street, Duncan, SC 29334

Contractor may be subject to performance appraisal at close of project

BID SECURITY REQUIRED? Yes No

PERFORMANCE & PAYMENT BONDS REQUIRED? Yes No

CONSTRUCTION COST RANGE: \$1,000,000 to \$1,500,000

DESCRIPTION OF PROJECT: Complete interior renovation of a portion of an existing campus building to include selective demolition, new interior partitions, doors, windows, finishes, ceilings, mechanical systems, lighting, power, data and fire protection systems. The U.S. Department of Commerce Economic Development Administration is providing partial funding for this project (EDA Investment No. 04-01-06828).

A/E NAME: Craig Gaulden Davis

A/E CONTACT: David Dixon

A/E ADDRESS: Street/PO Box: 19 Washington Park

City: Greenville

State: SC ZIP: 29601-

EMAIL: ddixon@cgdarch.com

TELEPHONE: 864-242-0761

FAX: 864-501-9945

All questions & correspondence concerning this Invitation shall be addressed to the A/E.

BIDDING DOCUMENTS/PLANS MAY BE OBTAINED FROM: Craig Gaulden Davis

PLAN DEPOSIT AMOUNT: \$150.00 **IS DEPOSIT REFUNDABLE:** Yes No

Only those Bidding Documents/Plans obtained from the above listed source(s) are official. Bidders rely on copies of Bidding Documents/Plans obtained from any other source at their own risk.

BIDDING DOCUMENTS/PLANS ARE ALSO ON FILE FOR VIEWING PURPOSES ONLY AT *(list name and location for each plan room or other entity):*

Associated General Contractors - AGC online, McGraw Hill Construction - Dodge online & Reed Construcion Data

PRE-BID CONFERENCE? Yes No **MANDATORY ATTENDANCE?** Yes No

DATE: 6/16/2015 **TIME:** 10:00 AM **PLACE:** SCC Tyger River Building, 1875 E. Main Street, Duncan, SC

AGENCY: Spartanburg Community College

NAME OF AGENCY PROCUREMENT OFFICER: Gladden Smoke

ADDRESS: Street/PO Box: PO Box 4386

City: Spartanburg

State: SC ZIP: 29305-

EMAIL: smokeg@scsc.edu

TELEPHONE: 864-592-4157

FAX: 864-592-4753

BID CLOSING DATE: 6/30/2015 **TIME:** 2:00 PM **LOCATION:** SCC Campus Operations, 136 Community College Drive, Spartanburg, SC 29303

BID DELIVERY ADDRESSES:

HAND-DELIVERY:

Attn: Gladden Smoke

Spartanburg Community College

Campus Operations

136 Community College Drive

Spartanburg, SC 29303

MAIL SERVICE:

Attn: Gladden Smoke

Spartanburg Community College

PO Box 4386

Spartanburg, SC 29303

IS PROJECT WITHIN AGENCY CONSTRUCTION CERTIFICATION? (Agency MUST check one) Yes No

APPROVED BY *(Office of State Engineer):* _____ **DATE:** _____

DRAFT AIA® Document A701™ - 1997

Instructions to Bidders

for the following PROJECT:

(Name and location or address)

«Tyger River CBED Renovation»
«Spartanburg Community College
Tyger River Campus
Duncan, South Carolina
[H59-6088-JM](#)
»

THE OWNER:

(Name, legal status and address)

« [Spartanburg Community College](#)
[Post Office Drawer 4386](#)
[Spartanburg, South Carolina 29305](#) »« »
« »

THE ARCHITECT:

(Name, legal status and address)

«[Craig Gauden Davis, Inc.](#)
[19 Washington Park](#)
[Greenville, South Carolina 29601](#) »« »
« »

TABLE OF ARTICLES

- 1 DEFINITIONS
- 2 BIDDER'S REPRESENTATIONS
- 3 BIDDING DOCUMENTS
- 4 BIDDING PROCEDURES
- 5 CONSIDERATION OF BIDS
- 6 POST-BID INFORMATION
- 7 PERFORMANCE BOND AND PAYMENT BOND
- 8 FORM OF AGREEMENT BETWEEN OWNER AND CONTRACTOR

ADDITIONS AND DELETIONS:

The author of this document has added information needed for its completion. The author may also have revised the text of the original AIA standard form. An *Additions and Deletions Report* that notes added information as well as revisions to the standard form text is available from the author and should be reviewed.

This document has important legal consequences. Consultation with an attorney is encouraged with respect to its completion or modification.

ELECTRONIC COPYING of any portion of this AIA® Document to another electronic file is prohibited and constitutes a violation of copyright laws as set forth in the footer of this document.

ARTICLE 1 DEFINITIONS

§ 1.1 Bidding Documents include the Bidding Requirements and the proposed Contract Documents. The Bidding Requirements consist of the Advertisement or Invitation to Bid, Instructions to Bidders, Supplementary Instructions to Bidders, the bid form, and other sample bidding and contract forms. The proposed Contract Documents consist of the form of Agreement between the Owner and Contractor, Conditions of the Contract (General, Supplementary and other Conditions), Drawings, Specifications and all Addenda issued prior to execution of the Contract.

§ 1.2 Definitions set forth in the General Conditions of the Contract for Construction, AIA Document A201, or in other Contract Documents are applicable to the Bidding Documents.

§ 1.3 Addenda are written or graphic instruments issued by the Architect prior to the execution of the Contract which modify or interpret the Bidding Documents by additions, deletions, clarifications or corrections.

§ 1.4 A Bid is a complete and properly executed proposal to do the Work for the sums stipulated therein, submitted in accordance with the Bidding Documents.

§ 1.5 The Base Bid is the sum stated in the Bid for which the Bidder offers to perform the Work described in the Bidding Documents as the base, to which Work may be added or from which Work may be deleted for sums stated in Alternate Bids.

§ 1.6 An Alternate Bid (or Alternate) is an amount stated in the Bid to be added to or deducted from the amount of the Base Bid if the corresponding change in the Work, as described in the Bidding Documents, is accepted.

§ 1.7 A Unit Price is an amount stated in the Bid as a price per unit of measurement for materials, equipment or services or a portion of the Work as described in the Bidding Documents.

§ 1.8 A Bidder is a person or entity who submits a Bid and who meets the requirements set forth in the Bidding Documents.

§ 1.9 A Sub-bidder is a person or entity who submits a bid to a Bidder for materials, equipment or labor for a portion of the Work.

ARTICLE 2 BIDDER'S REPRESENTATIONS

§ 2.1 The Bidder by making a Bid represents that:

§ 2.1.1 The Bidder has read and understands the Bidding Documents or Contract Documents, to the extent that such documentation relates to the Work for which the Bid is submitted, and for other portions of the Project, if any, being bid concurrently or presently under construction.

§ 2.1.2 The Bid is made in compliance with the Bidding Documents.

§ 2.1.3 The Bidder has visited the site, become familiar with local conditions under which the Work is to be performed and has correlated the Bidder's personal observations with the requirements of the proposed Contract Documents.

§ 2.1.4 The Bid is based upon the materials, equipment and systems required by the Bidding Documents without exception.

ARTICLE 3 BIDDING DOCUMENTS

§ 3.1 COPIES

§ 3.1.1 Bidders may obtain complete sets of the Bidding Documents from the issuing office designated in the Advertisement or Invitation to Bid in the number and for the deposit sum, if any, stated therein. The deposit will be refunded to Bidders who submit a bona fide Bid and return the Bidding Documents in good condition within ten days after receipt of Bids. The cost of replacement of missing or damaged documents will be deducted from the deposit. A Bidder receiving a Contract award may retain the Bidding Documents and the Bidder's deposit will be refunded.

§ 3.1.2 Bidding Documents will not be issued directly to Sub-bidders unless specifically offered in the Advertisement or Invitation to Bid, or in supplementary instructions to bidders.

§ 3.1.3 Bidders shall use complete sets of Bidding Documents in preparing Bids; neither the Owner nor Architect assumes responsibility for errors or misinterpretations resulting from the use of incomplete sets of Bidding Documents.

§ 3.1.4 The Owner and Architect may make copies of the Bidding Documents available on the above terms for the purpose of obtaining Bids on the Work. No license or grant of use is conferred by issuance of copies of the Bidding Documents.

§ 3.2 INTERPRETATION OR CORRECTION OF BIDDING DOCUMENTS

§ 3.2.1 The Bidder shall carefully study and compare the Bidding Documents with each other, and with other work being bid concurrently or presently under construction to the extent that it relates to the Work for which the Bid is submitted, shall examine the site and local conditions, and shall at once report to the Architect errors, inconsistencies or ambiguities discovered.

§ 3.2.2 Bidders and Sub-bidders requiring clarification or interpretation of the Bidding Documents shall make a written request which shall reach the Architect at least seven days prior to the date for receipt of Bids.

§ 3.2.3 Interpretations, corrections and changes of the Bidding Documents will be made by Addendum. Interpretations, corrections and changes of the Bidding Documents made in any other manner will not be binding, and Bidders shall not rely upon them.

§ 3.3 SUBSTITUTIONS

§ 3.3.1 The materials, products and equipment described in the Bidding Documents establish a standard of required function, dimension, appearance and quality to be met by any proposed substitution.

§ 3.3.2 No substitution will be considered prior to receipt of Bids unless written request for approval has been received by the Architect at least ten days prior to the date for receipt of Bids. Such requests shall include the name of the material or equipment for which it is to be substituted and a complete description of the proposed substitution including drawings, performance and test data, and other information necessary for an evaluation. A statement setting forth changes in other materials, equipment or other portions of the Work, including changes in the work of other contracts that incorporation of the proposed substitution would require, shall be included. The burden of proof of the merit of the proposed substitution is upon the proposer. The Architect's decision of approval or disapproval of a proposed substitution shall be final.

§ 3.3.3 If the Architect approves a proposed substitution prior to receipt of Bids, such approval will be set forth in an Addendum. Bidders shall not rely upon approvals made in any other manner.

§ 3.3.4 No substitutions will be considered after the Contract award unless specifically provided for in the Contract Documents.

§ 3.4 ADDENDA

§ 3.4.1 Addenda will be transmitted to all who are known by the issuing office to have received a complete set of Bidding Documents.

§ 3.4.2 Copies of Addenda will be made available for inspection wherever Bidding Documents are on file for that purpose.

§ 3.4.3 Addenda will be issued no later than four days prior to the date for receipt of Bids except an Addendum withdrawing the request for Bids or one which includes postponement of the date for receipt of Bids.

§ 3.4.4 Each Bidder shall ascertain prior to submitting a Bid that the Bidder has received all Addenda issued, and the Bidder shall acknowledge their receipt in the Bid.

ARTICLE 4 BIDDING PROCEDURES

§ 4.1 PREPARATION OF BIDS

§ 4.1.1 Bids shall be submitted on the forms included with the Bidding Documents.

§ 4.1.2 All blanks on the bid form shall be legibly executed in a non-erasable medium.

§ 4.1.3 Sums shall be expressed in both words and figures. In case of discrepancy, the amount written in words shall govern.

§ 4.1.4 Interlineations, alterations and erasures must be initialed by the signer of the Bid.

§ 4.1.5 All requested Alternates shall be bid. If no change in the Base Bid is required, enter "No Change."

§ 4.1.6 Where two or more Bids for designated portions of the Work have been requested, the Bidder may, without forfeiture of the bid security, state the Bidder's refusal to accept award of less than the combination of Bids stipulated by the Bidder. The Bidder shall make no additional stipulations on the bid form nor qualify the Bid in any other manner.

§ 4.1.7 Each copy of the Bid shall state the legal name of the Bidder and the nature of legal form of the Bidder. The Bidder shall provide evidence of legal authority to perform within the jurisdiction of the Work. Each copy shall be signed by the person or persons legally authorized to bind the Bidder to a contract. A Bid by a corporation shall further give the state of incorporation and have the corporate seal affixed. A Bid submitted by an agent shall have a current power of attorney attached certifying the agent's authority to bind the Bidder.

§ 4.2 BID SECURITY

§ 4.2.1 Each Bid shall be accompanied by a bid security in the form and amount required if so stipulated in the Instructions to Bidders. The Bidder pledges to enter into a Contract with the Owner on the terms stated in the Bid and will, if required, furnish bonds covering the faithful performance of the Contract and payment of all obligations arising thereunder. Should the Bidder refuse to enter into such Contract or fail to furnish such bonds if required, the amount of the bid security shall be forfeited to the Owner as liquidated damages, not as a penalty. The amount of the bid security shall not be forfeited to the Owner in the event the Owner fails to comply with Section 6.2.

§ 4.2.2 If a surety bond is required, it shall be written on AIA Document A310, Bid Bond, unless otherwise provided in the Bidding Documents, and the attorney-in-fact who executes the bond on behalf of the surety shall affix to the bond a certified and current copy of the power of attorney.

§ 4.2.3 The Owner will have the right to retain the bid security of Bidders to whom an award is being considered until either (a) the Contract has been executed and bonds, if required, have been furnished, or (b) the specified time has elapsed so that Bids may be withdrawn or (c) all Bids have been rejected.

§ 4.3 SUBMISSION OF BIDS

§ 4.3.1 All copies of the Bid, the bid security, if any, and any other documents required to be submitted with the Bid shall be enclosed in a sealed opaque envelope. The envelope shall be addressed to the party receiving the Bids and shall be identified with the Project name, the Bidder's name and address and, if applicable, the designated portion of the Work for which the Bid is submitted. If the Bid is sent by mail, the sealed envelope shall be enclosed in a separate mailing envelope with the notation "SEALED BID ENCLOSED" on the face thereof.

§ 4.3.2 Bids shall be deposited at the designated location prior to the time and date for receipt of Bids. Bids received after the time and date for receipt of Bids will be returned unopened.

§ 4.3.3 The Bidder shall assume full responsibility for timely delivery at the location designated for receipt of Bids.

§ 4.3.4 Oral, telephonic, telegraphic, facsimile or other electronically transmitted bids will not be considered.

§ 4.4 MODIFICATION OR WITHDRAWAL OF BID

§ 4.4.1 A Bid may not be modified, withdrawn or canceled by the Bidder during the stipulated time period following the time and date designated for the receipt of Bids, and each Bidder so agrees in submitting a Bid.

§ 4.4.2 Prior to the time and date designated for receipt of Bids, a Bid submitted may be modified or withdrawn by notice to the party receiving Bids at the place designated for receipt of Bids. Such notice shall be in writing over the signature of the Bidder. Written confirmation over the signature of the Bidder shall be received, and date- and time-stamped by the receiving party on or before the date and time set for receipt of Bids. A change shall be so worded as not to reveal the amount of the original Bid.

§ 4.4.3 Withdrawn Bids may be resubmitted up to the date and time designated for the receipt of Bids provided that they are then fully in conformance with these Instructions to Bidders.

§ 4.4.4 Bid security, if required, shall be in an amount sufficient for the Bid as resubmitted.

ARTICLE 5 CONSIDERATION OF BIDS

§ 5.1 OPENING OF BIDS

At the discretion of the Owner, if stipulated in the Advertisement or Invitation to Bid, the properly identified Bids received on time will be publicly opened and will be read aloud. An abstract of the Bids may be made available to Bidders.

§ 5.2 REJECTION OF BIDS

The Owner shall have the right to reject any or all Bids. A Bid not accompanied by a required bid security or by other data required by the Bidding Documents, or a Bid which is in any way incomplete or irregular is subject to rejection.

§ 5.3 ACCEPTANCE OF BID (AWARD)

§ 5.3.1 It is the intent of the Owner to award a Contract to the lowest qualified Bidder provided the Bid has been submitted in accordance with the requirements of the Bidding Documents and does not exceed the funds available. The Owner shall have the right to waive informalities and irregularities in a Bid received and to accept the Bid which, in the Owner's judgment, is in the Owner's own best interests.

§ 5.3.2 The Owner shall have the right to accept Alternates in any order or combination, unless otherwise specifically provided in the Bidding Documents, and to determine the low Bidder on the basis of the sum of the Base Bid and Alternates accepted.

ARTICLE 6 POST-BID INFORMATION

§ 6.1 CONTRACTOR'S QUALIFICATION STATEMENT

Bidders to whom award of a Contract is under consideration shall submit to the Architect, upon request, a properly executed AIA Document A305, Contractor's Qualification Statement, unless such a Statement has been previously required and submitted as a prerequisite to the issuance of Bidding Documents.

§ 6.2 OWNER'S FINANCIAL CAPABILITY

The Owner shall, at the request of the Bidder to whom award of a Contract is under consideration and no later than seven days prior to the expiration of the time for withdrawal of Bids, furnish to the Bidder reasonable evidence that financial arrangements have been made to fulfill the Owner's obligations under the Contract. Unless such reasonable evidence is furnished, the Bidder will not be required to execute the Agreement between the Owner and Contractor.

§ 6.3 SUBMITTALS

§ 6.3.1 The Bidder shall, as soon as practicable or as stipulated in the Bidding Documents, after notification of selection for the award of a Contract, furnish to the Owner through the Architect in writing:

- .1 a designation of the Work to be performed with the Bidder's own forces;
- .2 names of the manufacturers, products, and the suppliers of principal items or systems of materials and equipment proposed for the Work; and
- .3 names of persons or entities (including those who are to furnish materials or equipment fabricated to a special design) proposed for the principal portions of the Work.

§ 6.3.2 The Bidder will be required to establish to the satisfaction of the Architect and Owner the reliability and responsibility of the persons or entities proposed to furnish and perform the Work described in the Bidding Documents.

§ 6.3.3 Prior to the execution of the Contract, the Architect will notify the Bidder in writing if either the Owner or Architect, after due investigation, has reasonable objection to a person or entity proposed by the Bidder. If the Owner or Architect has reasonable objection to a proposed person or entity, the Bidder may, at the Bidder's option, (1) withdraw the Bid or (2) submit an acceptable substitute person or entity with an adjustment in the Base Bid or Alternate Bid to cover the difference in cost occasioned by such substitution. The Owner may accept the adjusted bid price or disqualify the Bidder. In the event of either withdrawal or disqualification, bid security will not be forfeited.

§ 6.3.4 Persons and entities proposed by the Bidder and to whom the Owner and Architect have made no reasonable objection must be used on the Work for which they were proposed and shall not be changed except with the written consent of the Owner and Architect.

ARTICLE 7 PERFORMANCE BOND AND PAYMENT BOND

§ 7.1 BOND REQUIREMENTS

§ 7.1.1 If stipulated in the Bidding Documents, the Bidder shall furnish bonds covering the faithful performance of the Contract and payment of all obligations arising thereunder. Bonds may be secured through the Bidder's usual sources.

§ 7.1.2 If the furnishing of such bonds is stipulated in the Bidding Documents, the cost shall be included in the Bid. If the furnishing of such bonds is required after receipt of bids and before execution of the Contract, the cost of such bonds shall be added to the Bid in determining the Contract Sum.

§ 7.1.3 If the Owner requires that bonds be secured from other than the Bidder's usual sources, changes in cost will be adjusted as provided in the Contract Documents.

§ 7.2 TIME OF DELIVERY AND FORM OF BONDS

§ 7.2.1 The Bidder shall deliver the required bonds to the Owner not later than three days following the date of execution of the Contract. If the Work is to be commenced prior thereto in response to a letter of intent, the Bidder shall, prior to commencement of the Work, submit evidence satisfactory to the Owner that such bonds will be furnished and delivered in accordance with this Section 7.2.1.

§ 7.2.2 Unless otherwise provided, the bonds shall be written on AIA Document A312, Performance Bond and Payment Bond. Both bonds shall be written in the amount of the Contract Sum.

§ 7.2.3 The bonds shall be dated on or after the date of the Contract.

§ 7.2.4 The Bidder shall require the attorney-in-fact who executes the required bonds on behalf of the surety to affix thereto a certified and current copy of the power of attorney.

ARTICLE 8 FORM OF AGREEMENT BETWEEN OWNER AND CONTRACTOR

Unless otherwise required in the Bidding Documents, the Agreement for the Work will be written on AIA Document A101, Standard Form of Agreement Between Owner and Contractor Where the Basis of Payment Is a Stipulated Sum.

OSE FORM 00201**STANDARD SUPPLEMENTAL INSTRUCTIONS TO BIDDERS****OWNER:** Spartanburg Community College**PROJECT NUMBER:** H59-6088-JM**PROJECT NAME:** Tyger River CBED Renovation**PROJECT LOCATION:** Spartanburg Community College, Tyger River Campus, Duncan, SC**PROCUREMENT OFFICER:** Gladden Smoke**1. STANDARD SUPPLEMENTAL INSTRUCTIONS TO BIDDERS**

1.1. These Standard Supplemental Instructions To Bidders amend or supplement Instructions To Bidders (AIA Document A701-1997) and other provisions of Bidding and Contract Documents as indicated below.

1.2. Compliance with these Standard Supplemental Instructions is required by the Office of State Engineer (OSE) for all State projects when competitive sealed bidding is used as the method of procurement.

1.3. All provisions of A701-1997, which are not so amended or supplemented, remain in full force and effect.

1.4. Bidders are cautioned to carefully examine the Bidding and Contract Documents for additional instructions or requirements.

2. MODIFICATIONS TO A701-1997

2.1. *Delete Section 1.1 and insert the following:*

1.1 Bidding Documents, collectively referred to as the **Invitation for Bids**, include the Bidding Requirements and the proposed Contract Documents. The Bidding Requirements consist of the Advertisement, Instructions to Bidders (A-701), Supplementary Instructions to Bidders, the bid form (SE-330), the Intent to Award Notice (SE-370), and other sample bidding and contract forms. The proposed Contract Documents consist of the form of Agreement between the Owner and Contractor, Conditions of the Contract (General, Supplementary and other Conditions), Drawings, Specifications, all Addenda issued prior to execution of the Contract, and other documents set forth in the Bidding Documents. Any reference in this document to the Agreement between the Owner and Contractor, AIA Document A101, or some abbreviated reference thereof, shall mean the AIA A101, 2007 Edition as modified by OSE Form 00501 – Standard Modification to Agreement Between Owner and Contractor. Any reference in this document to the General Conditions of the Contract for Construction, AIA Document A201, or some abbreviated reference thereof, shall mean the AIA A201, 2007 Edition as modified by OSE Form 00811 – Standard Supplementary Conditions.

2.2. *In Section 1.8, delete the words “and who meets the requirements set forth in the Bidding Documents”.*

2.3. *In Section 2.1, delete the word “making” and substitute the word “submitting.”*

2.4. *In Section 2.1.1:*

After the words “Bidding Documents,” delete the word “or” and substitute the word “and.”

Insert the following at the end of this section:

Bidders are expected to examine the Bidding Documents and Contract Documents thoroughly and should request an explanation of any ambiguities, discrepancies, errors, omissions, or conflicting statements. Failure to do so will be at the Bidder’s risk. Bidder assumes responsibility for any patent ambiguity that Bidder does not bring to the Owner’s attention prior to bid opening.

2.5. *In Section 2.1.3, insert the following after the term “Contract Documents” and before the period:*

and accepts full responsibility for any pre-bid existing conditions that would affect the Bid that could have been ascertained by a site visit. As provided in Regulation 19-445.2042(B), A bidder’s failure to attend an advertised pre-bid conference will not excuse its responsibility for estimating properly the difficulty and cost of successfully performing the work, or for proceeding to successfully perform the work without additional expense to the State.

OSE FORM 00201**STANDARD SUPPLEMENTAL INSTRUCTIONS TO BIDDERS**

2.6. *Insert the following Sections 2.2 through 2.6:*

2.2 CERTIFICATION OF INDEPENDENT PRICE DETERMINATION

GIVING FALSE, MISLEADING, OR INCOMPLETE INFORMATION ON THIS CERTIFICATION MAY RENDER YOU SUBJECT TO PROSECUTION UNDER SECTION 16-9-10 OF THE SOUTH CAROLINA CODE OF LAWS AND OTHER APPLICABLE LAWS.

(a) By submitting an bid, the bidder certifies that—

(1) The prices in this bid have been arrived at independently, without, for the purpose of restricting competition, any consultation, communication, or agreement with any other bidder or competitor relating to—

- (i) Those prices;
- (ii) The intention to submit an bid; or
- (iii) The methods or factors used to calculate the prices offered.

(2) The prices in this bid have not been and will not be knowingly disclosed by the bidder, directly or indirectly, to any other bidder or competitor before bid opening (in the case of a sealed bid solicitation) or contract award (in the case of a negotiated solicitation) unless otherwise required by law; and

(3) No attempt has been made or will be made by the bidder to induce any other concern to submit or not to submit an bid for the purpose of restricting competition.

(b) Each signature on the bid is considered to be a certification by the signatory that the signatory—

(1) Is the person in the bidder's organization responsible for determining the prices being offered in this bid, and that the signatory has not participated and will not participate in any action contrary to paragraphs (a)(1) through (a)(3) of this certification; or

(2)(i) Has been authorized, in writing, to act as agent for the bidder's principals in certifying that those principals have not participated, and will not participate in any action contrary to paragraphs (a)(1) through (a)(3) of this certification [As used in this subdivision (b)(2)(i), the term "principals" means the person(s) in the bidder's organization responsible for determining the prices offered in this bid];

(ii) As an authorized agent, does certify that the principals referenced in subdivision (b)(2)(i) of this certification have not participated, and will not participate, in any action contrary to paragraphs (a)(1) through (a)(3) of this certification; and

(iii) As an agent, has not personally participated, and will not participate, in any action contrary to paragraphs (a)(1) through (a)(3) of this certification.

(c) If the bidder deletes or modifies paragraph (a)(2) of this certification, the bidder must furnish with its offer a signed statement setting forth in detail the circumstances of the disclosure.

2.3 DRUG FREE WORKPLACE

By submitting a bid, the Bidder certifies that Bidder will maintain a drug free workplace in accordance with the requirements of Title 44, Chapter 107 of South Carolina Code of Laws, as amended.

2.4 CERTIFICATION REGARDING DEBARMENT AND OTHER RESPONSIBILITY MATTERS

(a) (1) By submitting an Bid, Bidder certifies, to the best of its knowledge and belief, that-

(i) Bidder and/or any of its Principals-

(A) Are not presently debarred, suspended, proposed for debarment, or declared ineligible for the award of contracts by any state or federal agency;

(B) Have not, within a three-year period preceding this bid, been convicted of or had a civil judgment rendered against them for: commission of fraud or a criminal offense in

OSE FORM 00201**STANDARD SUPPLEMENTAL INSTRUCTIONS TO BIDDERS**

connection with obtaining, attempting to obtain, or performing a public (Federal, state, or local) contract or subcontract; violation of Federal or state antitrust statutes relating to the submission of bids; or commission of embezzlement, theft, forgery, bribery, falsification or destruction of records, making false statements, tax evasion, or receiving stolen property; and

(C) Are not presently indicted for, or otherwise criminally or civilly charged by a governmental entity with, commission of any of the offenses enumerated in paragraph (a)(1)(i)(B) of this provision.

(ii) Bidder has not, within a three-year period preceding this bid, had one or more contracts terminated for default by any public (Federal, state, or local) entity.

(2) "Principals," for the purposes of this certification, means officers; directors; owners; partners; and, persons having primary management or supervisory responsibilities within a business entity (e.g., general manager; plant manager; head of a subsidiary, division, or business segment, and similar positions).

(b) Bidder shall provide immediate written notice to the Procurement Officer if, at any time prior to contract award, Bidder learns that its certification was erroneous when submitted or has become erroneous by reason of changed circumstances.

(c) If Bidder is unable to certify the representations stated in paragraphs (a)(1), Bid must submit a written explanation regarding its inability to make the certification. The certification will be considered in connection with a review of the Bidder's responsibility. Failure of the Bidder to furnish additional information as requested by the Procurement Officer may render the Bidder nonresponsible.

(d) Nothing contained in the foregoing shall be construed to require establishment of a system of records in order to render, in good faith, the certification required by paragraph (a) of this provision. The knowledge and information of an Bidder is not required to exceed that which is normally possessed by a prudent person in the ordinary course of business dealings.

(e) The certification in paragraph (a) of this provision is a material representation of fact upon which reliance was placed when making award. If it is later determined that the Bidder knowingly or in bad faith rendered an erroneous certification, in addition to other remedies available to the State, the Procurement Officer may terminate the contract resulting from this solicitation for default.

2.5 ETHICS CERTIFICATE

By submitting a bid, the bidder certifies that the bidder has and will comply with, and has not, and will not, induce a person to violate Title 8, Chapter 13 of the South Carolina Code of Laws, as amended (ethics act). The following statutes require special attention: Section 8-13-700, regarding use of official position for financial gain; Section 8-13-705, regarding gifts to influence action of public official; Section 8-13-720, regarding offering money for advice or assistance of public official; Sections 8-13-755 and 8-13-760, regarding restrictions on employment by former public official; Section 8-13-775, prohibiting public official with economic interests from acting on contracts; Section 8-13-790, regarding recovery of kickbacks; Section 8-13-1150, regarding statements to be filed by consultants; and Section 8-13-1342, regarding restrictions on contributions by contractor to candidate who participated in awarding of contract. The state may rescind any contract and recover all amounts expended as a result of any action taken in violation of this provision. If contractor participates, directly or indirectly, in the evaluation or award of public contracts, including without limitation, change orders or task orders regarding a public contract, contractor shall, if required by law to file such a statement, provide the statement required by Section 8-13-1150 to the procurement officer at the same time the law requires the statement to be filed.

2.6 RESTRICTIONS APPLICABLE TO BIDDERS & GIFTS

Violation of these restrictions may result in disqualification of your bid, suspension or debarment, and may constitute a violation of the state Ethics Act. (a) After issuance of the solicitation, ***bidder agrees not to discuss this procurement activity in any way with the Owner or its employees, agents or officials.*** All communications must be solely with the Procurement Officer. This restriction may be lifted by express written permission from the Procurement Officer. This restriction expires once a contract has been formed. (b) Unless otherwise approved in writing by the Procurement

OSE FORM 00201**STANDARD SUPPLEMENTAL INSTRUCTIONS TO BIDDERS**

Officer, *bidder agrees not to give anything to the Owner, any affiliated organizations, or the employees, agents or officials of either, prior to award.* (c) Bidder acknowledges that the policy of the State is that a governmental body should not accept or solicit a gift, directly or indirectly, from a donor if the governmental body has reason to believe the donor has or is seeking to obtain contractual or other business or financial relationships with the governmental body. Regulation 19-445.2165(C) broadly defines the term donor.

2.7. Delete Section 3.1.1 and substitute the following:

3.1.1 Bidders may obtain complete sets of the Bidding Documents from the issuing office designated in the Advertisement in the number and for the deposit sum, if any, stated therein. If so provided in the Advertisement, the deposit will be refunded to all plan holders who return the Bidding Documents in good condition within ten days after receipt of Bids. The cost of replacement of missing or damaged documents will be deducted from the deposit. A Bidder receiving a Contract award may retain the Bidding Documents and the Bidder's deposit will be refunded.

2.8. Delete the language of Section 3.1.2 and insert the word "Reserved."

2.9. In Section 3.1.4, delete the words "and Architect may make" and substitute the words "has made."

2.10. Insert the following Section 3.1.5

3.1.5 All persons obtaining Bidding Documents from the issuing office designated in the Advertisement shall provide that office with Bidder's contact information to include the Bidder's name, telephone number, mailing address, and email address.

2.11. In Section 3.2.2:

Delete the words "and Sub-bidders"

Delete the word "seven" and substitute the word "ten"

2.12. In Section 3.2.3:

In the first Sentence, insert the word "written" before the word "Addendum."

Insert the following at the end of the section:

As provided in Regulation 19-445.2042(B), nothing stated at the pre-bid conference shall change the Bidding Documents unless a change is made by written Addendum.

2.13. Insert the following at the end of Section 3.3.1:

Reference in the Bidding Documents to a designated material, product, thing, or service by specific brand or trade name followed by the words "or equal" and "or approved equal" shall be interpreted as establishing a standard of quality and shall not be construed as limiting competition.

2.14. Delete Section 3.3.2 and substitute the following:

3.3.2 No request to substitute materials, products, or equipment for materials, products, or equipment described in the Bidding Documents and no request for addition of a manufacturer or supplier to a list of approved manufacturers or suppliers in the Bidding Documents will be considered prior to receipt of Bids unless written request for approval has been received by the Architect at least ten days prior to the date for receipt of Bids established in the Invitation for Bids. Any subsequent extension of the date for receipt of Bids by addendum shall not extend the date for receipt of such requests unless the addendum so specifies. Such requests shall include the name of the material or equipment for which it is to be substituted and a complete description of the proposed substitution including drawings, performance and test data, and other information necessary for an evaluation. A statement setting forth changes in other materials, equipment or other portions of the Work, including changes in the work of other contracts that incorporation of the proposed substitution would require, shall be included. The burden of proof of the merit of the proposed substitution is upon the proposer. The Architect's decision of approval or disapproval of a proposed substitution shall be final.

2.15. Delete Section 3.4.3 and substitute the following:

3.4.3 Addenda will be issued no later than 120 hours prior to the time for receipt of Bids except an Addendum withdrawing the request for Bids or one which includes postponement of the date for receipt of Bids.

OSE FORM 00201**STANDARD SUPPLEMENTAL INSTRUCTIONS TO BIDDERS****2.16. Insert the following Sections 3.4.5 and 3.4.6:**

3.4.5 When the date for receipt of Bids is to be postponed and there is insufficient time to issue a written Addendum prior to the original Bid Date, Owner will notify prospective Bidders by telephone or other appropriate means with immediate follow up with a written Addendum. This Addendum will verify the postponement of the original Bid Date and establish a new Bid Date. The new Bid Date will be no earlier than the fifth (5th) calendar day after the date of issuance of the Addendum postponing the original Bid Date.

3.4.6. If an emergency or unanticipated event interrupts normal government processes so that bids cannot be received at the government office designated for receipt of bids by the exact time specified in the solicitation, the time specified for receipt of bids will be deemed to be extended to the same time of day specified in the solicitation on the first work day on which normal government processes resume. In lieu of an automatic extension, an Addendum may be issued to reschedule bid opening. If state offices are closed at the time a pre-bid or pre-proposal conference is scheduled, an Addendum will be issued to reschedule the conference. Useful information may be available at: http://www.scemd.org/scgovweb/weather_alert.html

2.17. In Section 4.1.1, delete the word “forms” and substitute the words “SE-330 Bid Form.”**2.18. Delete Section 4.1.2 and substitute the following:**

4.1.2 Any blanks on the bid form to be filled in by the Bidder shall be legibly executed in a non-erasable medium. Bids shall be signed in ink or other indelible media.

2.19. Delete Section 4.1.3 and substitute the following:

4.1.3 Sums shall be expressed in figures.

2.20. Insert the following at the end of Section 4.1.4:

Bidder shall not make stipulations or qualify his bid in any manner not permitted on the bid form. An incomplete Bid or information not requested that is written on or attached to the Bid Form that could be considered a qualification of the Bid, may be cause for rejection of the Bid.

2.21. Delete Section 4.1.5 and substitute the following:

4.1.5 All requested Alternates shall be bid. The failure of the bidder to indicate a price for an Alternate shall render the Bid non-responsive. Indicate the change to the Base Bid by entering the dollar amount and marking, as appropriate, the box for “ADD TO” or “DEDUCT FROM”. If no change in the Base Bid is required, enter “ZERO” or “No Change.” For add alternates to the base bid, Subcontractor(s) listed on page BF-2 of the Bid Form to perform Alternate Work shall be used for both Alternates and Base Bid Work if Alternates are accepted.

2.22. Delete Section 4.1.6 and substitute the following:

4.1.6 Pursuant to Title 11, Chapter 35, Section 3020(b)(i) of the South Carolina Code of Laws, as amended, Section 7 of the Bid Form sets forth a list of subcontractor specialties for which Bidder is required to list only the subcontractors Bidder will use to perform the work of each listed specialty. Bidder must follow the Instructions in the Bid Form for filling out this section of the Bid Form. Failure to properly fill out Section 7 may result in rejection of Bidder’s bid as non-responsive.

2.23. Delete Section 4.1.7 and substitute the following:

4.1.7 Each copy of the Bid shall state the legal name of the Bidder and the nature of legal form of the Bidder. Each copy shall be signed by the person or persons legally authorized to bind the Bidder to a contract. A Bid submitted by an agent shall have a current power of attorney attached certifying the agent's authority to bind the Bidder.

2.24. Delete Section 4.2.1 and substitute the following:

4.2.1 If required by the Invitation for Bids, each Bid shall be accompanied by a bid security in an amount of not less than five percent of the Base Bid. The bid security shall be a bid bond or a certified cashier’s check. The Bidder pledges to enter into a Contract with the Owner on the terms stated in the Bid and will, if required, furnish bonds covering the faithful performance of the Contract and payment of all obligations arising thereunder. Should the Bidder refuse to enter into such Contract or fail to furnish such bonds if required, the amount of the bid security shall be forfeited to the Owner as liquidated damages, not as a penalty.

OSE FORM 00201**STANDARD SUPPLEMENTAL INSTRUCTIONS TO BIDDERS****2.25. Delete Section 4.2.2 and substitute the following:**

4.2.2 If a surety bond is required, it shall be written on AIA Document A310, Bid Bond, and the attorney-in-fact who executes the bond on behalf of the surety shall affix to the bond a certified and current copy of the power of attorney. The bid bond shall:

- .1** Be issued by a surety company licensed to do business in South Carolina;
- .2** Be issued by a surety company having, at a minimum, a "Best Rating" of "A" as stated in the most current publication of "Best's Key Rating Guide, Property-Casualty", which company shows a financial strength rating of at least five (5) times the contract price.
- .3** Be enclosed in the bid envelope at the time of Bid Opening, either in paper copy or as an electronic bid bond authorization number provided on the Bid Form and issued by a firm or organization authorized by the surety to receive, authenticate and issue binding electronic bid bonds on behalf the surety.

2.26. Delete Section 4.2.3 and substitute the following:

4.2.3 By submitting a bid bond via an electronic bid bond authorization number on the Bid Form and signing the Bid Form, the Bidder certifies that an electronic bid bond has been executed by a Surety meeting the standards required by the Bidding Documents and the Bidder and Surety are firmly bound unto the State of South Carolina under the conditions provided in this Section 4.2.

2.27. Insert the following Section 4.2.4:

4.2.4 The Owner will have the right to retain the bid security of Bidders to whom an award is being considered until either (a) the Contract has been executed and performance and payment bonds, if required, have been furnished, or (b) the specified time has elapsed so that Bids may be withdrawn or (c) all Bids have been rejected.

2.28. Delete Section 4.3.1 and substitute the following:

4.3.1 All copies of the Bid, the bid security, if any, and any other documents required to be submitted with the Bid shall be enclosed in a sealed opaque envelope. The envelope shall, unless hand delivered by the Bidder, be addressed to the Owner's designated purchasing office as shown in the Invitation for Bids. The envelope shall be identified with the Project name, the Bidder's name and address and, if applicable, the designated portion of the Work for which the Bid is submitted. If the Bid is sent by mail or special delivery service (UPS, Federal Express, etc.), the envelope should be labeled "BID ENCLOSED" on the face thereof. Bidders hand delivering their Bids shall deliver Bids to the place of the Bid Opening as shown in the Invitation for Bids. Whether or not Bidders attend the Bid Opening, they shall give their Bids to the Owner's procurement officer or his/her designee as shown in the Invitation for Bids prior to the time of the Bid Opening.

2.29. Insert the following Section 4.3.6 and substitute the following:

4.3.5 The official time for receipt of Bids will be determined by reference to the clock designated by the Owner's procurement officer or his/her designee. The procurement officer conducting the Bid Opening will determine and announce that the deadline has arrived and no further Bids or bid modifications will be accepted. All Bids and bid modifications in the possession of the procurement officer at the time the announcement is completed will be timely, whether or not the bid envelope has been date/time stamped or otherwise marked by the procurement officer.

2.30. Delete Section 4.4.2 and substitute the following:

4.4.2 Prior to the time and date designated for receipt of Bids, a Bid submitted may be withdrawn in person or by written notice to the party receiving Bids at the place designated for receipt of Bids. Withdrawal by written notice shall be in writing over the signature of the Bidder.

2.31. In Section 5.1, delete everything following the caption "OPENING OF BIDS" and substitute the following:

5.1.1 Bids received on time will be publicly opened and will be read aloud. Owner will not read aloud Bids that Owner determines, at the time of opening, to be non-responsive. .

5.1.2 At bid opening, Owner will announce the date and location of the posting of the Notice of Intended Award.

5.1.3 Owner will send a copy of the final Bid Tabulation to all Bidders within ten (10) working days of the Bid Opening.

OSE FORM 00201**STANDARD SUPPLEMENTAL INSTRUCTIONS TO BIDDERS**

5.1.4 If Owner determines to award the Project, Owner will, after posting a Notice of Intended Award, send a copy of the Notice to all Bidders.

5.1.5 If only one Bid is received, Owner will open and consider the Bid.

2.32. *In Section 5.2, insert the section number “5.2.1” before the words of the “The Owner” at the beginning of the sentence.*

2.33. *Insert the following Sections 5.2.2 and 5.2.3:*

5.2.2 The reasons for which the Owner will reject Bids include, but are not limited to:

- .1** Failure by a Bidder to be represented at a Mandatory Pre-Bid Conference or site visit;
- .2** Failure to deliver the Bid on time;
- .3** Failure to comply with Bid Security requirements, except as expressly allowed by law;
- .4** Listing an invalid electronic Bid Bond authorization number on the bid form;
- .5** Failure to Bid an Alternate, except as expressly allowed by law;
- .6** Failure to list qualified Subcontractors as required by law;
- .7** Showing any material modification(s) or exception(s) qualifying the Bid;
- .8** Faxing a Bid directly to the Owner or their representative; or
- .9** Failure to include a properly executed Power-of-Attorney with the bid bond.

5.2.3 The Owner may reject a Bid as nonresponsive if the prices bid are materially unbalanced between line items or sub-line items. A bid is materially unbalanced when it is based on prices significantly less than cost for some work and prices which are significantly overstated in relation to cost for other work, and if there is a reasonable doubt that the bid will result in the lowest overall cost to the Owner even though it may be the low evaluated bid, or if it is so unbalanced as to be tantamount to allowing an advance payment.

2.34. *Delete Section 6.1 and substitute the following:*

6.1 CONTRACTOR'S RESPONSIBILITY

Owner will make a determination of Bidder's responsibility before awarding a contract. Bidder shall provide all information and documentation requested by the Owner to support the Owner's evaluation of responsibility. Failure of Bidder to provide requested information is cause for the Owner, at its option, to determine the Bidder to be non-responsible

2.35. *Delete the language of Section 6.2 and insert the word “Reserved.”*

2.36. *Delete the language of Sections 6.3.2, 6.3.3, and 6.3.4 and insert the word “Reserved” after each Section Number.*

2.37. *Insert the following Section 6.4*

6.4 CLARIFICATION

Pursuant to Section 11-35-1520(8), the Procurement Officer may elect to communicate with a Bidder after opening for the purpose of clarifying either the Bid or the requirements of the Invitation for Bids. Such communications may be conducted only with Bidders who have submitted a Bid which obviously conforms in all material aspects to the Invitation for Bids and only in accordance with Appendix D (Paragraph A(6)) to the Manual for Planning and Execution of State Permanent Improvement, Part II. Clarification of a Bid must be documented in writing and included with the Bid. Clarifications may not be used to revise a Bid or the Invitation for Bids. [Section 11-35-1520(8); R.19-445.2080]

2.38. *Delete Section 7.1.2 and substitute the following:*

7.1.2 The performance and payment bonds shall conform to the requirements of Section 11.4 of the General Conditions of the Contract. If the furnishing of such bonds is stipulated in the Bidding Documents, the cost shall be included in the Bid.

2.39. *Delete the language of Section 7.1.3 and insert the word “Reserved.”*

2.40. *In Section 7.2, insert the words “CONTRACT, CERTIFICATES OF INSURANCE” into the caption after the word “Delivery.”*

OSE FORM 00201**STANDARD SUPPLEMENTAL INSTRUCTIONS TO BIDDERS****2.41. Delete Section 7.2.1 and substitute the following:**

7.2.1 After expiration of the protest period, the Owner will tender a signed Contract for Construction to the Bidder and the Bidder shall return the fully executed Contract for Construction to the Owner within seven days thereafter. The Bidder shall deliver the required bonds and certificate of insurance to the Owner not later than three days following the date of execution of the Contract. Failure to deliver these documents as required shall entitle the Owner to consider the Bidder's failure as a refusal to enter into a contract in accordance with the terms and conditions of the Bidder's Bid and to make claim on the Bid Security for re-procurement cost.

2.42. Delete the language of Section 7.2.2 and insert the word "Reserved."**2.43. Delete the language of Article 8 and insert the following:**

Unless otherwise required in the Bidding Documents, the Agreement for the Work will be written on South Carolina Modified AIA Document A101, 2007, Standard Form of Agreement Between Owner and Contractor as modified by OSE Form 00501 – Standard Modification to Agreement Between Owner and Contractor.

2.44. Insert the following Article 9:**ARTICLE 9 MISCELLANEOUS****9.1 NONRESIDENT TAXPAYER REGISTRATION AFFIDAVIT INCOME TAX WITHHOLDING IMPORTANT TAX NOTICE - NONRESIDENTS ONLY**

Withholding Requirements for Payments to Nonresidents: Section 12-8-550 of the South Carolina Code of Laws requires persons hiring or contracting with a nonresident conducting a business or performing personal services of a temporary nature within South Carolina to withhold 2% of each payment made to the nonresident. The withholding requirement does not apply to (1) payments on purchase orders for tangible personal property when the payments are not accompanied by services to be performed in South Carolina, (2) nonresidents who are not conducting business in South Carolina, (3) nonresidents for contracts that do not exceed \$10,000 in a calendar year, or (4) payments to a nonresident who (a) registers with either the S.C. Department of Revenue or the S.C. Secretary of State and (b) submits a Nonresident Taxpayer Registration Affidavit - Income Tax Withholding, Form I-312 to the person letting the contract.

For information about other withholding requirements (e.g., employee withholding), contact the Withholding Section at the South Carolina Department of Revenue at 803-898-5383 or visit the Department's website at: www.sctax.org

This notice is for informational purposes only. This Owner does not administer and has no authority over tax issues. All registration questions should be directed to the License and Registration Section at 803-898-5872 or to the South Carolina Department of Revenue, Registration Unit, Columbia, S.C. 29214-0140. All withholding questions should be directed to the Withholding Section at 803-898- 5383.

PLEASE SEE THE "NONRESIDENT TAXPAYER REGISTRATION AFFIDAVIT INCOME TAX WITHHOLDING" FORM (FORM NUMBER I-312) LOCATED AT:

<http://www.sctax.org/Forms+and+Instructions/withholding/default.htm>.

9.2 CONTRACTOR LICENSING

Contractors and Subcontractors listed in Section 7 of the Bid Form who are required by the South Carolina Code of Laws to be licensed, must be licensed at the time of bidding.

9.3 SUBMITTING CONFIDENTIAL INFORMATION

For every document Bidder submits in response to or with regard to this solicitation or request, Bidder must separately mark with the word "CONFIDENTIAL" every page, or portion thereof, that Bidder contends contains information that is exempt from public disclosure because it is either (a) a trade secret as defined in Section 30-4-40(a)(1), or (b) privileged & confidential, as that phrase is used in Section 11-35-410. For every document Bidder submits in response to or with regard to this solicitation or request, Bidder must separately mark with the words "TRADE SECRET" every page, or portion thereof, that Bidder contends contains a trade secret as that term is defined by Section 39-8-20 of the Trade Secrets Act. For every document Bidder submits in response to or with regard to this solicitation or request, Bidder must separately mark with the word "PROTECTED" every page, or portion thereof, that Bidder contends is protected by Section 11-35-1810. All markings must be conspicuous; use color, bold, underlining, or some other method in order to conspicuously distinguish the mark from the other text. Do not mark your entire bid as confidential, trade secret, or protected! If your bid, or any part thereof, is improperly marked as confidential or trade

OSE FORM 00201**STANDARD SUPPLEMENTAL INSTRUCTIONS TO BIDDERS**

secret or protected, the State may, in its sole discretion, determine it nonresponsive. If only portions of a page are subject to some protection, do not mark the entire page. By submitting a response to this solicitation, Bidder (1) agrees to the public disclosure of every page of every document regarding this solicitation or request that was submitted at any time prior to entering into a contract (including, but not limited to, documents contained in a response, documents submitted to clarify a response, & documents submitted during negotiations), unless the page is conspicuously marked "TRADE SECRET" or "CONFIDENTIAL" or "PROTECTED", (2) agrees that any information not marked, as required by these bidding instructions, as a "Trade Secret" is not a trade secret as defined by the Trade Secrets Act, & (3) agrees that, notwithstanding any claims or markings otherwise, any prices, commissions, discounts, or other financial figures used to determine the award, as well as the final contract amount, are subject to public disclosure. In determining whether to release documents, the State will detrimentally rely on Bidders's marking of documents, as required by these bidding instructions, as being either "Confidential" or "Trade Secret" or "PROTECTED". By submitting a response, Bidder agrees to defend, indemnify & hold harmless the State of South Carolina, its officers & employees, from every claim, demand, loss, expense, cost, damage or injury, including attorney's fees, arising out of or resulting from the State withholding information that Bidder marked as "confidential" or "trade secret" or "PROTECTED".

9.4 POSTING OF INTENT TO AWARD

Notice of Intent to Award, SE-370, will be posted at the following location:

Room or Area of Posting: Campus Operations Lobby

Building Where Posted: Campus Operations Building

Address of Building: 136 Community College Drive, Spartanburg, SC 29303

WEB site address (if applicable): N/A

Posting date will be announced at bid opening. In addition to posting the notice, the Owner will promptly send all responsive bidders a copy of the notice of intent to award and the final bid tabulation

9.5 PROTEST OF SOLICITATION OR AWARD

Any prospective bidder, offeror, contractor, or subcontractor who is aggrieved in connection with the solicitation of a contract shall protest within fifteen days of the date of issuance of the applicable solicitation document at issue. Any actual bidder, offeror, contractor, or subcontractor who is aggrieved in connection with the intended award or award of a contract shall protest within ten days of the date notification of intent to award is posted in accordance with Title 11, Chapter 35, Section 4210 of the South Carolina Code of Laws, as amended. A protest shall be in writing, shall set forth the grounds of the protest and the relief requested with enough particularity to give notice of the issues to be decided, and must be received by the State Engineer within the time provided.

Any protest must be addressed to the CPO, Office of State Engineer, and submitted in writing:

(a) by email to protest-ose@mmo.sc.gov,

(b) by facsimile at 803-737-0639, or

(c) by post or delivery to 1201 Main Street, Suite 600, Columbia, SC 29201.

By submitting a protest to the foregoing email address, you (and any person acting on your behalf) consent to receive communications regarding your protest (and any related protests) at the e-mail address from which you sent your protest.

9.6 SOLICITATION INFORMATION FROM SOURCES OTHER THAN OFFICIAL SOURCE

South Carolina Business Opportunities (SCBO) is the official state government publication for State of South Carolina solicitations. Any information on State agency solicitations obtained from any other source is unofficial and any reliance placed on such information is at the bidder's sole risk and is without recourse under the South Carolina Consolidated Procurement Code.

9.7 BUILDER'S RISK INSURANCE

Bidder's are directed to Article 11.3 of the South Carolina Modified AIA Document A201, 2007 Edition, which, unless provided otherwise in the bid documents, requires the contractor to provide builder's risk insurance on the project.

OSE FORM 00201**STANDARD SUPPLEMENTAL INSTRUCTIONS TO BIDDERS****9.8 TAX CREDIT FOR SUBCONTRACTING WITH MINORITY FIRMS**

Pursuant to Section 12-6-3350, taxpayers, who utilize certified minority subcontractors, may take a tax credit equal to 4% of the payments they make to said subcontractors. The payments claimed must be based on work performed directly for a South Carolina state contract. The credit is limited to a maximum of fifty thousand dollars annually. The taxpayer is eligible to claim the credit for 10 consecutive taxable years beginning with the taxable year in which the first payment is made to the subcontractor that qualifies for the credit. After the above ten consecutive taxable years, the taxpayer is no longer eligible for the credit. The credit may be claimed on Form TC-2, "Minority Business Credit." A copy of the subcontractor's certificate from the Governor's Office of Small and Minority Business (OSMBA) is to be attached to the contractor's income tax return. Taxpayers must maintain evidence of work performed for a State contract by the minority subcontractor. Questions regarding the tax credit and how to file are to be referred to: SC Department of Revenue, Research and Review, Phone: (803) 898-5786, Fax: (803) 898-5888. The subcontractor must be certified as to the criteria of a "Minority Firm" by the Governor's Office of Small and Minority Business Assistance (OSMBA). Certificates are issued to subcontractors upon successful completion of the certification process. Questions regarding subcontractor certification are to be referred to: Governor's Office of Small and Minority Business Assistance, Phone: (803) 734-0657, Fax: (803) 734-2498. Reference: SC §11-35-5010 – Definition for Minority Subcontractor & SC §11-35-5230 (B) – Regulations for Negotiating with State Minority Firms.

§ 9.9 OTHER SPECIAL CONDITIONS OF THE WORK

IRAN DIVESTMENT ACT - CERTIFICATION (JAN 2015): (a) The Iran Divestment Act List is a list published by the Board pursuant to Section 11-57-310 that identifies persons engaged in investment activities in Iran. Currently, the list is available at the following URL: <http://procurement.sc.gov/PS/PS-iran-divestment.phtm>(.) Section 11-57-310 requires the government to provide a person ninety days written notice before he is included on the list. The following representation, which is required by Section 11-57-330(A), is a material inducement for the State to award a contract to you. (b) By signing your Offer, you certify that, as of the date you sign, you are not on the then-current version of the Iran Divestment Act List. (c) You must notify the Procurement Officer immediately if, at any time before posting of a final statement of award, you are added to the Iran Divestment Act List.

END OF DOCUMENT

Bid Bond

CONTRACTOR:
(Name, legal status and address)

« »« »
« »

SURETY:
(Name, legal status and principal place of business)

« »« »
« »

OWNER:
(Name, legal status and address)

« »« »
« Spartanburg Community College
Post Office Drawer 4386
Spartanburg, SC 29305

BOND AMOUNT: \$ « »

PROJECT:
(Name, location or address, and Project number, if any)

Tyger River CBED Renovation
«Spartanburg Community College
Duncan, SC

Project No. H59-6088-JM»
« »

The Contractor and Surety are bound to the Owner in the amount set forth above, for the payment of which the Contractor and Surety bind themselves, their heirs, executors, administrators, successors and assigns, jointly and severally, as provided herein. The conditions of this Bond are such that if the Owner accepts the bid of the Contractor within the time specified in the bid documents, or within such time period as may be agreed to by the Owner and Contractor, and the Contractor either (1) enters into a contract with the Owner in accordance with the terms of such bid, and gives such bond or bonds as may be specified in the bidding or Contract Documents, with a surety admitted in the jurisdiction of the Project and otherwise acceptable to the Owner, for the faithful performance of such Contract and for the prompt payment of labor and material furnished in the prosecution thereof; or (2) pays to the Owner the difference, not to exceed the amount of this Bond, between the amount specified in said bid and such larger amount for which the Owner may in good faith contract with another party to perform the work covered by said bid, then this obligation shall be null and void, otherwise to remain in full force and effect. The Surety hereby waives any notice of an agreement between the Owner and Contractor to extend the time in which the Owner may accept the bid. Waiver of notice by the Surety shall not apply to any extension exceeding sixty (60) days in the aggregate beyond the time for acceptance of bids specified in the bid documents, and the Owner and Contractor shall obtain the Surety's consent for an extension beyond sixty (60) days.

If this Bond is issued in connection with a subcontractor's bid to a Contractor, the term Contractor in this Bond shall be deemed to be Subcontractor and the term Owner shall be deemed to be Contractor.

When this Bond has been furnished to comply with a statutory or other legal requirement in the location of the Project, any provision in this Bond conflicting with said statutory or legal requirement shall be deemed deleted herefrom and provisions conforming to such



ADDITIONS AND DELETIONS:
The author of this document has added information needed for its completion. The author may also have revised the text of the original AIA standard form. An *Additions and Deletions Report* that notes added information as well as revisions to the standard form text is available from the author and should be reviewed.

This document has important legal consequences. Consultation with an attorney is encouraged with respect to its completion or modification.

Any singular reference to Contractor, Surety, Owner or other party shall be considered plural where applicable.

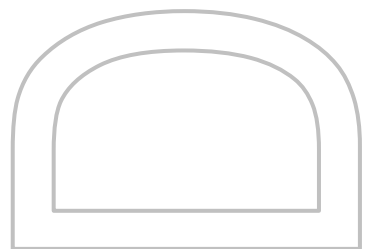
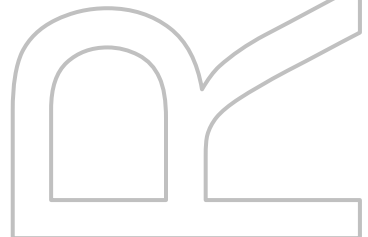

ELECTRONIC COPYING of any portion of this AIA[®] Document to another electronic file is prohibited and constitutes a violation of copyright laws as set forth in the footer of this document.

statutory or other legal requirement shall be deemed incorporated herein. When so furnished, the intent is that this Bond shall be construed as a statutory bond and not as a common law bond.

Signed and sealed this <> day of <>, <>

(Witness)

(Witness)

<>
(Contractor as Principal) (Seal)

<>
(Title)

<>
(Surety) (Seal)

<>
(Title)

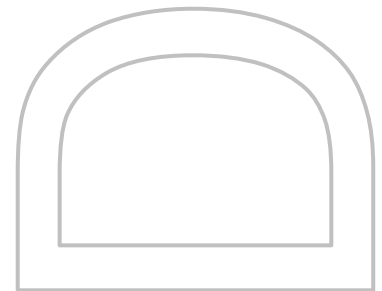
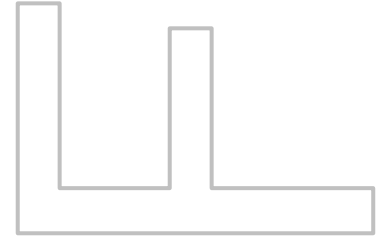

**SE-330 – LUMP SUM BID
BID FORM**

Bidders shall submit bids on only Bid Form SE-330.

BID SUBMITTED BY: _____
(Bidder's Name)

BID SUBMITTED TO: Spartanburg Community College
(Owner's Name)

FOR PROJECT: PROJECT NAME Tyger River CBED Renovation
PROJECT NUMBER H59-6088-JM

OFFER

§ 1. In response to the Invitation for Construction Bids and in compliance with the Instructions to Bidders for the above-named Project, the undersigned Bidder proposes and agrees, if this Bid is accepted, to enter into a Contract with the Owner on the terms included in the Bidding Documents, and to perform all Work as specified or indicated in the Bidding Documents, for the prices and within the time frames indicated in this Bid and in accordance with the other terms and conditions of the Bidding Documents.

§ 2. Pursuant to Section 11-32-3030(1) of the SC Code of Laws, as amended, Bidder has submitted Bid Security as follows in the amount and form required by the Bidding Documents:

- Bid Bond with Power of Attorney Electronic Bid Bond Cashier's Check

(Bidder check one)

§ 3. Bidder acknowledges the receipt of the following Addenda to the Bidding Documents and has incorporated the effects of said Addenda into this Bid:

ADDENDUM No: _____

§ 4. Bidder accepts all terms and conditions of the Invitation for Bids, including, without limitation, those dealing with the disposition of Bid Security. Bidder agrees that this Bid, including all Bid Alternates, if any, may not be revoked or withdrawn after the opening of bids, and shall remain open for acceptance for a period of 60 Days following the Bid Date, or for such longer period of time that Bidder may agree to in writing upon request of the Owner.

§ 5. Bidder herewith offers to provide all labor, materials, equipment, tools of trades and labor, accessories, appliances, warranties and guarantees, and to pay all royalties, fees, permits, licenses and applicable taxes necessary to complete the following items of construction work:

§ 6.1 BASE BID WORK *(as indicated in the Bidding Documents and generally described as follows):* Complete interior renovation of a portion of an existing campus building to include selective demolition, new interior partitions, doors, windows, finishes, ceilings, mechanical systems, lighting, power, data and fire protection systems. The U.S. Department of Commerce Economic Development Administration is providing partial funding for this project (EDA Investment No. 04-01-06828).

_____, which sum is hereafter called the Base Bid.

(Bidder - insert Base Bid Amount on line above)

**SE-330 – LUMP SUM BID
BID FORM**

§ 6.2 BID ALTERNATES - as indicated in the Bidding Documents and generally described as follows:

ALTERNATE # 1 (Brief Description): Provide lay-in metal ceiling panels (ACP-2) in floating ceiling clouds in Collaboration 119 and as specified in Section 095113 Acoustical Panel Ceilings.

ADD TO or **DEDUCT FROM BASE BID:** _____

(Bidder to Mark appropriate box to clearly indicate the price adjustment offered for each alternate)

ALTERNATE # 2 (Brief Description): Provide Metal ACM Wall Panels as shown on drawings and as specified in Section 098400 Metal Wall Systems.

ADD TO or **DEDUCT FROM BASE BID:** _____

(Bidder to Mark appropriate box to clearly indicate the price adjustment offered for each alternate)

ALTERNATE # 3 (Brief Description): Provide all work associated with upgrading Existing Toilets 133 & 134 as shown on drawings.

ADD TO or **DEDUCT FROM BASE BID:** _____

(Bidder to Mark appropriate box to clearly indicate the price adjustment offered for each alternate)

**SE-330 – LUMP SUM BID
 BID FORM**

§ 7. LISTING OF PROPOSED SUBCONTRACTORS PURSUANT TO SECTION 3020(b)(i), CHAPTER 35, TITLE 11 OF THE SOUTH CAROLINA CODE OF LAWS, AS AMENDED – (See *Instructions on the following page BF-2A*)

Bidder shall use the below-listed Subcontractors in the performance of the Subcontractor Specialty work listed:

SUBCONTRACTOR SPECIALTY By License Classification and/or Subclassification (Completed by Owner)	SUBCONTRACTOR'S PRIME CONTRACTOR'S NAME (Must be completed by Bidder) BASE BID	SUBCONTRACTOR'S PRIME CONTRACTOR'S SC LICENSE NUMBER
Air Conditioning - AC		
Heating - HT		
Plumbing - PB		
Electrical - EL		
ALTERNATE 1		
ALTERNATE 2		
ALTERNATE 3		

If a Bid Alternate is accepted, Subcontractors listed for the Bid Alternate shall be used for the work of both the Alternate and the Base Bid work.

INSTRUCTIONS FOR SUBCONTRACTOR LISTING

1. Section 7 of the Bid Form sets forth a list of subcontractor specialties for which bidder is required to identify by name the subcontractor(s) Bidder will use to perform the work of each listed specialty. Bidder must identify only the subcontractor(s) who will perform the work and no others.
2. For purposes of subcontractor listing, a Subcontractor is an entity who will perform work or render service to the prime contractor to or about the construction site. Material suppliers, manufacturers, and fabricators that will not perform physical work at the site of the project but will only supply materials or equipment to the bidder or proposed subcontractor(s) are not subcontractors and Bidder should not insert their names in the spaces provided on the bid form. Likewise, Bidder should not insert the names of sub-subcontractors in the spaces provided on the bid form but only the names of those entities with which bidder will contract directly.
3. Bidder must only insert the names of subcontractors who are qualified to perform the work of the listed specialties as specified in the Bidding Documents and South Carolina Licensing Laws.
4. If under the terms of the Bidding Documents, Bidder is qualified to perform the work of a specialty listed and Bidder does not intend to subcontract such work but to use Bidder's own employees to perform such work, the Bidder must insert its own name in the space provided for that specialty.
5. If Bidder intends to use multiple subcontractors to perform the work of a single specialty listing, Bidder must insert the name of each subcontractor Bidder will use, preferably separating the name of each by the word **“and”**. If Bidder intends to use both his own employees to perform a part of the work of a single specialty listing and to use one or more subcontractors to perform the remaining work for that specialty listing, bidder must insert his own name and the name of each subcontractor, preferably separating the name of each with the word **“and”**.
6. Bidder may not list subcontractors in the alternative nor in a form that may be reasonably construed at the time of bid opening as a listing in the alternative. A listing that requires subsequent explanation to determine whether or not it is a listing in the alternative is non-responsive. If bidder intends to use multiple entities to perform the work for a single specialty listing, bidder must clearly set forth on the bid form such intent. Bidder may accomplish this by simply inserting the word **“and”** between the name of each entity listed for that specialty. Owner will reject as non-responsive a listing that contains the names of multiple subcontractors separated by a blank space, the word **“or”**, a virgule (that is a /), or any separator that the Owner may reasonably interpret as a listing in the alternative.
7. If Bidder is awarded the contract, bidder must, except with the approval of the owner for good cause shown, use the listed entities to perform the work for which they are listed.
8. If bidder is awarded the contract, bidder will not be allowed to substitute another entity as subcontractor in place of a subcontractor listed in Section 7 of the Bid except for one or more of the reasons allowed by the SC Code of Laws.
9. Bidder's failure to insert a name for each listed specialty subcontractor will render the Bid non-responsive.

**SE-330 – LUMP SUM BID
BID FORM**

§ 8. LIST OF MANUFACTURERS, MATERIAL SUPPLIERS, AND SUBCONTRACTORS OTHER THAN SUBCONTRACTORS LISTED IN SECTION 7 ABOVE (FOR INFORMATION ONLY): Pursuant to instructions in the Invitation for Bids, if any, Bidder will provide to Owner upon the Owner's request and within 24 hours of such request, a listing of manufacturers, material suppliers, and subcontractors, other than those listed in Section 7 above, that Bidder intends to use on the project. Bidder acknowledges and agrees that this list is provided for purposes of determining responsibility and not pursuant to the subcontractor listing requirements of SC Code Ann § 11-35-3020(b)(i).

§ 9. TIME OF CONTRACT PERFORMANCE AND LIQUIDATED DAMAGES

a. **CONTRACT TIME:** Bidder agrees that the Date of Commencement of the Work shall be established in a Notice to Proceed to be issued by the Owner. Bidder agrees to substantially complete the Work within 135 calendar days from the Date of Commencement, subject to adjustments as provided in the Contract Documents.

b. **LIQUIDATED DAMAGES:** Bidder further agrees that from the compensation to be paid, the Owner shall retain as Liquidated Damages the sum of \$250.00 for each calendar day the actual construction time required to achieve Substantial Completion exceeds the specified or adjusted time for Substantial Completion as provided in the Contract Documents. This sum is intended by the parties as the predetermined measure of compensation for actual damages, not as a penalty for nonperformance.

§ 10. AGREEMENTS

- a. Bidder agrees that this bid is subject to the requirements of the law of the State of South Carolina.
- b. Bidder agrees that at any time prior to the issuance of the Notice to Proceed for this Project, this Project may be canceled for the convenience of, and without cost to, the State.
- c. Bidder agrees that neither the State of South Carolina nor any of its agencies, employees or agents shall be responsible for any bid preparation costs, or any costs or charges of any type, should all bids be rejected or the Project canceled for any reason prior to the issuance of the Notice to Proceed.

§ 11. ELECTRONIC BID BOND

By signing below, the Principal is affirming that the identified electronic bid bond has been executed and that the Principal and Surety are firmly bound unto the State of South Carolina under the terms and conditions of the AIA Document A310, Bid Bond, included in the Bidding Documents.

Electronic Bid Bond Number: _____

Signature and Title: _____

**SE-330 – LUMP SUM BID
BID FORM**

BIDDER'S TAXPAYER IDENTIFICATION

FEDERAL EMPLOYER'S IDENTIFICATION NUMBER: _____

OR

SOCIAL SECURITY NUMBER: _____

CONTRACTOR'S CLASSIFICATIONS AND SUBCLASSIFICATIONS WITH LIMITATIONS

Classification(s) & Limits: _____

Subclassification(s) & Limits: _____

SC Contractor's License Number(s): _____

BY SIGNING THIS BID, THE PERSON SIGNING REAFFIRMS ALL REPRESENTATIONS AND CERTIFICATIONS MADE BY BOTH THE PERSON SIGNING AND THE BIDDER, INCLUDING WITHOUT LIMITATION, THOSE APPEARING IN ARTICLE 2 OF THE INSTRUCTIONS TO BIDDER. THE INVITATION FOR BIDS, AS DEFINED IN THE INSTRUCTIONS TO BIDDERS, IS EXPRESSLY INCORPORATE BY REFERENCE.

SIGNATURE

BIDDER'S LEGAL NAME: _____

ADDRESS: _____

BY: _____
(Signature)

DATE: _____

TITLE: _____

TELEPHONE: _____

EMAIL: _____

DRAFT AIA® Document A101™ - 2007

Standard Form of Agreement Between Owner and Contractor where the basis of payment is a Stipulated Sum

AGREEMENT made as of the « » day of « » in the year « »
(In words, indicate day, month and year.)

BETWEEN the Owner:
(Name, legal status, address and other information)

« Spartanburg Community College »« »
«Post Office Drawer 4386 »
«Spartanburg, South Carolina 29305 »
« »

and the Contractor:
(Name, legal status, address and other information)

« »« »
« »
« »
« »

for the following Project:
(Name, location and detailed description)

«Tyger River CBED Renovation»
«Spartanburg Community College
Tyger River Campus
Duncan, South Carolina
»
«Renovation of a portion of the existing Tyger River facility for offices to serve the
CBED operations.»

The Architect:
(Name, legal status, address and other information)

« Craig Gaulden Davis, Inc.»« »
«19 Washington Park »
«Greenville, South Carolina 29601 »
« Telephone: 864-242-0761 »

The Owner and Contractor agree as follows.

ADDITIONS AND DELETIONS:
The author of this document has added information needed for its completion. The author may also have revised the text of the original AIA standard form. An *Additions and Deletions Report* that notes added information as well as revisions to the standard form text is available from the author and should be reviewed.

This document has important legal consequences. Consultation with an attorney is encouraged with respect to its completion or modification.

AIA Document A201™-2007, General Conditions of the Contract for Construction, is adopted in this document by reference. Do not use with other general conditions unless this document is modified.

ELECTRONIC COPYING of any portion of this AIA® Document to another electronic file is prohibited and constitutes a violation of copyright laws as set forth in the footer of this document.

TABLE OF ARTICLES

- 1 THE CONTRACT DOCUMENTS
- 2 THE WORK OF THIS CONTRACT
- 3 DATE OF COMMENCEMENT AND SUBSTANTIAL COMPLETION
- 4 CONTRACT SUM
- 5 PAYMENTS
- 6 DISPUTE RESOLUTION
- 7 TERMINATION OR SUSPENSION
- 8 MISCELLANEOUS PROVISIONS
- 9 ENUMERATION OF CONTRACT DOCUMENTS
- 10 INSURANCE AND BONDS

ARTICLE 1 THE CONTRACT DOCUMENTS

The Contract Documents consist of this Agreement, Conditions of the Contract (General, Supplementary and other Conditions), Drawings, Specifications, Addenda issued prior to execution of this Agreement, other documents listed in this Agreement and Modifications issued after execution of this Agreement, all of which form the Contract, and are as fully a part of the Contract as if attached to this Agreement or repeated herein. The Contract represents the entire and integrated agreement between the parties hereto and supersedes prior negotiations, representations or agreements, either written or oral. An enumeration of the Contract Documents, other than a Modification, appears in Article 9.

ARTICLE 2 THE WORK OF THIS CONTRACT

The Contractor shall fully execute the Work described in the Contract Documents, except as specifically indicated in the Contract Documents to be the responsibility of others.

ARTICLE 3 DATE OF COMMENCEMENT AND SUBSTANTIAL COMPLETION

§ 3.1 The date of commencement of the Work shall be the date of this Agreement unless a different date is stated below or provision is made for the date to be fixed in a notice to proceed issued by the Owner.

(Insert the date of commencement if it differs from the date of this Agreement or, if applicable, state that the date will be fixed in a notice to proceed.)

« »

If, prior to the commencement of the Work, the Owner requires time to file mortgages and other security interests, the Owner's time requirement shall be as follows:

« »

§ 3.2 The Contract Time shall be measured from the date of commencement.

§ 3.3 The Contractor shall achieve Substantial Completion of the entire Work not later than « » (« ») days from the date of commencement, or as follows:

(Insert number of calendar days. Alternatively, a calendar date may be used when coordinated with the date of commencement. If appropriate, insert requirements for earlier Substantial Completion of certain portions of the Work.)

« »

Portion of Work

Substantial Completion Date

, subject to adjustments of this Contract Time as provided in the Contract Documents.

(Insert provisions, if any, for liquidated damages relating to failure to achieve Substantial Completion on time or for bonus payments for early completion of the Work.)

« »

ARTICLE 4 CONTRACT SUM

§ 4.1 The Owner shall pay the Contractor the Contract Sum in current funds for the Contractor's performance of the Contract. The Contract Sum shall be « » (\$ « »), subject to additions and deductions as provided in the Contract Documents.

§ 4.2 The Contract Sum is based upon the following alternates, if any, which are described in the Contract Documents and are hereby accepted by the Owner:

(State the numbers or other identification of accepted alternates. If the bidding or proposal documents permit the Owner to accept other alternates subsequent to the execution of this Agreement, attach a schedule of such other alternates showing the amount for each and the date when that amount expires.)

« »

§ 4.3 Unit prices, if any:

(Identify and state the unit price; state quantity limitations, if any, to which the unit price will be applicable.)

Item	Units and Limitations	Price Per Unit (\$0.00)

§ 4.4 Allowances included in the Contract Sum, if any:

(Identify allowance and state exclusions, if any, from the allowance price.)

Item	Price

ARTICLE 5 PAYMENTS

§ 5.1 PROGRESS PAYMENTS

§ 5.1.1 Based upon Applications for Payment submitted to the Architect by the Contractor and Certificates for Payment issued by the Architect, the Owner shall make progress payments on account of the Contract Sum to the Contractor as provided below and elsewhere in the Contract Documents.

§ 5.1.2 The period covered by each Application for Payment shall be one calendar month ending on the last day of the month, or as follows:

« »

§ 5.1.3 Provided that an Application for Payment is received by the Architect not later than the « » day of a month, the Owner shall make payment of the certified amount to the Contractor not later than the « » day of the « » month. If an Application for Payment is received by the Architect after the application date fixed above, payment shall be made by the Owner not later than « » (« ») days after the Architect receives the Application for Payment. *(Federal, state or local laws may require payment within a certain period of time.)*

§ 5.1.4 Each Application for Payment shall be based on the most recent schedule of values submitted by the Contractor in accordance with the Contract Documents. The schedule of values shall allocate the entire Contract Sum among the various portions of the Work. The schedule of values shall be prepared in such form and supported by such data to substantiate its accuracy as the Architect may require. This schedule, unless objected to by the Architect, shall be used as a basis for reviewing the Contractor's Applications for Payment.

§ 5.1.5 Applications for Payment shall show the percentage of completion of each portion of the Work as of the end of the period covered by the Application for Payment.

§ 5.1.6 Subject to other provisions of the Contract Documents, the amount of each progress payment shall be computed as follows:

- .1 Take that portion of the Contract Sum properly allocable to completed Work as determined by multiplying the percentage completion of each portion of the Work by the share of the Contract Sum allocated to that portion of the Work in the schedule of values, less retainage of « » percent (« » %). Pending final determination of cost to the Owner of changes in the Work, amounts not in dispute shall be included as provided in Section 7.3.9 of AIA Document A201™–2007, General Conditions of the Contract for Construction;
- .2 Add that portion of the Contract Sum properly allocable to materials and equipment delivered and suitably stored at the site for subsequent incorporation in the completed construction (or, if approved in advance by the Owner, suitably stored off the site at a location agreed upon in writing), less retainage of « » percent (« » %);
- .3 Subtract the aggregate of previous payments made by the Owner; and
- .4 Subtract amounts, if any, for which the Architect has withheld or nullified a Certificate for Payment as provided in Section 9.5 of AIA Document A201–2007.

§ 5.1.7 The progress payment amount determined in accordance with Section 5.1.6 shall be further modified under the following circumstances:

- .1 Add, upon Substantial Completion of the Work, a sum sufficient to increase the total payments to the full amount of the Contract Sum, less such amounts as the Architect shall determine for incomplete Work, retainage applicable to such work and unsettled claims; and
(Section 9.8.5 of AIA Document A201–2007 requires release of applicable retainage upon Substantial Completion of Work with consent of surety, if any.)
- .2 Add, if final completion of the Work is thereafter materially delayed through no fault of the Contractor, any additional amounts payable in accordance with Section 9.10.3 of AIA Document A201–2007.

§ 5.1.8 Reduction or limitation of retainage, if any, shall be as follows:

(If it is intended, prior to Substantial Completion of the entire Work, to reduce or limit the retainage resulting from the percentages inserted in Sections 5.1.6.1 and 5.1.6.2 above, and this is not explained elsewhere in the Contract Documents, insert here provisions for such reduction or limitation.)

« »

§ 5.1.9 Except with the Owner's prior approval, the Contractor shall not make advance payments to suppliers for materials or equipment which have not been delivered and stored at the site.

§ 5.2 FINAL PAYMENT

§ 5.2.1 Final payment, constituting the entire unpaid balance of the Contract Sum, shall be made by the Owner to the Contractor when

- .1 the Contractor has fully performed the Contract except for the Contractor's responsibility to correct Work as provided in Section 12.2.2 of AIA Document A201–2007, and to satisfy other requirements, if any, which extend beyond final payment; and
- .2 a final Certificate for Payment has been issued by the Architect.

§ 5.2.2 The Owner's final payment to the Contractor shall be made no later than 30 days after the issuance of the Architect's final Certificate for Payment, or as follows:

« »

ARTICLE 6 DISPUTE RESOLUTION

§ 6.1 INITIAL DECISION MAKER

The Architect will serve as Initial Decision Maker pursuant to Section 15.2 of AIA Document A201–2007, unless the parties appoint below another individual, not a party to this Agreement, to serve as Initial Decision Maker. *(If the parties mutually agree, insert the name, address and other contact information of the Initial Decision Maker, if other than the Architect.)*

<< >>
<< >>
<< >>
<< >>

§ 6.2 BINDING DISPUTE RESOLUTION

For any Claim subject to, but not resolved by, mediation pursuant to Section 15.3 of AIA Document A201–2007, the method of binding dispute resolution shall be as follows: *(Check the appropriate box. If the Owner and Contractor do not select a method of binding dispute resolution below, or do not subsequently agree in writing to a binding dispute resolution method other than litigation, Claims will be resolved by litigation in a court of competent jurisdiction.)*

- Arbitration pursuant to Section 15.4 of AIA Document A201–2007
 - Litigation in a court of competent jurisdiction
 - Other *(Specify)*
- << >>

ARTICLE 7 TERMINATION OR SUSPENSION

§ 7.1 The Contract may be terminated by the Owner or the Contractor as provided in Article 14 of AIA Document A201–2007.

§ 7.2 The Work may be suspended by the Owner as provided in Article 14 of AIA Document A201–2007.

ARTICLE 8 MISCELLANEOUS PROVISIONS

§ 8.1 Where reference is made in this Agreement to a provision of AIA Document A201–2007 or another Contract Document, the reference refers to that provision as amended or supplemented by other provisions of the Contract Documents.

§ 8.2 Payments due and unpaid under the Contract shall bear interest from the date payment is due at the rate stated below, or in the absence thereof, at the legal rate prevailing from time to time at the place where the Project is located.

(Insert rate of interest agreed upon, if any.)

<< >> % << >>

§ 8.3 The Owner’s representative:
(Name, address and other information)

<< >>
<< >>
<< >>
<< >>
<< >>
<< >>

§ 8.4 The Contractor’s representative:
(Name, address and other information)

<< >>
<< >>
<< >>
<< >>
<< >>
<< >>

§ 8.5 Neither the Owner's nor the Contractor's representative shall be changed without ten days written notice to the other party.

§ 8.6 Other provisions:

<< >>

ARTICLE 9 ENUMERATION OF CONTRACT DOCUMENTS

§ 9.1 The Contract Documents, except for Modifications issued after execution of this Agreement, are enumerated in the sections below.

§ 9.1.1 The Agreement is this executed AIA Document A101-2007, Standard Form of Agreement Between Owner and Contractor.

§ 9.1.2 The General Conditions are AIA Document A201-2007, General Conditions of the Contract for Construction.

§ 9.1.3 The Supplementary and other Conditions of the Contract:

Document	Title	Date	Pages

§ 9.1.4 The Specifications:

(Either list the Specifications here or refer to an exhibit attached to this Agreement.)

<< >>

Section	Title	Date	Pages

§ 9.1.5 The Drawings:

(Either list the Drawings here or refer to an exhibit attached to this Agreement.)

<< >>

Number	Title	Date

§ 9.1.6 The Addenda, if any:

Number	Date	Pages

Portions of Addenda relating to bidding requirements are not part of the Contract Documents unless the bidding requirements are also enumerated in this Article 9.

§ 9.1.7 Additional documents, if any, forming part of the Contract Documents:

- .1 AIA Document E201™-2007, Digital Data Protocol Exhibit, if completed by the parties, or the following:

<< >>

- 2 Other documents, if any, listed below:
(List here any additional documents that are intended to form part of the Contract Documents. AIA Document A201–2007 provides that bidding requirements such as advertisement or invitation to bid, Instructions to Bidders, sample forms and the Contractor’s bid are not part of the Contract Documents unless enumerated in this Agreement. They should be listed here only if intended to be part of the Contract Documents.)

<< >>

ARTICLE 10 INSURANCE AND BONDS

The Contractor shall purchase and maintain insurance and provide bonds as set forth in Article 11 of AIA Document A201–2007.

(State bonding requirements, if any, and limits of liability for insurance required in Article 11 of AIA Document A201–2007.)

Type of insurance or bond	Limit of liability or bond amount (\$0.00)

This Agreement entered into as of the day and year first written above.

OWNER (Signature)

<< >><< >>

(Printed name and title)

CONTRACTOR (Signature)

<< >><< >>

(Printed name and title)

OSE FORM 00811

STANDARD SUPPLEMENTARY CONDITIONS

OWNER: Spartanburg Community College

PROJECT NUMBER: H59-6088-JM

PROJECT NAME: Tyger River CBED Renovation

1 GENERAL CONDITIONS

The *General Conditions of the Contract for Construction*, AIA Document A201, 2007 Edition, Articles 1 through 15 inclusive, is a part of this Contract and is incorporated as fully as if herein set forth. For brevity, AIA Document A201 is also referred to in the Contract Documents collectively as the "General Conditions."

2 STANDARD SUPPLEMENTARY CONDITIONS

2.1 The following supplements modify, delete and/or add to the General Conditions. Where any portion of the General Conditions is modified or any paragraph, Section or clause thereof is modified or deleted by these Supplementary Conditions, the unaltered provisions of the General Conditions shall remain in effect.

2.2 Unless otherwise stated, the terms used in these Standard Supplementary Conditions which are defined in the General Conditions have the meanings assigned to them in the General Conditions.

3 MODIFICATIONS TO A201-2007

3.1 *Insert the following at the end of Section 1.1.1:*

Any reference in this document to the Agreement between the Owner and Contractor, AIA Document A101, or some abbreviated reference thereof, shall mean the AIA A101, 2007 Edition as modified by OSE Form 00501 – Standard Modification to Agreement Between Owner and Contractor. Any reference in this document to the General Conditions of the Contract for Construction, AIA Document A201, or some abbreviated reference thereof, shall mean the AIA A201, 2007 Edition as modified by OSE Form 00811 – Standard Supplementary Conditions.

3.2 *Delete the language of Section 1.1.8 and substitute the word "Reserved."*

3.3 *Add the following Section 1.1.9:*

1.1.9 NOTICE TO PROCEED

Notice to Proceed is a document issued by the Owner to the Contractor, with a copy to the Architect, directing the Contractor to begin prosecution of the Work in accordance with the requirements of the Contract Documents. The Notice to Proceed shall fix the date on which the Contract Time will commence.

3.4 *Insert the following at the end of Section 1.2.1:*

In the event of patent ambiguities within or between parts of the Contract Documents, the contractor shall 1) provide the better quality or greater quantity of Work, or 2) comply with the more stringent requirement, either or both in accordance with the Architect's interpretation.

3.5 *Delete Section 1.5.1 and substitute the following:*

1.5.1 The Architect and the Architect's consultants shall be deemed the authors and owners of their respective Instruments of Service and will retain all common law, statutory and other reserved rights, including copyrights. The Contractor, Subcontractors, Sub-subcontractors, and material or equipment suppliers shall not own or claim a copyright in the Instruments of Service. Submittal or distribution to meet official regulatory requirements or for other purposes in connection with this Project is not to be construed as a violation of the Architect's or Architect's consultants' reserved rights.

OSE FORM 00811

STANDARD SUPPLEMENTARY CONDITIONS

3.6 *Delete Section 2.1.1 and substitute the following:*

2.1.1 The Owner is the person or entity identified as such in the Agreement and is referred to throughout the Contract Documents as if singular in number. The Owner shall designate in writing a representative who shall have express authority to bind the Owner with respect to all matters requiring the Owner's approval or authorization, except as provided in Section 7.1.2. Except as otherwise provided in Section 4.2.1, the Architect does not have such authority. The term "Owner" means the Owner or the Owner's Representative. [Reference § 8.2 of the Agreement.]

3.7 *Delete Section 2.1.2 and substitute the following:*

2.1.2 The Owner shall furnish to the Contractor within fifteen days after receipt of a written request, information necessary and relevant for the Contractor to post Notice of Project Commencement pursuant to Title 29, Chapter 5, Section 23 of the South Carolina Code of Laws, as amended..

3.8 *Delete Section 2.2.3 and substitute the following:*

2.2.3 The Owner shall furnish surveys describing physical characteristics, legal limitations and utility locations for the site of the Project, and a legal description of the site. Subject to the Contractor's obligations, including those in Section 3.2, the Contractor shall be entitled to rely on the accuracy of information furnished by the Owner pursuant to this Section but shall exercise proper precautions relating to the safe performance of the Work.

3.9 *Replace the period at the end of the last sentence of Section 2.2.4 with a semicolon and insert the following after the inserted semicolon:*

"however, the Owner does not warrant the accuracy of any such information requested by the Contractor that is not otherwise required of the Owner by the Contract Documents. Neither the Owner nor the Architect shall be required to conduct investigations or to furnish the Contractor with any information concerning subsurface characteristics or other conditions of the area where the Work is to be performed beyond that which is provide in the Contract Documents."

3.10 *Delete Section 2.2.5 and substitute the following:*

2.2.5 Unless otherwise provided in the Contract Documents, the Owner shall furnish to the Contractor with ten copies of the Contract Documents. The Contractor may make reproductions of the Contract Documents pursuant to Section 1.5.2. All copies of the drawings and specifications, except the Contractor's record set, shall be returned or suitably accounted for to the Owner, on request, upon completion of the Work.

3.11 *Add the following Sections 2.2.6 and 2.2.7:*

2.2.6 The Owner assumes no responsibility for any conclusions or interpretation made by the Contractor based on information made available by the Owner.

2.2.7 The Owner shall obtain, at its own cost, general building and specialty inspection services as required by the Contract Documents. The Contractor shall be responsible for payment of any charges imposed for reinspections.

3.12 *Delete Section 2.4 and substitute the following:*

2.4 If the Contractor defaults or neglects to carry out the Work in accordance with the Contract Documents and fails within a ten-day period after receipt of written notice from the Owner to commence and continue correction of such default or neglect, including but not limited to providing necessary resources, with diligence and promptness, the Owner may, without prejudice to other remedies the Owner may have, correct such deficiencies. In such case an appropriate Change Directive shall be issued deducting from payments then or thereafter due the Contractor the reasonable cost of correcting such deficiencies, including Owner's expenses and compensation for the Architect's additional services made necessary by such default, neglect or failure. If payments then or thereafter due the Contractor are not sufficient to cover such amounts, the Contractor shall pay the difference to the Owner.

OSE FORM 00811**STANDARD SUPPLEMENTARY CONDITIONS**

3.13 *Insert the following at the end of Section 3.2.1:*

The Contractor acknowledges that it has investigated and satisfied itself as to the general and local conditions which can affect the work or its cost, including but not limited to (1) conditions bearing upon transportation, disposal, handling, and storage of materials; (2) the availability of labor, water, electric power, and roads; (3) uncertainties of weather, river stages, tides, or similar physical conditions at the site; (4) the conformation and conditions of the ground; and (5) the character of equipment and facilities needed preliminary to and during work performance. The Contractor also acknowledges that it has satisfied itself as to the character, quality, and quantity of surface and subsurface materials or obstacles to be encountered insofar as this information is reasonably ascertainable from an inspection of the site, including all exploratory work done by the Owner, as well as from the drawings and specifications made a part of this contract. Any failure of the Contractor to take the actions described and acknowledged in this paragraph will not relieve the Contractor from responsibility for estimating properly the difficulty and cost of successfully performing the work, or for proceeding to successfully perform the work without additional expense to the Owner.

3.14 *In the third sentence of Section 3.2.4, insert the word “latent” before the word “errors.”***3.15** *In the last sentence of Section 3.3.1, insert the words “by the Owner in writing” after the word “instructed.”***3.16** *Delete the third sentence of Section 3.5 and substitute the following sentences:*

Work, materials, or equipment not conforming to these requirements shall be considered defective. Unless caused by the Contractor or a subcontractor at any tier, the Contractor’s warranty excludes remedy for damage or defect caused by abuse, alterations to the Work not executed by the Contractor, improper or insufficient maintenance, improper operation, or normal wear and tear and normal usage.

3.17 *Insert the following at the end of Section 3.6:*

The Contractor shall comply with the requirements of Title 12, Chapter 9 of the South Carolina Code of Laws, as amended, regarding withholding tax for nonresidents, employees, contractors and subcontractors.

3.18 *In Section 3.7.1, delete the words “the building permit as well as for other” and insert the following sentence at the end of this section:*

Pursuant to Title 10, Chapter 1, Section 180 of the South Carolina Code of Laws, as amended, no local general or specialty building permits are required for state buildings.

3.19 *Delete the last sentence of Section 3.7.5 and substitute the following:*

Adjustments in the Contract Sum and Contract Time arising from the existence of such remains or features may be made as provided in Article 7.3.3.

3.20 *Delete the last sentence of Section 3.8.2.3 and substitute the following:*

The amount of the Change Order shall reflect the difference between actual costs, as documented by invoices, and the allowances under Section 3.8.2.1.

3.21 *In Section 3.9.1, insert a comma after the word “superintendent” in the first sentence and insert the following after the inserted comma:*

acceptable to the Owner,

3.22 *Delete Section 3.9.2 and substitute the following:*

3.9.2 The Contractor, as soon as practicable after award of the Contract, shall furnish in writing to the Owner the name and qualifications of a proposed superintendent. The Owner may reply within 14 days to the Contractor in writing stating (1) whether the Owner has reasonable objection to the proposed superintendent or (2) that the

OSE FORM 00811**STANDARD SUPPLEMENTARY CONDITIONS**

Owner requires additional time to review. Failure of the Owner to reply within the 14-day period shall constitute notice of no reasonable objection.

3.23 *After the first sentence in Section 3.9.3, insert the following sentence:*

The Contractor shall notify the Owner, in writing, of any proposed change in the superintendent, including the reason therefore, prior to making such change.

3.24 *Delete Section 3.10.3 and substitute the following:*

3.10.3 Additional requirements, if any, for the constructions schedule are as follows:
(Check box if applicable to this Contract))

The construction schedule shall be in a detailed precedence-style critical path management (CPM) or primavera-type format satisfactory to the Owner and the Architect that shall also (1) provide a graphic representation of all activities and events that will occur during performance of the work; (2) identify each phase of construction and occupancy; and (3) set forth dates that are critical in ensuring the timely and orderly completion of the Work in accordance with the requirements of the Contract Documents (hereinafter referred to as "Milestone Dates"). Upon review and acceptance by the Owner and the Architect of the Milestone Dates, the construction schedule shall be deemed part of the Contract Documents and attached to the Agreement as Exhibit "A." If not accepted, the construction schedule shall be promptly revised by the Contractor in accordance with the recommendations of the Owner and the Architect and resubmitted for acceptance. The Contactor shall monitor the progress of the Work for conformance with the requirements of the construction schedule and shall promptly advise the Owner of any delays or potential delays. Whenever the approved construction schedule no longer reflects actual conditions and progress of the work or the Contract Time is modified in accordance with the terms of the Contract Documents, the Contractor shall update the accepted construction schedule to reflect such conditions. In the event any progress report indicates any delays, the Contractor shall propose an affirmative plan to correct the delay, including overtime and/or additional labor, if necessary. In no event shall any progress report constitute an adjustment in the Contract Time, any Milestone Date, or the Contract Sum unless any such adjustment is agreed to by the Owner and authorized pursuant to Change Order.

3.25 *Add the following Section 3.10.4:*

3.10.4 Owner's review and acceptance of Contractor's schedule is not conducted for the purpose of either determining its accuracy and completeness or approving the construction means, methods, techniques, sequences or procedures. The Owner's approval shall not relieve the Contractor of any obligations. Unless expressly addressed in a Modification, the Owner's approval of a schedule shall not change the Contract Time.

3.26 *Add the following Section 3.12.5.1:*

3.12.5.1 The fire sprinkler shop drawings shall be prepared by a licensed fire sprinkler contractor and shall accurately reflect actual conditions affecting the required layout of the fire sprinkler system. The fire sprinkler contractor shall certify the accuracy of his shop drawings prior to submitting them for review and approval. The fire sprinkler shop drawings shall be reviewed and approved by the Architect's engineer of record who, upon approving the sprinkler shop drawings will submit them to the State Fire Marshal or other authorities having jurisdiction for review and approval. The Architect's engineer of record will submit a copy of the State Fire Marshal's approval letter to the Contractor, Architect, and OSE. Unless authorized in writing by OSE, neither the Contractor nor subcontractor at any tier shall submit the fire sprinkler shop drawings directly to the State Fire Marshal or other authorities having jurisdiction for approval.

3.27 *In the fourth sentence of Section 3.12.10, after the comma following the words "licensed design professional," insert the following:*

who shall comply with reasonable requirements of the Owner regarding qualifications and insurance and

3.28 *In Section 3.13, insert the section number "3.13.1" before the before the opening words "The Contractors shall."*

OSE FORM 00811**STANDARD SUPPLEMENTARY CONDITIONS**

3.29 Add the following Sections 3.13.2 and 3.13.3:

3.13.2 Protection of construction materials and equipment stored at the Project site from weather, theft, vandalism, damage, and all other adversity is solely the responsibility of the Contractor. The Contractor shall perform the work in a manner that affords reasonable access, both vehicular and pedestrian, to the site of the Work and all adjacent areas. The Work shall be performed, to the fullest extent reasonably possible, in such a manner that public areas adjacent to the site of the Work shall be free from all debris, building materials, and equipment likely to cause hazardous conditions.

3.13.3 The Contractor and any entity for whom the Contractor is responsible shall not erect any sign on the Project site without the prior written consent of the Owner.

3.30 *In the first sentence of Section 3.18.1, after the parenthetical “...(other than the Work itself),...” and before the word “...but...”, insert the following:*

including loss of use resulting therefrom,

3.31 *Delete Section 4.1.1 and substitute the following:*

4.1.1 The Architect is that person or entity identified as the Architect in the Agreement and is referred to throughout the Contract Documents as if singular in number.

3.32 *Insert the following at the end of Section 4.2.1:*

Any reference in the Contract Documents to the Architect taking action or rendering a decision with a “reasonable time” is understood to mean no more than fourteen days, unless otherwise specified in the Contract Documents or otherwise agreed to by the parties.

3.33 *Delete the first sentence of Section 4.2.2 and substitute the following:*

The Architect will visit the site as necessary to fulfill its obligation to the Owner for inspection services, if any, and, at a minimum, to assure conformance with the Architect’s design as shown in the Contract Documents and to observe the progress and quality of the various components of the Contractor’s Work, and to determine if the Work observed is being performed in a manner indicating that the Work, when fully completed, will be in accordance with the Contract Documents.

3.34 *Delete the first sentence of Section 4.2.3 and substitute the following:*

On the basis of the site visits, the Architect will keep the Owner informed about the progress and quality of the portion of the Work completed, and report to the Owner (1) deviations from the Contract Documents and from the most recent construction schedule submitted by the Contractor, and (2) defects and deficiencies observed in the Work.

3.35 *In Section 4.2.5, after the words “evaluations of the” and before the word “Contractor’s,” insert the following:*

Work completed and correlated with the

3.36 *Delete the first sentence of Section 4.2.11 and substitute the following:*

4.2.11 The Architect will, in the first instance, interpret and decide matters concerning performance under, and requirements of, the Contract Documents on written request of either the Owner or Contractor. Upon receipt of such request, the Architect will promptly provide the non-requesting party with a copy of the request.

OSE FORM 00811

STANDARD SUPPLEMENTARY CONDITIONS

3.37 *Insert the following at the end of Section 4.2.12:*

If either party disputes the Architects interpretation or decision, that party may proceed as provided in Article 15. The Architect's interpretations and decisions may be, but need not be, accorded any deference in any review conducted pursuant to law or the Contract Documents.

3.38 *Delete Section 4.2.14 and substitute the following:*

The Architect will review and respond to requests for information about the Contract Documents so as to avoid delay to the construction of the Project. The Architect's response to such requests will be made in writing with reasonable promptness. If appropriate, the Architect will prepare and issue supplemental Drawings and Specifications in response to the requests for information. Any response to a request for information must be consistent with the intent of, and reasonably inferable from, the Contract Documents and will be in writing or in the form of drawings. Unless issued pursuant to a Modification, supplemental Drawings or Specifications will not involve an adjustment to the Contract Sum or Contract Time.

3.39 *Delete Section 5.2.1 and substitute the following:*

5.2.1 Unless otherwise stated in the Contract Documents or the bidding requirements, the Contractor, within fourteen days after posting of the Notice of Intent to Award the Contract, shall furnish in writing to the Owner through the Architect the names of persons or entities (excluding Listed Subcontractors but including those who are to furnish materials or equipment fabricated to a special design) proposed for each principal portion of the Work. The Owner may reply within 14 days to the Contractor in writing stating (1) whether the Owner has reasonable objection to any such proposed person or entity. Failure of the Owner to reply within the 14 day period shall constitute notice of no reasonable objection.

3.40 *Delete Section 5.2.2 and substitute the following:*

5.2.2 The Contractor shall not contract with a proposed person or entity to whom the Owner has made reasonable and timely objection. The Owner shall not direct the Contractor to contract with any specific individual or entity for supplies or services unless such supplies and services are necessary for completion of the Work and the specified individual or entity is the only source of such supply or services.

3.41 *In the first sentence of Section 5.2.3, delete the words "...or Architect..." in the two places they appear.*

3.42 *Delete the words "...or Architect..." in the in the first sentence of Section 5.2.4 and insert the following sentence at the end of Section 5.2.4:*

The Contractor's request for substitution must be made to the Owner in writing accompanied by supporting information.

3.43 *Add the following Section 5.2.5:*

5.2.5 A Subcontractor identified in the Contractor's Bid in response the specialty subcontractor listing requirements of Section 7 of the Bid Form (SE-330) may only be substituted in accordance with and as permitted by the provisions of Title 11, Chapter 35, Section 3021 of the South Carolina Code of Laws, as amended. A proposed substitute for a Listed Subcontractor shall be subject to the Owner's approval as set forth is Section 5.2.3.

3.44 *In Section 5.3, delete everything following the heading "SUBCONTRACTUAL RELATIONS" and insert the following Sections 5.3.1, 5.3.2, 5.3.3, and 5.3.4:*

5.3.1 By appropriate written agreement, the Contractor shall require each Subcontractor, to the extent of the Work to be performed by the Subcontractor, to be bound to the Contractor by terms of the Contract Documents, and to assume toward the Contractor all the obligations and responsibilities, including the responsibility for safety of the Subcontractor's Work, which the Contractor, by these Documents, assumes toward the Owner and Architect. Each subcontract agreement shall preserve and protect the rights of the Owner and Architect under the Contract Documents with respect to the Work to be performed by the Subcontractor so that subcontracting thereof will not

OSE FORM 00811**STANDARD SUPPLEMENTARY CONDITIONS**

prejudice such rights, and shall allow to the Subcontractor, unless specifically provided otherwise herein or in the subcontract agreement, the benefit of all rights, remedies and redress against the Contractor that the Contractor, by the Contract Documents, has against the Owner. Where appropriate, the Contractor shall require each Subcontractor to enter into similar agreements with Sub-subcontractors. The Contractor shall make available to each proposed Subcontractor, prior to the execution of the subcontract agreement, copies of the Contract Documents to which the Subcontractor will be bound, and, upon written request of the Subcontractor, identify to the Subcontractor terms and conditions of the proposed subcontract agreement that may be at variance with the Contract Documents. Subcontractors will similarly make copies of applicable portions of such documents available to their respective proposed Sub-subcontractors.

§ 5.3.2 Without limitation on the generality of Section 5.3.1, each Subcontract agreement and each Sub-subcontract agreement shall include, and shall be deemed to include, the following Sections of these General Conditions: 3.2, 3.5, 3.18, 5.3, 5.4, 6.2.2, 7.3.3, 7.5, 7.6, 13.1, 13.12, 14.3, 14.4, and 15.1.6.

§ 5.3.3 Each Subcontract Agreement and each Sub-subcontract agreement shall exclude, and shall be deemed to exclude, Sections 13.2.1 and 13.6 and all of Article 15, except Section 15.1.6, of these General Conditions. In the place of these excluded sections of the General Conditions, each Subcontract Agreement and each Sub-subcontract may include Sections 13.2.1 and 13.6 and all of Article 15, except Section 15.1.6, of AIA Document A201-2007, Conditions of the Contract, as originally issued by the American Institute of Architects.

§ 5.3.4 The Contractor shall assure the Owner that all agreements between the Contractor and its Subcontractor incorporate the provisions of Subparagraph 5.3.1 as necessary to preserve and protect the rights of the Owner and the Architect under the Contract Documents with respect to the work to be performed by Subcontractors so that the subcontracting thereof will not prejudice such rights. The Contractor's assurance shall be in the form of an affidavit or in such other form as the Owner may approve. Upon request, the Contractor shall provide the Owner or Architect with copies of any or all subcontracts or purchase orders.

3.45 *Delete the last sentence of Section 5.4.1.*

3.46 *Add the following Sections 5.4.4, 5.4.5 and 5.4.6:*

§ 5.4.4 Each subcontract shall specifically provide that the Owner shall only be responsible to the subcontractor for those obligations of the Contractor that accrue subsequent to the Owner's exercise of any rights under this conditional assignment.

§ 5.4.5 Each subcontract shall specifically provide that the Subcontractor agrees to perform portions of the Work assigned to the Owner in accordance with the Contract Documents.

§ 5.4.6 Nothing in this Section 5.4 shall act to reduce or discharge the Contractor's payment bond surety's obligations to claimants for claims arising prior to the Owner's exercise of any rights under this conditional assignment.

3.47 *Delete the language of Section 6.1.4 and substitute the word "Reserved."*

3.48 *Insert the following at the end of Section 7.1.2:*

If the amount of a Modification exceeds the limits of the Owner's Construction Change Order Certification (reference Section 9.1.7.2 of the Agreement), then the Owner's agreement is not effective, and Work may not proceed, until approved in writing by the Office of State Engineer.

3.49 *Delete Section 7.2.1 and substitute the following:*

7.2.1 A Change Order is a written instrument prepared by the Architect (using State Form SE-480 "Construction Change Order") and signed by the Owner, Contractor and Architect stating their agreement upon all of the following:

- .1 The change in the Work;

OSE FORM 00811**STANDARD SUPPLEMENTARY CONDITIONS**

- .2 The amount of the adjustment, if any, in the Contract Sum; and
- .3 The extent of the adjustment, if any, in the Contract Time.

3.50 *Add the following Sections 7.2.2, 7.2.3, 7.2.4, and 7.2.5:*

7.2.2 If a Change Order provides for an adjustment to the Contract Sum, the adjustment must be calculated in accordance with Section 7.3.3.

7.2.3 At the Owner's request, the Contractor shall prepare a proposal to perform the work of a proposed Change Order setting forth the amount of the proposed adjustment, if any, in the Contract Sum; and the extent of the proposed adjustment, if any, in the Contract Time. Any proposed adjustment in the Contract sum shall be prepared in accordance with Section 7.2.2. The Owner's request shall include any revisions to the Drawings or Specifications necessary to define any changes in the Work. Within fifteen days of receiving the request, the Contractor shall submit the proposal to the Owner and Architect along with all documentation required by Section 7.6.

7.2.4 If the Contractor requests a Change Order, the request shall set forth the proposed change in the Work and shall be prepared in accordance with Section 7.2.3. If the Contractor requests a change to the Work that involves a revision to either the Drawings or Specifications, the Contractor shall reimburse the Owner for any expenditures associated with the Architects' review of the proposed revisions, except to the extent the revisions are accepted by execution of a Change Order.

7.2.5 Agreement on any Change Order shall constitute a final settlement of all matters relating to the change in the Work that is the subject of the Change Order, including, but not limited to, any adjustments to the Contract Sum or the Contract Time.

3.51 *Delete 7.3.3 and substitute the following:*

7.3.3 PRICE ADJUSTMENTS

§ **7.3.3.1** If any Modification, including a Construction Change Directive, provides for an adjustment to the Contract Sum, the adjustment shall be based on whichever of the following methods is the most valid approximation of the actual cost to the contractor, with overhead and profit as allowed by Section 7.5:

- .1 Mutual acceptance of a lump sum;
- .2 Unit prices stated in the Contract Documents, except as provided in Section 7.3.4, or subsequently agreed upon;
- .3 Cost attributable to the events or situations under applicable clauses with adjustment of profits or fee, all as specified in the contract, or subsequently agreed upon by the parties, or by some other method as the parties may agree; or
- .4 As provided in Section 7.3.7.

§ **7.3.3.2** Consistent with Section 7.6, costs must be properly itemized and supported by substantiating data sufficient to permit evaluation before commencement of the pertinent performance or as soon after that as practicable. All costs incurred by the Contractor must be justifiably compared with prevailing industry standards. Except as provided in Section 7.5, all adjustments to the Contract Price shall be limited to job specific costs and shall not include indirect costs, overhead, home office overhead, or profit.

3.52 *Delete Section 7.3.7 and substitute the following:*

7.3.7 If the Contractor does not respond promptly or disagrees with the method for adjustment in the Contract Sum, the Architect shall make an initial determination, consistent with Section 7.3.3, of the method and the adjustment on the basis of reasonable expenditures and savings of those performing the Work attributable to the change, including, in case of an increase in the Contract Sum, an amount for overhead and profit as set forth in Section 7.5. In such case, and also under Section 7.3.3.1.3, the Contractor shall keep and present, in such form as the Architect may prescribe, an itemized accounting together with appropriate supporting data. Unless otherwise provided in the Contract Documents, costs for the purposes of this Section 7.3.7 shall be limited to the following:

OSE FORM 00811**STANDARD SUPPLEMENTARY CONDITIONS**

- .1 Costs of labor, including social security, old age and unemployment insurance, fringe benefits required by agreement or custom, and workers' compensation insurance;
- .2 Costs of materials, supplies and equipment, including cost of transportation, whether incorporated or consumed;
- .3 Rental costs of machinery and equipment, exclusive of hand tools, whether rented from the Contractor or others; and
- .4 Costs of premiums for all bonds and insurance, permit fees, and sales, use or similar taxes related to the Work.

3.53 *Delete Section 7.3.8 and substitute the following:*

7.3.8 Using the percentages stated in Section 7.5, any adjustment to the Contract Sum for deleted work shall include any overhead and profit attributable to the cost for the deleted Work.

3.54 *Add the following Sections 7.5 and 7.6:***7.5 AGREED OVERHEAD AND PROFIT RATES**

7.5.1 For any adjustment to the Contract Sum for which overhead and profit may be recovered, other than those made pursuant to Unit Prices stated in the Contract Documents, the Contractor agrees to charge and accept, as full payment for overhead and profit, the following percentages of costs attributable to the change in the Work. The percentages cited below shall be considered to include all indirect costs including, but not limited to: field and office managers, supervisors and assistants, incidental job burdens, small tools, and general overhead allocations. The allowable percentages for overhead and profit are as follows:

- .1 To the Contractor for work performed by the Contractor's own forces, 17% of the Contractor's actual costs.
- .2 To each Subcontractor for work performed by the Subcontractor's own forces, 17% of the subcontractor's actual costs.
- .3 To the Contractor for work performed by a subcontractor, 10% of the subcontractor's actual costs (not including the subcontractor's overhead and profit).

7.6 PRICING DATA AND AUDIT**§ 7.6.1 Cost or Pricing Data.**

Upon request of the Owner or Architect, Contractor shall submit cost or pricing data prior to execution of a Modification which exceeds \$500,000. Contractor shall certify that, to the best of its knowledge and belief, the cost or pricing data submitted is accurate, complete, and current as of a mutually determined specified date prior to the date of pricing the Modification. Contractor's price, including profit, shall be adjusted to exclude any significant sums by which such price was increased because Contractor furnished cost or pricing data that was inaccurate, incomplete, or not current as of the date specified by the parties. Notwithstanding Subparagraph 9.10.4, such adjustments may be made after final payment to the Contractor.

§ 7.6.2 Cost or pricing data means all facts that, as of the date specified by the parties, prudent buyers and sellers would reasonably expect to affect price negotiations significantly. Cost or pricing data are factual, not judgmental; and are verifiable. While they do not indicate the accuracy of the prospective contractor's judgment about estimated future costs or projections, they do include the data forming the basis for that judgment. Cost or pricing data are more than historical accounting data; they are all the facts that can be reasonably expected to contribute to the soundness of estimates of future costs and to the validity of determinations of costs already incurred.

§ 7.6.3 Records Retention.

As used in Section 7.6, the term "records" means any books or records that relate to cost or pricing data that Contractor is required to submit pursuant to Section 7.6.1. Contractor shall maintain records for three years from the date of final payment, or longer if requested by the chief procurement officer. The Owner may audit Contractor's records at reasonable times and places.

OSE FORM 00811**STANDARD SUPPLEMENTARY CONDITIONS**

3.55 Delete Section 8.2.2 and substitute the following:

8.2.2 The Contractor shall not knowingly commence operations on the site or elsewhere prior to the effective date of surety bonds and insurance required by Article 11 to be furnished by the Contractor and Owner. The date of commencement of the Work shall not be changed by the effective date of such surety bonds or insurance.

3.56 Delete Section 8.3.1 and substitute the following:

8.3.1 If the Contractor is delayed at any time in the commencement or progress of the Work by an act or neglect of the Owner or Architect, or of an employee of either, or of a separate contractor employed by the Owner; or by changes ordered in the Work; or by labor disputes, fire, unusual delay in deliveries, unavoidable casualties or other causes beyond the control of the Contractor and any subcontractor at any tier; or by delay authorized by the Owner pending dispute resolution; or by other causes that the Architect determines may justify delay, then to the extent such delay will prevent the Contractor from achieving Substantial Completion within the Contract Time and provided the delay (1) is not caused by the fault or negligence of the Contractor or a subcontractor at any tier and (2) is not due to unusual delay in the delivery of supplies, machinery, equipment, or services when such supplies, machinery, equipment, or services were obtainable from other sources in sufficient time for the Contractor to meet the required delivery, the Contract Time shall be extended by Change Order for such reasonable time as the Architect may determine.

3.57 Insert the following at the end of Section 9.1:

All changes to the Contract Sum shall be adjusted in accordance with Section 7.3.3.

3.58 Delete Section 9.2 and substitute the following:

9.2 SCHEDULE OF VALUES

9.2.1 The Contractor shall submit to the Architect, within ten days of full execution of the Agreement, a schedule of values allocating the entire Contract Sum to the various portions of the Work and prepared in such form and supported by such data to substantiate its accuracy as the Architect may require. This schedule, unless objected to by the Architect, shall be used as a basis for reviewing the Contractor's Applications for Payment. As requested by the Architect, the Contractor and each Subcontractor shall prepare a trade payment breakdown for the Work for which each is responsible, such breakdown being submitted on a uniform standardized format approved by the Architect and Owner. The breakdown shall be divided in detail, using convenient units, sufficient to accurately determine the value of completed Work during the course of the Project. The Contractor shall update the schedule of values as required by either the Architect or Owner as necessary to reflect:

- .1** the description of Work (listing labor and material separately);
- .2** the total value;
- .3** the percent and value of the Work completed to date;
- .4** the percent and value of previous amounts billed; and
- .5** the current percent completed and amount billed.

9.2.2 Any schedule of values or trade breakdown that fails to include sufficient detail, is unbalanced, or exhibits "front-loading" of the value of the Work shall be rejected. If a schedule of values or trade breakdown is used as the basis for payment and later determined to be inaccurate, sufficient funds shall be withheld from future Applications for Payment to ensure an adequate reserve (exclusive of normal retainage) to complete the Work.

3.59 Delete Section 9.3.1 and substitute the following:

Monthly, the Contractor shall submit to the Architect an itemized Application for Payment prepared in accordance with the schedule of values, if required under Section 9.2., for completed portions of the Work. Such application shall be notarized, if required, and supported by such data substantiating the Contractor's right to payment as the Owner or Architect may require (such as copies of requisitions from Subcontractors and material suppliers) and shall reflect retainage and any other adjustments provided in Section 5 of the Agreement. If required by the Owner or Architect, the Application for Payment shall be accompanied by a current construction schedule.

OSE FORM 00811**STANDARD SUPPLEMENTARY CONDITIONS**

3.60 In Section 9.3.2, add the following words to the end of the second sentence:

provided such materials or equipment will be subsequently incorporated in the Work

Insert the following at the end of Section 9.3.2:

The Contractor shall 1) protect such materials from diversion, vandalism, theft, destruction, and damage, 2) mark such materials specifically for use on the Project, and 3) segregate such materials from other materials at the storage facility. The Architect and the Owner shall have the right to make inspections of the storage areas at any time.

3.61 *In Section 9.4.2, in the first sentence, after the words “Work has progressed to the point indicated,” insert the following:*

in both the Application for Payment and, if required to be submitted by the Contractor, the accompanying current construction schedule

In the last sentence, delete the third item starting with “(3) reviewed copies” and ending with “Contractor’s right to payment,”

3.62 *In Section 9.5.1, in the first sentence, delete the word “may” after the opening words “The Architect” and substitute the word “shall.”*

In Section 9.5.1, insert the following sentence after the first sentence:

The Architect shall withhold a Certificate of Payment if the Application for Payment is not accompanied by the current construction schedule required by Section 3.10.1.

3.63 *In Section 9.6.2, delete the word “The...” at the beginning of the first sentence and substitute the following:*

Pursuant to Chapter 6 of Title 29 of the South Carolina Code of Laws, as amended, the

3.64 *Delete Section 9.7 and substitute following:*

9.7 FAILURE OF PAYMENT

If the Architect does not issue a Certificate for Payment to the Owner, through no fault of the Contractor, within seven days after receipt of the Contractor’s Application for Payment, or if the Owner does not pay the Contractor within seven days after the time established in the Contract Documents the amount certified by the Architect or awarded by a final dispute resolution order, then the Contractor may, upon seven additional days’ written notice to the Owner and Architect, stop the Work until payment of the amount owing has been received. The Contract Time shall be extended appropriately and the Contract Sum shall be increased, in accordance with the provisions of Section 7.3.3, by the amount of the Contractor’s reasonable costs of shut-down, delay and start-up, plus interest as provided for in the Contract Documents.

3.65 *Insert the following words at the end of the sentence in Section 9.8.1:*

and when all required occupancy permits, if any, have been issued and copies of same have been delivered to the Owner.

3.66 *In Section 9.8.2, insert the word “written” after the word “comprehensive” and before the word “list.”*

3.67 *Delete Section 9.8.3 and substitute the following:*

9.8.3.1 Upon receipt of the Contractor’s list, the Architect, with the Owner and any other person the Architect or the Owner choose, will make an inspection on a date and at a time mutually agreeable to the Architect, Owner, and Contractor, to determine whether the Work or designated portion thereof is substantially complete. The Contractor shall furnish access for the inspection and testing as provided in this Contract. The inspection shall include a

OSE FORM 00811**STANDARD SUPPLEMENTARY CONDITIONS**

demonstration by the Contractor that all equipment, systems and operable components of the Work function properly and in accordance with the Contract Documents. If the Architect's inspection discloses any item, whether or not included on the Contractor's list, which is not sufficiently complete in accordance with the Contract Documents so that the Owner can occupy or utilize the Work or designated portion thereof for its intended use, the Contractor shall, before issuance of the Certificate of Substantial Completion, complete or correct such item upon notification by the Architect. In such case, the Contractor shall then submit a request for another inspection by the Architect to determine Substantial Completion. If more than one Substantial Completion inspection is required, the Contractor shall reimburse the Owner for all costs of reinspections or, at the Owner's option, the costs may be deducted from payments due to the Contractor.

9.8.3.2 If the Architect and Owner concur in the Contractor's assessment that the Work or a portion of the Work is safe to occupy, the Owner and Contractor may arrange for a Certificate of Occupancy Inspection by OSE. The Owner, Architect, and Contractor shall be present at OSE's inspection. Upon verifying that the Work or a portion of the Work is substantially complete and safe to occupy, OSE will issue, as appropriate, a Full or Partial Certificate of Occupancy.

3.68 *In the second sentence of Section 9.8.5, delete the words "and consent of surety, if any."*

3.69 *In the first sentence of Section 9.9.1, delete the words "Section 11.3.1.5" and substitute the words "Section 11.3.1.3."*

3.70 *Delete Section 9.10.1 and substitute the following:*

9.10.1 Unless the parties agree otherwise in the Certificate of Substantial Completion, the Contractor shall achieve Final Completion no later than thirty days after Substantial Completion. Upon receipt of the Contractor's written notice that the Work is ready for final inspection and acceptance and upon receipt of a final Application for Payment, the Architect, with the Owner and any other person the Architect or the Owner choose, will make an inspection on a date and at a time mutually agreeable to the Architect, Owner, and Contractor, and, when the Architect finds the Work acceptable under the Contract Documents and the Contract fully performed, the Architect will promptly issue a final Certificate for Payment stating that to the best of the Architect's knowledge, information and belief, and on the basis of the Architect's on-site visits and inspections, the Work has been completed in accordance with terms and conditions of the Contract Documents and that the entire balance found to be due the Contractor and noted in the final Certificate is due and payable. The Architect's final Certificate for Payment will constitute a further representation that conditions listed in Section 9.10.2 as precedent to the Contractor's being entitled to final payment have been fulfilled. If more than one Final Completion inspection is required, the Contractor shall reimburse the Owner for all costs of reinspections or, at the Owner's option, the costs may be deducted from payments due to the Contractor. If the Contractor does not achieve final completion within thirty days after Substantial Completion or the timeframe agreed to by the parties in the Certificate of Substantial Completion, whichever is greater, the Contractor shall be responsible for any additional Architectural fees resulting from the delay.

3.71 *Delete the first sentence of Section 9.10.2 and substitute the following:*

Neither final payment nor any remaining retained percentage shall become due until the Contractor submits to the Architect (1) an affidavit that payrolls, bills for materials and equipment, and other indebtedness connected with the Work for which the Owner or the Owner's property might be responsible or encumbered (less amounts withheld by Owner) have been paid or otherwise satisfied, (2) a certificate evidencing that insurance required by the Contract Documents to remain in force after final payment is currently in effect and will not be canceled or allowed to expire until at least 30 days' prior written notice has been given to the Owner, (3) a written statement that the Contractor knows of no substantial reason that the insurance will not be renewable to cover the period required by the Contract Documents, (4) consent of surety, if any, to final payment (5), if required by the Owner, other data establishing payment or satisfaction of obligations, such as receipts, releases and waivers of liens, claims, security interests or encumbrances arising out of the Contract, to the extent and in such form as may be designated by the Owner, (6) required Training Manuals, (7) equipment Operations and Maintenance Manuals, (8) any certificates of testing, inspection or approval required by the Contract Documents and not previously provided (9) all warranties and guarantees required under or pursuant to the Contract Documents, and (10) one copy of the Documents required by Section 3.11.

OSE FORM 00811**STANDARD SUPPLEMENTARY CONDITIONS**

3.72 Delete the first sentence of Section 9.10.3 and substitute the following:

If, after Substantial Completion of the Work, final completion thereof is delayed 60 days through no fault of the Contractor or by issuance of Change Orders affecting final completion, and the Architect so confirms, the Owner shall, upon application by the Contractor and certification by the Architect, and without terminating the Contract, make payment of the balance due for that portion of the Work fully completed and accepted.

3.73 Delete Section 9.10.5 and substitute the following:

§9.10.5 Acceptance of final payment by the Contractor, a Subcontractor or material supplier shall constitute a waiver of claims by that payee except those specific claims in stated amounts that have been previously made in writing and identified by that payee as unsettled at the time of final Application for Payment.

3.74 Add the following Section 9.10.6:

9.10.6 If OSE has not previously issued a Certificate of Occupancy for the entire Project, the Parties shall arrange for a representative of OSE to participate in the Final Completion Inspection. Representatives of the State Fire Marshal's Office and other authorities having jurisdiction may be present at the Final Completion Inspection or otherwise inspect the completed Work and advise the Owner whether the Work meets their respective requirements for the Project.

3.75 Delete Section 10.3.1 and substitute the following:

10.3.1 If the Contractor encounters a hazardous material or substance which was not discoverable as provided in Section 3.2.1 and not required by the Contract Documents, and if reasonable precautions will be inadequate to prevent foreseeable bodily injury or death to persons or serious loss to real or personal property resulting from such material or substance encountered on the site by the Contractor, the Contractor shall, upon recognizing the condition, immediately stop Work in the affected area and report the condition to the Owner and Architect in writing. Hazardous materials or substances are those hazardous, toxic, or radioactive materials or substances subject to regulations by applicable governmental authorities having jurisdiction, such as, but not limited to, the S.C. Department of Health and Environmental Control, the U.S. Environmental Protection Agency, and the U.S. Nuclear Regulatory Commission.

3.76 Insert the following at the end of Section 10.3.2:

In the absence of agreement, the Architect will make an interim determination regarding any delay or impact on the Contractor's additional costs. The Architect's interim determination of cost shall adjust the Contract Sum on the same basis as a Change Order, subject to the right of either party to disagree and assert a Claim in accordance with Article 15. Any adjustment in the Contract Sum shall be determined in accordance with Section 7.3.3.

3.77 Delete Section 10.3.3 and substitute the following:

10.3.3 The Work in the affected area shall be resumed immediately following the occurrence of any one of the following events: (a) the Owner causes remedial work to be performed that results in the absence of hazardous materials or substances; (b) the Owner and the Contractor, by written agreement, decide to resume performance of the Work; or (c) the Work may safely and lawfully proceed, as determined by an appropriate governmental authority or as evidenced by a written report to both the Owner and the Contractor, which is prepared by an environmental engineer reasonably satisfactory to both the Owner and the Contractor.

3.78 In Section 10.3.5, delete the word "The" at the beginning of the sentence and substitute the following:

In addition to its obligations under Section 3.18, the

3.79 Delete the language of Section 10.3.6 and substitute the word "Reserved."

OSE FORM 00811**STANDARD SUPPLEMENTARY CONDITIONS**

endorsements must be received directly from either the Contractor's insurance agent or the insurance company. An additional certificate evidencing continuation of liability coverage, including coverage for completed operations, naming the Owner as an additional insured for claims made under the Contractor's completed operations, and otherwise meeting the above requirements, shall be submitted with the final Application for Payment as required by Section 9.10.2 and thereafter upon renewal or replacement of such coverage until the expiration of the time required by Section 11.1.2. Information concerning reduction of coverage on account of revised limits or claims paid under the General Aggregate, or both, shall be furnished by the Contractor with reasonable promptness.

3.83 *Delete Section 11.1.4 and substitute the following:*

11.1.4 A failure by the Owner either (i) to demand a certificate of insurance or written endorsement required by Section 11.1, or (ii) to reject a certificate or endorsement on the grounds that it fails to comply with Section 11.1 shall not be considered a waiver of Contractor's obligations to obtain the required insurance.

3.84 *In Section 11.3.1, delete the first sentence and substitute the following:*

Unless otherwise provided in the Contract Documents, the Contractor shall purchase and maintain, in a company or companies lawfully authorized to do business in the jurisdiction in which the Project is located, property insurance written on a builder's risk "all-risk" or equivalent policy form in the amount of the initial Contract Sum, plus value of subsequent Contract Modifications and cost of materials supplied or installed by others, comprising total value for the entire Project at the site on a replacement cost basis.

3.85 *Delete the language of Section 11.3.1.2 and substitute the word "Reserved."*

3.86 *Delete the language of Section 11.3.1.3 and substitute the word "Reserved."*

3.87 *Delete Section 11.3.2 and substitute the following:*

11.3.2 BOILER AND MACHINERY INSURANCE

The Contractor shall purchase and maintain boiler and machinery insurance required by the Contract Documents or by law, which shall specifically cover such insured objects during installation and until final acceptance by the Owner; this insurance shall include interests of the Owner, Contractor, Subcontractors and Sub-subcontractors in the Work, and the Owner and Contractor shall both be named insureds.

3.88 *Delete Section 11.3.3 and substitute the following:*

11.3.3 LOSS OF USE INSURANCE

The Owner, at the Owner's option, may purchase and maintain such insurance as will insure the Owner against loss of use of the Owner's property due to fire or other hazards, however caused. To the extent any losses are covered and paid for by such insurance, the Owner waives all rights of action against the Contractor for loss of use of the Owner's property, including consequential losses due to fire or other hazards however caused.

3.89 *Delete Section 11.3.4 and substitute the following:*

11.3.4 If the Owner requests in writing that insurance for risks other than those described herein or other special causes of loss be included in the property insurance policy, the Contractor shall, if possible, include such insurance, and the cost thereof shall be charged to the Owner by appropriate Change Order.

3.90 *Delete the language of Section 11.3.5 and substitute the word "Reserved."*

3.91 *Delete Section 11.3.6 and substitute the following:*

11.3.6 Before an exposure to loss may occur, the Contractor shall file with the Owner a copy of each policy that includes insurance coverages required by this Section 11.3. Each policy shall contain all generally applicable conditions, definitions, exclusions and endorsements related to this Project. Each policy shall contain a provision that the policy will not be canceled or allowed to expire, and that its limits will not be reduced, until at least 30 days' prior written notice has been given to the Owner.

OSE FORM 00811**STANDARD SUPPLEMENTARY CONDITIONS**

3.92 Delete the first sentence of Section 11.3.7 and substitute the following:

The Owner and Contractor waive all rights against (1) each other and any of their subcontractors, sub-subcontractors, agents and employees, each of the other, and (2) the Architect, Architect's consultants, separate contractors described in Article 6, if any, and any of their subcontractors, sub-subcontractors, agents and employees, for damages caused by fire or other causes of loss to the extent the property insurance provided by the Contractor pursuant to this Section 11.3 covers and pays for the damage, except such rights as they have to proceeds of such insurance held by the Contractor as fiduciary.

3.93 Delete the first sentence of Section 11.3.8 and substitute the following:

A loss insured under the Contractor's property insurance shall be adjusted by the Contractor as fiduciary and made payable to the Contractor as fiduciary for the insureds, as their interests may appear, subject to requirements of any applicable mortgagee clause and of Section 11.3.10.

3.94 Delete Section 11.3.9 and substitute the following:

11.3.9 If required in writing by a party in interest, the Contractor as fiduciary shall, upon occurrence of an insured loss, give bond for proper performance of the Contractor's duties. The cost of required bonds shall be charged against proceeds received as fiduciary. The Contractor shall deposit in a separate account proceeds so received, which the Contractor shall distribute in accordance with such agreement as the parties in interest may reach. If after such loss no other special agreement is made and unless the Owner terminates the Contract for convenience, replacement of damaged property shall be performed by the Contractor.

3.95 Delete Section 11.3.10 and substitute the following:

11.3.10 The Contractor as fiduciary shall have power to adjust and settle a loss with insurers unless one of the parties in interest shall object in writing within five days after occurrence of loss to the Contractor's exercise of this power; if such objection is made, the dispute shall be resolved in the manner provided in the contract between the parties in dispute as the method of binding dispute resolution. The Contractor as fiduciary shall make settlement with insurers or, in the case of a dispute over distribution of insurance proceeds, in accordance with a final order or determination issued by the appropriate authority having jurisdiction over the dispute..

3.96 Delete Section 11.4.1 and substitute the following:

11.4.1 Before commencing any services hereunder, the Contractor shall provide the Owner with Performance and Payment Bonds, each in an amount not less than the Contract Price set forth in Article 4 of the Agreement. The Surety shall have, at a minimum, a "Best Rating" of "A" as stated in the most current publication of "Best's Key Rating Guide, Property-Casualty". In addition, the Surety shall have a minimum "Best Financial Strength Category" of "Class V", and in no case less than five (5) times the contract amount. The Performance Bond shall be written on Form SE-355, "Performance Bond" and the Payment Bond shall written on Form SE-357, "Labor and Material Payment Bond", and both shall be made payable to the Owner.

3.97 Delete Section 11.4.2 and substitute the following:

11.4.2 The Performance and Labor and Material Payment Bonds shall:

- .1** be issued by a surety company licensed to do business in South Carolina;
- .2** be accompanied by a current power of attorney and certified by the attorney-in-fact who executes the bond on the behalf of the surety company; and
- .3** remain in effect for a period not less than one (1) year following the date of Substantial Completion or the time required to resolve any items of incomplete Work and the payment of any disputed amounts, whichever time period is longer.

OSE FORM 00811**STANDARD SUPPLEMENTARY CONDITIONS**

3.98 *Add the following Sections 11.4.3 and 11.4.4:*

11.4.3 Any bonds required by this Contract shall meet the requirements of the South Carolina Code of Laws and Regulations, as amended.

11.4.4 Upon the request of any person or entity appearing to be a potential beneficiary of bonds covering payment of obligations arising under the Contract, the Contractor shall promptly furnish a copy of the bonds or shall authorize a copy to be furnished.

3.99 *Delete Section 12.1.1 and substitute the following:*

12.1.1 If a portion of the Work is covered contrary to the requirements specifically expressed in the Contract Documents, including inspections of work-in-progress required by all authorities having jurisdiction over the Project, it must, upon demand of the Architect or authority having jurisdiction, be uncovered for observation and be replaced at the Contractor's expense without change in the Contract Time.

3.100 *In Section 12.2.2.1, delete the words "and to make a claim for breach of warranty" at the end of the third sentence.*

3.101 *In Section 12.2.2.3, add the following to the end of the sentence:*

unless otherwise provided in the Contract Documents.

3.102 *Insert the following at the end of Section 12.2.4:*

If, prior to the date of Substantial Completion, the Contractor, a Subcontractor, or anyone for whom either is responsible, uses or damages any portion of the Work, including, without limitation, mechanical, electrical, plumbing, and other building systems, machinery, equipment, or other mechanical device, the Contractor shall cause such item to be restored to "like new" condition at no expense to the Owner.

3.103 *Delete Section 13.1 and substitute the following:*

13.1 GOVERNING LAW

The Contract, any dispute, claim, or controversy relating to the Contract, and all the rights and obligations of the parties shall, in all respects, be interpreted, construed, enforced and governed by and under the laws of the State of South Carolina, except its choice of law rules.

3.104 *Delete Section 13.2, including its Sub-Sections 13.2.1 and 13.2.2, and substitute the following:*

13.2 SUCCESSORS AND ASSIGNS

The Owner and Contractor respectively bind themselves, their partners, successors, assigns and legal representatives to covenants, agreements and obligations contained in the Contract Documents. Neither party to the Contract shall assign the Contract as a whole, or in part, without written consent of the other and then only in accordance with and as permitted by Regulation 19-445.2180 of the South Carolina Code of Regulations, as amended. If either party attempts to make such an assignment without such consent, that party shall nevertheless remain legally responsible for all obligations under the Contract.

3.105 *Delete Section 13.3 and substitute the following:*

13.3 WRITTEN NOTICE

Unless otherwise permitted herein, all notices contemplated by the Contract Documents shall be in writing and shall be deemed given:

- .1** upon actual delivery, if delivery is by hand;
- .2** upon receipt by the transmitting party of confirmation or reply, if delivery is by electronic mail, facsimile, telex or telegram;
- .3** upon receipt, if delivery is by the United States mail.

OSE FORM 00811**STANDARD SUPPLEMENTARY CONDITIONS**

Notice to Contractor shall be to the address provided in Section 8.3.2 of the Agreement. Notice to Owner shall be to the address provided in Section 8.2.2 of the Agreement. Either party may designate a different address for notice by giving notice in accordance with this paragraph.

3.106 *In Section 13.4.1, insert the following at the beginning of the sentence:*

Unless expressly provided otherwise,

3.107 *Add the following Section 13.4.3:*

13.4.3 Notwithstanding Section 9.10.4, the rights and obligations which, by their nature, would continue beyond the termination, cancellation, rejection, or expiration of this contract shall survive such termination, cancellation, rejection, or expiration, including, but not limited to, the rights and obligations created by the following clauses:

1.5 Ownership and Use of Drawings, Specifications and Other Instruments of Service;

3.5 Warranty

3.17 Royalties, Patents and Copyrights

3.18 Indemnification

7.6 Cost or Pricing Data

11.1 Contractor's Liability Insurance

11.4 Performance and Payment Bond

15.1.6 Claims for Listed Damages

15.1.7 Waiver of Claims Against the Architect

15.6 Dispute Resolution

15.4 Service of Process

3.108 *Delete Section 13.6 and substitute the following:*

13.6 INTEREST

Payments due to the Contractor and unpaid under the Contract Documents shall bear interest only if and to the extent allowed by Title 29, Chapter 6, Article 1 of the South Carolina Code of Laws. Amounts due to the Owner shall bear interest at the rate of one percent a month or a pro rata fraction thereof on the unpaid balance as may be due.

3.109 *Delete the language of Section 13.7 and substitute the word "Reserved."*

3.110 *Add the following Sections 13.8 through 13.16:*

13.8 PROCUREMENT OF MATERIALS BY OWNER

The Contractor accepts assignment of all purchase orders and other agreements for procurement of materials and equipment by the Owner that are identified as part of the Contract Documents. The Contractor shall, upon delivery, be responsible for the storage, protection, proper installation, and preservation of such Owner purchased items, if any, as if the Contractor were the original purchaser. The Contract Sum includes, without limitation, all costs and expenses in connection with delivery, storage, insurance, installation, and testing of items covered in any assigned purchase orders or agreements. Unless the Contract Documents specifically provide otherwise, all Contractor warranty of workmanship and correction of the Work obligations under the Contract Documents shall apply to the Contractor's installation of and modifications to any Owner purchased items,.

13.9 INTERPRETATION OF BUILDING CODES

As required by Title 10, Chapter 1, Section 180 of the South Carolina Code of Laws, as amended, OSE shall determine the enforcement and interpretation of all building codes and referenced standards on state buildings. The Contractor shall refer any questions, comments, or directives from local officials to the Owner and OSE for resolution.

OSE FORM 00811**STANDARD SUPPLEMENTARY CONDITIONS****13.10 MINORITY BUSINESS ENTERPRISES**

Contractor shall notify Owner of each Minority Business Enterprise (MBE) providing labor, materials, equipment, or supplies to the Project under a contract with the Contractor. Contractor's notification shall be via the first monthly status report submitted to the Owner after execution of the contract with the MBE. For each such MBE, the Contractor shall provide the MBE's name, address, and telephone number, the nature of the work to be performed or materials or equipment to be supplied by the MBE, whether the MBE is certified by the South Carolina Office of Small and Minority Business Assistance, and the value of the contract.

13.11 SEVERABILITY

If any provision or any part of a provision of the Contract Documents shall be finally determined to be superseded, invalid, illegal, or otherwise unenforceable pursuant to any applicable Legal Requirements, such determination shall not impair or otherwise affect the validity, legality, or enforceability of the remaining provision or parts of the provision of the Contract Documents, which shall remain in full force and effect as if the unenforceable provision or part were deleted.

13.12 ILLEGAL IMMIGRATION

Contractor certifies and agrees that it will comply with the applicable requirements of Title 8, Chapter 14 of the South Carolina Code of Laws and agrees to provide to the State upon request any documentation required to establish either: (a) that Title 8, Chapter 14 is inapplicable both to Contractor and its subcontractors or sub-subcontractors; or (b) that Contractor and its subcontractors or sub-subcontractors are in compliance with Title 8, Chapter 14. Pursuant to Section 8-14-60, "A person who knowingly makes or files any false, fictitious, or fraudulent document, statement, or report pursuant to this chapter is guilty of a felony, and, upon conviction, must be fined within the discretion of the court or imprisoned for not more than five years, or both." Contractor agrees to include in any contracts with its subcontractors language requiring its subcontractors to (a) comply with the applicable requirements of Title 8, Chapter 14, and (b) include in their contracts with the sub-subcontractors language requiring the sub-subcontractors to comply with the applicable requirements of Title 8, Chapter 14. (An overview is available at www.procurement.sc.gov)

13.13 SETOFF

The Owner shall have all of its common law, equitable, and statutory rights of set-off.

13.14 DRUG-FREE WORKPLACE

The Contractor certifies to the Owner that Contractor will provide a Drug-Free Workplace, as required by Title 44, Chapter 107 of the South Carolina Code of Laws, as amended.

13.15 FALSE CLAIMS

According to the S.C. Code of Laws § 16-13-240, "a person who by false pretense or representation obtains the signature of a person to a written instrument or obtains from another person any chattel, money, valuable security, or other property, real or personal, with intent to cheat and defraud a person of that property is guilty" of a crime.

13.16 NON-INDEMNIFICATION:

Any term or condition is void to the extent it requires the State to indemnify anyone. It is unlawful for a person charged with disbursements of state funds appropriated by the General Assembly to exceed the amounts and purposes stated in the appropriations. (§ 11-9-20) It is unlawful for an authorized public officer to enter into a contract for a purpose in which the sum is in excess of the amount appropriated for that purpose. It is unlawful for an authorized public officer to divert or appropriate the funds arising from any tax levied and collected for any one fiscal year to the payment of an indebtedness contracted or incurred for a previous year. (§ 11-1-40)

3.111 *Delete Section 14.1.1 and substitute the following:*

14.1.1 The Contractor may terminate the Contract if the Work is stopped for a period of 45 consecutive days through no act or fault of the Contractor or a Subcontractor, Sub-subcontractor or their agents or employees or any other persons or entities performing portions of the Work under direct or indirect contract with the Contractor, for any of the following reasons:

- .1** Issuance of an order of a court or other public authority having jurisdiction that requires substantially all Work to be stopped; or

OSE FORM 00811**STANDARD SUPPLEMENTARY CONDITIONS**

- .2 An act of government, such as a declaration of national emergency that requires substantially all Work to be stopped.
- .3 Because the Architect has not issued a Certificate for Payment and has not notified the Contractor of the reason for withholding certification as provided in Section 9.4.1, or because the Owner has not made payment on a Certificate for Payment within the time stated in the Contract Documents and the Contractor has stopped work in accordance with Section 9.7

3.112 *Insert the following at the end of Section 14.1.3:*

Any adjustment to the Contract Sum pursuant to this Section shall be made in accordance with the requirements of Article 7.

3.113 *In Section 14.1.4, replace the word “repeatedly” with the word “persistently.”***3.114** *Delete Section 14.2.1 and substitute the following:***14.2.1** The Owner may terminate the Contract if the Contractor

- .1 repeatedly refuses or fails to supply enough properly skilled workers or proper materials, or otherwise fails to prosecute the Work, or any separable part of the Work, with the diligence, resources and skill that will ensure its completion within the time specified in the Contract Documents, including any authorized adjustments;
- .2 fails to make payment to Subcontractors for materials or labor in accordance with the Contract Documents and the respective agreements between the Contractor and the Subcontractors;
- .3 repeatedly disregards applicable laws, statutes, ordinances, codes, rules and regulations, or lawful orders of a public authority; or
- .4 otherwise is guilty of substantial breach of a provision of the Contract Documents.

3.115 *In Section 14.2.2, delete the parenthetical statement “, upon certification by the Initial Decision Maker that sufficient cause exists to justify such action,” immediately following the word “Owner” in the first line.***3.116** *In Section 14.2.4, replace the words “Initial Decision Maker” with the word “Architect”***3.117** *Add the following Section 14.2.5:*

14.2.5 If, after termination for cause, it is determined that the Owner lacked justification to terminate under Section 14.2.1, or that the Contractor’s default was excusable, the rights and obligations of the parties shall be the same as if the termination had been issued for the convenience of the Owner under Section 14.4.

3.118 *Delete the second sentence of Section 14.3.2 and substitute the following:*

Any adjustment to the Contract Sum made pursuant to this section shall be made in accordance with the requirements of Article 7.3.3.

3.119 *Delete Section 14.4.1 and substitute the following:*

14.4.1 The Owner may, at any time, terminate the Contract, in whole or in part for the Owner’s convenience and without cause. The Owner shall give written notice of the termination to the Contractor specifying the part of the Contract terminated and when termination becomes effective.

3.120 *Delete Section 14.4.2 and substitute the following:*

14.4.2 Upon receipt of written notice from the Owner of such termination for the Owner’s convenience, the Contractor shall

- .1 cease operations as directed by the Owner in the notice;
- .2 take actions necessary, or that the Owner may direct, for the protection and preservation of the Work;

OSE FORM 00811**STANDARD SUPPLEMENTARY CONDITIONS**

- .3 except for Work directed to be performed prior to the effective date of termination stated in the notice, terminate all existing subcontracts and purchase orders and enter into no further subcontracts and purchase orders; and
- .4 complete the performance of the Work not terminated, if any.

3.121 *Delete Section 14.4.3 and substitute the following:*

14.4.3 In case of such termination for the Owner's convenience, the Contractor shall be entitled to receive payment for Work executed, costs incurred by reason of such termination, and any other adjustments otherwise allowed by the Contract. Any adjustment to the Contract Sum made pursuant to this Section 14.4 shall be made in accordance with the requirements of Article 7.3.3.

3.122 *Add the following Sections 14.4.4, 14.4.5, and 14.5:*

14.4.4 Contractor's failure to include an appropriate termination for convenience clause in any subcontract shall not (i) affect the Owner's right to require the termination of a subcontract, or (ii) increase the obligation of the Owner beyond what it would have been if the subcontract had contained an appropriate clause.

14.4.5 Upon written consent of the Contractor, the Owner may reinstate the terminated portion of this Contract in whole or in part by amending the notice of termination if it has been determined that:

- .1 the termination was due to withdrawal of funding by the General Assembly, Governor, or Budget and Control Board or the need to divert project funds to respond to an emergency as defined by Regulation 19-445.2110(B) of the South Carolina Code of Regulations, as amended;
- .2 funding for the reinstated portion of the work has been restored;
- .3 circumstances clearly indicate a requirement for the terminated work; and
- .4 reinstatement of the terminated work is advantageous to the Owner.

14.5 CANCELLATION AFTER AWARD BUT PRIOR TO PERFORMANCE

Pursuant to Title 11, Chapter 35 and Regulation 19-445.2085 of the South Carolina Code of Laws and Regulations, as amended, this contract may be canceled after award but prior to performance.

3.123 *Insert the following sentence after the second sentence of Section 15.1.1:*

A voucher, invoice, payment application or other routine request for payment that is not in dispute when submitted is not a Claim under this definition.

3.124 *Delete Section 15.1.2 and substitute the following:***15.1.2 NOTICE OF CLAIMS**

Claims by either the Owner or Contractor must be initiated by written notice to the other party and to the Architect. Such notice shall include sufficient information to advise the Architect and other party of the circumstances giving rise to the claim, the specific contractual adjustment or relief requested and the basis of such request. Claims by either party arising prior to the date final payment is due must be initiated within 21 days after occurrence of the event giving rise to such Claim or within 21 days after the claimant first recognizes the condition giving rise to the Claim, whichever is later except as stated for adverse weather days in Section 15.1.5.2. By failing to give written notice of a Claim within the time required by this Section, a party expressly waives its claim.

3.125 *Delete Section 15.1.3 and substitute the following:***15.1.3 CONTINUING CONTRACT PERFORMANCE**

Pending final resolution of a Claim, including any administrative review allowed under Section 15.6, except as otherwise agreed in writing or as provided in Section 9.7 and Article 14, the Contractor shall proceed diligently with performance of the Contract and the Owner shall continue to make payments in accordance with the Contract Documents. The Architect will issue Certificates for Payment in accordance with the initial decisions and determinations of the Architect.

OSE FORM 00811**STANDARD SUPPLEMENTARY CONDITIONS**

3.126 *Insert the following at the end of Section 15.1.5.1:*

Claims for an increase in the Contract Time shall be based on one additional calendar day for each full calendar day that the Contractor is prevented from working.

3.127 *Insert the following Sub-Sections at the end of Section 15.1.5.2:*

- .1** Claims for adverse weather shall be based on actual weather conditions at the job site or other place of performance of the Work, as documented in the Contractor's job site log.
- .2** For the purpose of this Contract, a total of five (5) calendar days per calendar month (non-cumulative) shall be anticipated as "adverse weather" at the job site, and such time will not be considered justification for an extension of time. If, in any month, adverse weather develops beyond the five (5) days, the Contractor shall be allowed to claim additional days to compensate for the excess weather delays only to the extent of the impact on the approved construction schedule. The remedy for this condition is for an extension of time only and is exclusive of all other rights and remedies available under the Contract Documents or imposed or available by law.
- .3** The Contractor shall submit monthly with their pay application all claims for adverse weather conditions that occurred during the previous month. The Architect shall review each monthly submittal in accordance with Section 15.5 and inform the Contractor and the Owner promptly of its evaluation. Approved days shall be included in the next Change Order issued by the Architect. Adverse weather conditions not claimed within the time limits of this Subparagraph shall be considered to be waived by the Contractor. Claims will not be allowed for adverse weather days that occur after the scheduled (original or adjusted) date of Substantial Completion.

3.128 *Delete Section 15.1.6 and substitute the following:***15.1.6 CLAIMS FOR LISTED DAMAGES**

Notwithstanding any other provision of the Contract Documents, including Section 1.2.1, but subject to a duty of good faith and fair dealing, the Contractor and Owner waive Claims against each other for listed damages arising out of or relating to this Contract.

15.1.6.1 For the Owner, listed damages are (i) lost revenue and profit, (ii) losses resulting from injury to business or reputation, (iii) additional or escalated overhead and administration expenses, (iv) additional financing costs, (v) costs suffered by a third party unable to commence work, (vi) attorney's fees, (vii) any interest, except to the extent allowed by Section 13.6 (Interest), (viii) lost revenue and profit for lost use of the property, (ix) costs resulting from lost productivity or efficiency.

15.1.6.2 For the Contractor, listed damages are (i) lost revenue and profit, (ii) losses resulting from injury to business or reputation, (iii) additional or escalated overhead and administration expenses, (iv) additional financing costs, (v) attorney's fees, (vi) any interest, except to the extent allowed by Section 13.6 (Interest); (vii) unamortized equipment costs; and, (viii) losses incurred by subcontractors for the types of damages the Contractor has waived as against the Owner. Without limitation, this mutual waiver is applicable to all damages due to either party's termination in accordance with Article 14.

15.1.6.3 Nothing contained in this Section shall be deemed to preclude an award of liquidated damages, when applicable, in accordance with the requirements of the Contract Documents. This mutual waiver is not applicable to amounts due or obligations under Section 3.18 (Indemnification).

3.129 *Add the following Section 15.1.7:***15.1.7 WAIVER OF CLAIMS AGAINST THE ARCHITECT**

Notwithstanding any other provision of the Contract Documents, including Section 1.2.1, but subject to a duty of good faith and fair dealing, the Contractor waives all claims against the Architect and any other design professionals who provide design and/or project management services to the Owner, either directly or as independent contractors or subcontractors to the Architect, for listed damages arising out of or relating to this

OSE FORM 00811**STANDARD SUPPLEMENTARY CONDITIONS**

Contract. The listed damages are (i) lost revenue and profit, (ii) losses resulting from injury to business or reputation, (iii) additional or escalated overhead and administration expenses, (iv) additional financing costs, (v) attorney's fees, (vi) any interest; (vii) unamortized equipment costs; and, (viii) losses incurred by subcontractors for the types of damages the Contractor has waive as against the Owner. This mutual waiver is not applicable to amounts due or obligations under Section 3.18 (Indemnification).

3.130 *Delete the language of Sections 15.2, 15.3, and 15.4, including all Sub-Sections, and substitute the word "Reserved" for the deleted language of each Section and Sub-Section.*

3.131 *Add the following Sections 15.5 and 15.6 with their sub-sections:*

**15.5 CLAIM AND DISPUTES - DUTY OF COOPERATION, NOTICE, AND ARCHITECTS
INITIAL DECISION**

15.5.1 Contractor and Owner are fully committed to working with each other throughout the Project to avoid or minimize claims. To further this goal, Contractor and Owner agree to communicate regularly with each other and the Architect at all times notifying one another as soon as reasonably possible of any issue that if not addressed may cause loss, delay, and/or disruption of the Work. If claims do arise, Contractor and Owner each commit to resolving such claims in an amicable, professional, and expeditious manner to avoid unnecessary losses, delays, and disruptions to the Work.

15.5.2 Claims shall first be referred to the Architect for initial decision. An initial decision shall be required as a condition precedent to resolution pursuant to Section 15.6 of any Claim arising prior to the date of final payment, unless 30 days have passed after the Claim has been referred to the Architect with no decision having been rendered, or after all the Architect's requests for additional supporting data have been answered, whichever is later. The Architect will not address claims between the Contractor and persons or entities other than the Owner.

15.5.3 The Architect will review Claims and within ten days of the receipt of a Claim (1) request additional supporting data from the claimant or a response with supporting data from the other party or (2) render an initial decision in accordance with Section 15.5.5.

15.5.4 If the Architect requests a party to provide a response to a Claim or to furnish additional supporting data, such party shall respond, within ten days after receipt of such request, and shall either (1) provide a response on the requested supporting data, (2) advise the Architect when the response or supporting data will be furnished or (3) advise the Architect that all supporting data has already been provided. Upon receipt of the response or supporting data, the Architect will render an initial decision in accordance with Section 15.5.5.

15.5.5 The Architect will render an initial decision in writing; (1) stating the reasons therefor; and (2) notifying the parties of any change in the Contract Sum or Contract Time or both. The Architect will deliver the initial decision to the parties within two weeks of receipt of any response or supporting data requested pursuant to Section 16.4, or within such longer period as may be mutually agreeable to the parties. If the parties accept the initial decision, the Architect shall prepare a Change Order with appropriate supporting documentation for the review and approval of the parties and the Office of State Engineer. If either the Contractor, Owner, or both, disagree with the initial decision, the Contractor and Owner shall proceed with dispute resolution in accordance with the provisions of Section 15.6.

15.5.6 In the event of a Claim against the Contractor, the Owner may, but is not obligated to, notify the surety, if any, of the nature and amount of the Claim. If the Claim relates to a possibility of a Contractor's default, the Owner may, but is not obligated to, notify the surety and request the surety's assistance in resolving the controversy.

15.6 DISPUTE RESOLUTION

15.6.1 If a claim is not resolved pursuant to Section 15.5 to the satisfaction of either party, both parties shall attempt to resolve the dispute at the field level through discussions between Contractor's Representative and Owner's Representative. If a dispute cannot be resolved through Contractor's Representative and Owner's Representative, then the Contractor's Senior Representative and the Owner's Senior Representative, upon the request of either party, shall meet as soon as conveniently possible, but in no case later than twenty-one days after such a request is made, to attempt to resolve such dispute. Prior to any meetings between the Senior

OSE FORM 00811

STANDARD SUPPLEMENTARY CONDITIONS

Representatives, the parties will exchange relevant information that will assist the parties in resolving their dispute. The meetings required by this Section are a condition precedent to resolution pursuant to Section 15.6.2.

15.6.2 If after meeting in accordance with the provisions of Section 15.6.1, the Senior Representatives determine that the dispute cannot be resolved on terms satisfactory to both the Contractor and the Owner, then either party may submit the dispute by written request to South Carolina’s Chief Procurement Officer for Construction (CPOC). Except as otherwise provided in Article 15, all claims, claims, or controversies relating to the Contract shall be resolved exclusively by the appropriate Chief Procurement Officer in accordance with Title 11, Chapter 35, Article 17 of the South Carolina Code of Laws, or in the absence of jurisdiction, only in the Court of Common Pleas for, or in the absence of jurisdiction a federal court located in, Richland County, State of South Carolina. Contractor agrees that any act by the State regarding the Contract is not a waiver of either the State’s sovereign immunity or the State’s immunity under the Eleventh Amendment of the United State’s Constitution.

15.6.3 If any party seeks resolution to a dispute pursuant to Section 15.6.2, the parties shall participate in non-binding mediation to resolve the claim. If the claim is governed by Title 11, Chapter 35, Article 17 of the South Carolina Code of Laws as amended and the amount in controversy is \$100,000.00 or less, the CPOC shall appoint a mediator, otherwise, the mediation shall be conducted by an impartial mediator selected by mutual agreement of the parties, or if the parties cannot so agree, a mediator designated by the American Arbitration Association (“AAA”) pursuant to its Construction Industry Mediation Rules. The mediation will be governed by and conducted pursuant to a mediation agreement negotiated by the parties or, if the parties cannot so agree, by procedures established by the mediator.

15.6.4 Without relieving any party from the other requirements of Sections 15.5 and 15.6, either party may initiate proceedings in the appropriate forum prior to initiating or completing the procedures required by Sections 15.5 and 15.6 if such action is necessary to preserve a claim by avoiding the application of any applicable statutory period of limitation or repose.

15.6.5 SERVICE OF PROCESS

Contractor consents that any papers, notices, or process necessary or proper for the initiation or continuation of any claims, claims, or controversies relating to the Contract; for any court action in connection therewith; or for the entry of judgment on any award made, may be served on Contractor by certified mail (return receipt requested) addressed to Contractor at the address provided for the Contractor’s Senior Representative or by personal service or by any other manner that is permitted by law, in or outside South Carolina. Notice by certified mail is deemed duly given upon deposit in the United States mail.

3.132 Add the following Article 16:

ARTICLE 16 PROJECT-SPECIFIC REQUIREMENTS AND INFORMATION

16.1. Inspection Requirements: *(Indicate the inspection services required by the Contract)*

- Special Inspections are required and are not part of the Contract Sum. *(see section 01400)*
- Building Inspections are required and are not part of the Contract Sum. *(see section 01400)*
- Building Inspections are required and are part of the Contract Sum.

The inspections required for this Work are :
(Indicate which services are required and the provider)

- Civil: none
- Structural: Owner
- Mechanical: Owner
- Plumbing: Owner
- Electrical: Owner
- Gas: none
- Other *(list)*: none

Remarks: All inspections provided by owner

OSE FORM 00811**STANDARD SUPPLEMENTARY CONDITIONS**

16.1.1 Contractor shall schedule and request inspections in an orderly and efficient manner and shall notify the Owner whenever the Contractor schedules an inspection in accordance with the requirements of Section 16.1. Contractor shall be responsible for the cost of inspections scheduled and conducted without the Owner's knowledge and for any increase in the cost of inspections resulting from the inefficient scheduling of inspections.

16.2 List Cash Allowances, if any. *(Refer to attachments as needed. If none, enter NONE)*

NONE

16.3. Requirements for Record Drawings, if any. *(Refer to attachments as needed. If none, enter NONE)*

Specification Section 017839 Project Record Documents

16.4. Requirements for Shop Drawings and other submittals, if any, including number, procedure for submission, list of materials to be submitted, etc. *(Refer to attachments as needed. If none, enter NONE)*

Specification Section 013100 Project Management & Coordination

16.5. Requirements for signage, on-site office or trailer, utilities, restrooms, etc., in addition to the Contract, if any. *(Refer to attachments as needed. If none, enter NONE)*

EDA Construction Site Sign Specifications

16.6. Requirements for Project Cleanup in addition to the Contract, if any. *(Refer to attachments as needed. If none, enter NONE)*

NONE

16.7. List all attachments that modify these General Conditions. *(If none, enter NONE)*

Davis-Bacon Wage Rates (General Decision Number: SC150036)

Certification Regarding Lobbying (required for all contracts in which Federal funds exceed \$100,000)

Notice of Requirements for Affirmative Action to Ensure Equal Employment Opportunity

EDA Contracting Provisions for Construction Projects

EDA Construction Site Sign Specifications

Buy American Clause

KNOW ALL MEN BY THESE PRESENTS, that *(Insert full name or legal title and address of Contractor)*

Name: _____
Address: _____

hereinafter referred to as "Contractor", and *(Insert full name and address of principal place of business of Surety)*

Name: _____
Address: _____

hereinafter called the "surety", are jointly and severally held and firmly bound unto *(Insert full name and address of Agency)*

Name: Spartanburg Community College
Address: Post Office Drawer 4386
Spartanburg, SC 29305

hereinafter referred to as "Agency", or its successors or assigns, the sum of _____ (\$ _____), being the sum of the Bond to which payment to be well and truly made, the Contractor and Surety bind themselves, their heirs, executors, administrators, successors and assigns, jointly and severally, firmly by these presents.

WHEREAS, Contractor has by written agreement dated _____ entered into a contract with Agency to construct

State Project Name: Tyger River CBED Renovation

State Project Number: H59-6088-JM

Brief Description of Awarded Work, as found on the SE-330, Bid Form: Complete interior renovation of a portion of an existing campus building to include selective demolition, new interior partitions, doors, windows, finishes, ceilings, mechanical systems, lighting, power, data and fire protection systems.

in accordance with Drawings and Specifications prepared by *(Insert full name and address of A/E)*

Name: Craig Gaulden Davis
Address: 19 Washington Park
Greenville, SC 29601

which agreement is by reference made a part hereof, and is hereinafter referred to as the Contract.

IN WITNESS WHEREOF, Surety and Contractor, intending to be legally bound hereby, subject to the terms stated herein, do each cause this Performance Bond to be duly executed on its behalf by its authorized officer, agent or representative.

DATED this _____ day of _____, 2_____, BOND NUMBER _____
(shall be no earlier than Date of Contract)

CONTRACTOR

SURETY

By: _____
(Seal)

By: _____
(Seal)

Print Name: _____

Print Name: _____

Print Title: _____

Print Title: _____
(Attach Power of Attorney)

Witness: _____

Witness: _____

(Additional Signatures, if any, appear on attached page)

Performance Bond

NOW, THEREFORE, THE CONDITION OF THIS OBLIGATION IS SUCH THAT:

1. The Contractor and the Surety, jointly and severally, bind themselves, their heirs, executors, administrators, successors and assigns to the Agency for the full and faithful performance of the contract, which is incorporated herein by reference

2. If the Contractor performs the contract, the Surety and the Contractor have no obligation under this Bond, except to participate in conferences as provided in paragraph 3.1.

3. The Surety's obligation under this Bond shall arise after:

3.1 The Agency has notified the Contractor and the Surety at the address described in paragraph 10 below, that the Agency is considering declaring a Contractor Default and has requested and attempted to arrange a conference with the Contractor and the Surety to be held not later than 15 days after receipt of such notice to discuss methods of performing the Contract. If the Agency, the Contractor and the Surety agree, the Contractor shall be allowed a reasonable time to perform the Contract, but such an agreement shall not waive the Agency's right, if any, subsequently to declare a Contractor Default; or

3.2 The Agency has declared a Contractor Default and formally terminated the Contractor's right to complete the Contract.

4. The Surety shall, within 15 days after receipt of notice of the Agency's declaration of a Contractor Default, and at the Surety's sole expense, take one of the following actions:

4.1 Arrange for the Contractor, with consent of the Agency, to perform and complete the Contract; or

4.2 Undertake to perform and complete the Contract itself, through its agents or through independent contractors; or

4.3 Obtain bids or negotiated proposals from qualified contractors acceptable to the Agency for a contract for performance and completion of the Contract, arrange for a contract to be prepared for execution by the Agency and the contractor selected with the Agency's concurrence, to be secured with performance and payment bonds executed by a qualified surety equivalent to the Bonds issued on the Contract, and pay to the Agency the amount of damages as described in paragraph 7 in excess of the Balance of the Contract Sum incurred by the Agency resulting from the Contractor Default; or

4.4 Waive its right to perform and complete, arrange for completion, or obtain a new contractor, and:

4.4.1 After investigation, determine the amount for which it may be liable to the Agency and, within 60 days of waiving its rights under this paragraph, tender payment thereof to the Agency; or

4.4.2 Deny liability in whole or in part and notify the Agency, citing the reasons therefore.

5. Provided Surety has proceeded under paragraphs 4.1, 4.2, or 4.3, the Agency shall pay the Balance of the Contract Sum to either:

5.1 Surety in accordance with the terms of the Contract; or

5.2 Another contractor selected pursuant to paragraph 4.3 to perform the Contract.

5.3 The balance of the Contract Sum due either the Surety or another contractor shall be reduced by the amount of damages as described in paragraph 7.

6. If the Surety does not proceed as provided in paragraph 4 with reasonable promptness, the Surety shall be deemed to be in default on this Bond 15 days after receipt of written notice from the Agency to the Surety demanding that the Surety perform its obligations under this Bond, and the Agency shall be entitled to enforce any remedy available to the Agency.

6.1 If the Surety proceeds as provided in paragraph 4.4, and the

Agency refuses the payment tendered or the Surety has denied liability, in whole or in part, then without further notice the Agency shall be entitled to enforce any remedy available to the Agency.

6.2 Any dispute, suit, action or proceeding arising out of or relating to this Bond shall be governed by the Dispute Resolution process defined in the Contract Documents and the laws of the State of South Carolina.

7. After the Agency has terminated the Contractor's right to complete the Contract, and if the Surety elects to act under paragraph 4.1, 4.2, or 4.3 above, then the responsibilities of the Surety to the Agency shall be those of the Contractor under the Contract, and the responsibilities of the Agency to the Surety shall those of the Agency under the Contract. To a limit of the amount of this Bond, but subject to commitment by the Agency of the Balance of the Contract Sum to mitigation of costs and damages on the Contract, the Surety is obligated to the Agency without duplication for:

7.1 The responsibilities of the Contractor for correction of defective Work and completion of the Contract; and

7.2 Additional legal, design professional and delay costs resulting from the Contractor's Default, and resulting from the actions or failure to act of the Surety under paragraph 4; and

7.3 Damages awarded pursuant to the Dispute Resolution Provisions of the Contract. Surety may join in any Dispute Resolution proceeding brought under the Contract and shall be bound by the results thereof; and

7.4 Liquidated Damages, or if no Liquidated Damages are specified in the Contract, actual damages caused by delayed performance or non-performance of the Contractor.

8. The Surety shall not be liable to the Agency or others for obligations of the Contractor that are unrelated to the Contract, and the Balance of the Contract Sum shall not be reduced or set-off on account of any such unrelated obligations. No right of action shall accrue on this Bond to any person or entity other than the Agency or its heirs, executors, administrators, or successors.

9. The Surety hereby waives notice of any change, including changes of time, to the contract or to related subcontracts, purchase orders and other obligations.

10. Notice to the Surety, the Agency or the Contractor shall be mailed or delivered to the address shown on the signature page.

11. Definitions

11.1 Balance of the Contract Sum: The total amount payable by the Agency to the Contractor under the Contract after all proper adjustments have been made, including allowance to the Contractor of any amounts to be received by the Agency in settlement of insurance or other Claims for damages to which the Contractor is entitled, reduced by all valid and proper payments made to or on behalf of the Contractor under the Contract.

11.2 Contractor Default: Failure of the Contractor, which has neither been remedied nor waived, to perform the Contract or otherwise to comply with the terms of the Contract.

**SE-357
Labor and Material Payment Bond**

KNOW ALL MEN BY THESE PRESENTS, that *(Insert full name or legal title and address of Contractor)*

Name: _____
Address: _____

hereinafter referred to as "Contractor", and *(Insert full name and address of principal place of business of Surety)*

Name: _____
Address: _____

hereinafter called the "surety", are jointly and severally held and firmly bound unto *(Insert full name and address of Agency)*

Name: Spartenburg Community College
Address: Post Office Drawer 4386
Spartanburg, SC 29305

hereinafter referred to as "Agency", or its successors or assigns, the sum of _____ (\$ _____), being the sum of the Bond to which payment to be well and truly made, the Contractor and Surety bind themselves, their heirs, executors, administrators, successors and assigns, jointly and severally, firmly by these presents.

WHEREAS, Contractor has by written agreement dated _____ entered into a contract with Agency to construct

Project Name: Tyger River CBED Renovation
Project Number: H59-6088-JM
Brief Description of Awarded Work, as found on the SE-330, Bid Form: Complete interior renovation of a portion of an existing campus building to include selective demolition, new interior partitions, doors, windows, finishes, ceilings, mechanical systems, lighting, power, data and fire protection systems.

in accordance with Drawings and Specifications prepared by *(Insert full name and address of A/E)*

Name: Craig Gaulden Davis
Address: 19 Washington Park
Greenville, SC 29601

which agreement is by reference made a part hereof, and is hereinafter referred to as the Contract.

IN WITNESS WHEREOF, Surety and Contractor, intending to be legally bound hereby, subject to the terms stated herein, do each cause this Labor and Material Payment Bond to be duly executed on its behalf by its authorized officer, agent or representative.

DATED this _____ day of _____, 2_____, BOND NUMBER _____
(shall be no earlier than Date of Contract)

CONTRACTOR

SURETY

By: _____
(Seal)

By: _____
(Seal)

Print Name: _____

Print Name: _____

Print Title: _____

Print Title: _____
(Attach Power of Attorney)

Witness: _____

Witness: _____

(Additional Signatures, if any, appear on attached page)

SE-357**Labor and Material Payment Bond****NOW, THEREFORE, THE CONDITION OF THIS OBLIGATION IS SUCH THAT:**

1. The Contractor and the Surety, jointly and severally, bind themselves, their heirs, executors, administrators, successors and assigns to the Agency to pay for all labor, materials and equipment required for use in the performance of the Contract, which is incorporated herein by reference.
2. With respect to the Agency, this obligation shall be null and void if the Contractor:
 - 2.1 Promptly makes payment, directly or indirectly, for all sums due Claimants; and
 - 2.2 Defends, indemnifies and holds harmless the Agency from all claims, demands, liens or suits by any person or entity who furnished labor, materials or equipment for use in the performance of the Contract.
3. With respect to Claimants, this obligation shall be null and void if the Contractor promptly makes payment, directly or indirectly, for all sums due.
4. With respect to Claimants, and subject to the provisions of Title 29, Chapter 5 and the provisions of §11-35-3030(2)(c) of the SC Code of Laws, as amended, the Surety's obligation under this Bond shall arise as follows:
 - 4.1 Every person who has furnished labor, material or rental equipment to the Contractor or its subcontractors for the work specified in the Contract, and who has not been paid in full therefore before the expiration of a period of ninety (90) days after the date on which the last of the labor was done or performed by him or material or rental equipment was furnished or supplied by him for which such claim is made, shall have the right to sue on the payment bond for the amount, or the balance thereof, unpaid at the time of institution of such suit and to prosecute such action for the sum or sums justly due him.
 - 4.2 A remote claimant shall have a right of action on the payment bond upon giving written notice by certified or registered mail to the Contractor within ninety (90) days from the date on which such person did or performed the last of the labor or furnished or supplied the last of the material or rental equipment upon which such claim is made.
 - 4.3 Every suit instituted upon a payment bond shall be brought in a court of competent jurisdiction for the county or circuit in which the construction contract was to be performed, but no such suit shall be commenced after the expiration of one year after the day on which the last of the labor was performed or material or rental equipment was supplied by the person bringing suit.
5. When the Claimant has satisfied the conditions of paragraph 4, the Surety shall promptly and at the Surety's expense take the following actions:
 - 5.1 Send an answer to the Claimant, with a copy to the Agency, within sixty (60) days after receipt of the claim, stating the amounts that are undisputed and the basis for challenging any amounts that are disputed.
 - 5.2 Pay or arrange for payment of any undisputed amounts.
 - 5.3 The Surety's failure to discharge its obligations under this paragraph 5 shall not be deemed to constitute a waiver of defenses the Surety or Contractor may have or acquire as to a claim. However, if the Surety fails to discharge its obligations under this paragraph 5, the Surety shall indemnify the Claimant for the reasonable attorney's fees the Claimant incurs to recover any sums found to be due and owing to the Claimant.
6. Amounts owed by the Agency to the Contractor under the

Contract shall be used for the performance of the Contract and to satisfy claims, if any, under any Performance Bond. By the Contractor furnishing and the Agency accepting this Bond, they agree that all funds earned by the contractor in the performance of the Contract are dedicated to satisfy obligations of the Contractor and the Surety under this Bond, subject to the Agency's prior right to use the funds for the completion of the Work.

7. The Surety shall not be liable to the Agency, Claimants or others for obligations of the Contractor that are unrelated to the Contract. The Agency shall not be liable for payment of any costs or expenses of any claimant under this bond, and shall have under this Bond no obligations to make payments to, give notices on behalf of, or otherwise have obligations to Claimants under this Bond.

8. The Surety hereby waives notice of any change, including changes of time, to the Contract or to related Subcontracts, purchase orders and other obligations.

9. Notice to the Surety, the Agency or the Contractor shall be mailed or delivered to the addresses shown on the signature page. Actual receipt of notice by Surety, the Agency or the contractor, however accomplished, shall be sufficient compliance as of the date received at the address shown on the signature page.

10. By the Contractor furnishing and the Agency accepting this Bond, they agree that this Bond has been furnished to comply with the statutory requirements of the South Carolina Code of Laws, as amended, and further, that any provision in this Bond conflicting with said statutory requirements shall be deemed deleted herefrom and provisions conforming to such statutory or other legal requirement shall be deemed incorporated herein. The intent is that this Bond shall be construed as a statutory Bond and not as a common law bond.

11. Upon request of any person or entity appearing to be a potential beneficiary of this bond, the Contractor shall promptly furnish a copy of this Bond or shall permit a copy to be made.

12. Any dispute, suit, action or proceeding arising out of or relating to this Bond shall be governed by the laws of the State of South Carolina.

13. DEFINITIONS

13.1 Claimant: An individual or entity having a direct contract with the Contractor or with a Subcontractor of the Contractor to furnish labor, materials, or equipment for use in the performance of the Contract. The intent of this Bond shall be to include without limitation in the terms "labor, materials or equipment" that part of water, gas, power, light, heat, oil, gasoline, telephone service or rental equipment used in the Contract, architectural and engineering services required for performance of the Work of the Contractor and the Contractor's Subcontractors, and all other items for which a mechanic's lien might otherwise be asserted.

13.2 Remote Claimant: A person having a direct contractual relationship with a subcontractor of the Contractor or subcontractor, but no contractual relationship expressed or implied with the Contractor.

13.3 Contract: The agreement between the Agency and the Contractor identified on the signature page, including all Contract Documents and changes thereto.

CRAIG GAULDEN DAVIS

19 Washington Park
Greenville, South Carolina 26901

Digital Transfer Agreement

Digital Transfer Agreement to: _____
Project Name: Spartanburg Community College, Tyger River Campus, CBED Renovation
Project No. H59-6088-JM

This Agreement is entered into and agreed by, between and among Craig Gaulden & Davis Inc. (CGD) and _____ **(name of Consultant, Contractor, Construction Manager, Subcontractor, or Vendor, as applicable)** (Recipient (s) and is made in reference to the _____ **(Project)**.

Craig Gaulden Davis is providing at your request digital files of the architectural drawings for your use in developing your drawings related to **(PROJECT NAME)** subject to the following terms and conditions, this transfer will be provided to you without the Architect's title block information.

Craig Gaulden Davis makes no representation as to the compatibility of these files to your hardware or software applications. Any use or misuse of these files by you or others will be at your sole risk and without any liability or legal exposure to Craig Gaulden Davis.

You and your successors agree to make no claim and hereby waive, to the fullest extent permitted by law, any claim or cause of action of any nature against Craig Gaulden Davis, our officers, stockholders, employees or sub-consultants that may arise out of your use of these digital files. If this occurs the hard copy will prevail.

You shall, to the fullest extent permitted by law, indemnify and hold Craig Gaulden Davis, our officers, stockholders, employees or sub-contractors harmless against any and all cost, liabilities and damages including attorney's fees, court cost and any other costs associated from your use of these digital files. These digital files are not construction documents nor are they as-built or record drawings. Differences may occur between these digital files and the actual hard copy construction drawings and or actual field conditions.

Digital copies of our consultant drawings shall be requested through our consultant's offices. This transfer agreement has no bearing on your request for digital engineering files through our consultants. You may be requested to sign another agreement for transfer of digital files from our consultants.

Craig Gaulden Davis makes no representation as to the accuracy or the completeness of these files.

You and your successors are responsible for verifying the accuracy of these files and if any conflicts exist between these files and actual site conditions. By your use of these files you are not relieved of your responsibility to confirm, check and coordinate all dimensions, verify site conditions and coordinate with other trades.

Since it is possible for information on these digital files to be modified or altered, our office will remove all indication of ownership from the digital display on these files. We make no warranties either implied or expressed for these digital files.

Craig Gauden Davis shall be reimbursed a service fee of **\$100.00** per sheet. This cost shall be remitted with this agreement to our office prior to the issuance of these files. Craig Gauden Davis does not deem the delivery of these digital files to you for your intended use as a sale.

In no event shall Craig Gauden Davis be liable for any damages or losses as a result of your use or your successor's use of these files.

Please sign and date this transfer agreement and return to the offices of Craig Gauden Davis with payment in the amount noted above, if you are in agreement with the conditions of this agreement. These files will not be release until the payment amount has been received in our office.

Architect

By: _____
Title: _____
Date: _____

Contractor / Consultant

By: _____
Title: _____
Date: _____

**U. S. DEPARTMENT OF COMMERCE
ECONOMIC DEVELOPMENT ADMINISTRATION**



**EDA CONTRACTING PROVISIONS
FOR CONSTRUCTION PROJECTS**

These EDA Contracting Provisions for Construction Projects (EDA Contracting Provisions) are intended for use by recipients receiving federal assistance from the U. S. Department of Commerce - Economic Development Administration (EDA). They contain provisions specific to EDA and other federal provisions not normally found in non-federal contract documents. The requirements contained herein must be incorporated into all construction contracts and subcontracts funded wholly or in part with federal assistance from EDA.

TABLE OF CONTENTS

1. Definitions
2. Applicability
3. Federally Required Contract Provisions
4. Required Provisions Deemed Inserted
5. Inspection by EDA Representatives
6. Examination and Retention of Contractor's Records
7. Construction Schedule and Periodic Estimates
8. Contractor's Title to Material
9. Inspection and Testing of Materials
10. "OR EQUAL" Clause
11. Patent Fees and Royalties
12. Claims for Extra Costs
13. Contractor's and Subcontractor's Insurance
14. Contract Security Bonds
15. Labor Standards - Davis-Bacon and Related Acts
16. Labor Standards - Contract Work Hours and Safety Standards Act
17. Equal Employment Opportunity
18. Contracting with Small, Minority and Women's Businesses
19. Health, Safety and Accident Prevention
20. Conflict of Interest and Other Prohibited Interests
21. New Restrictions on Lobbying
22. Historical and Archaeological Data Preservation
23. Clean Air and Water
24. Use of Lead-Based Paints on Residential Structures
25. Energy Efficiency
26. Environmental Requirements
27. Debarment, Suspension, Ineligibility and Voluntary Exclusions
28. EDA Project Sign

1. **DEFINITIONS**

Agreement – The written instrument that is evidence of the agreement between the Owner and the Contractor overseeing the Work.

Architect/Engineer - The person or other entity engaged by the Recipient to perform architectural, engineering, design, and other services related to the work as provided for in the contract.

Contract – The entire and integrated written agreement between the Owner and the Contractor concerning the Work. The Contract supersedes prior negotiations, representations, or agreements, whether written or oral.

Contract Documents – Those items so designated in the Agreement. Only printed or hard copies of the items listed in the Agreement are Contract Documents.

Contractor – The individual or entity with whom the Owner has entered into the Agreement.

Drawings or Plans – That part of the Contract Documents prepared or approved by the Architect/Engineer that graphically shows the scope, extent, and character of the Work to be performed by the Contractor.

EDA - The United States of America acting through the Economic Development Administration of the U.S. Department of Commerce or any other person designated to act on its behalf. EDA has agreed to provide financial assistance to the Owner, which includes assistance in financing the Work to be performed under this Contract. Notwithstanding EDA's role, nothing in this Contract shall be construed to create any contractual relationship between the Contractor and EDA.

Owner – The individual or entity with whom the Contractor has entered into the Agreement and for whom the Work is to be performed.

Project – The total construction of which the Work to be performed under the Contract Documents may be the whole, or a part.

Recipient - An entity receiving Federal financial assistance from EDA, including any EDA-approved successor to the entity.

Specifications – That part of the Contract Documents consisting of written requirements for materials, equipment, systems, standards, and workmanship as applied to the Work, and certain administrative requirements and procedural matters applicable thereto.

Subcontractor – An individual or entity having direct contract with the Contractor or with any other Subcontractor for the performance of a part of the Work at the Site.

Work – The entire construction or the various separately identifiable parts thereof required to be provided under the Contract Documents. Work includes and is the result of performing or providing all labor, services, and documentation necessary to produce such construction and furnishing, installing, and incorporating all materials and equipment into such construction, all as required by the Contract Documents.

2. **APPLICABILITY**

The Project to which the construction work covered by this Contract pertains is being assisted by the United States of America through federal assistance provided by the U.S. Department of Commerce - Economic Development Administration (EDA). Neither EDA, nor any of its departments, entities, or employees is a party to this Contract. The following EDA Contracting Provisions are included in this Contract and all subcontracts or related instruments pursuant to the provisions applicable to such federal assistance from EDA.

3. **FEDERALLY REQUIRED CONTRACT PROVISIONS**

(a) Administrative, contractual, or legal remedies in instances where contractors violate or breach contract terms, and provide for such sanctions and penalties as may be appropriate (Contracts more than the simplified acquisition threshold - currently fixed at \$100,000. *See* 41 U.S.C. 403(11)).

(b) Termination for cause and for convenience by the Recipient including the manner by which it will be effected and the basis for settlement (all contracts in excess of \$10,000).

(c) Compliance with Executive Order 11246 of September 24, 1965, *Equal Employment Opportunity*, as amended by Executive Order 11375 of October 13, 1967 and as supplemented by Department of Labor regulations at 41 C.F.R. chapter 60 (applicable to all construction contracts awarded in excess of \$10,000 by recipients of federal assistance and their contractors or subrecipients).

(d) Compliance with the Copeland "Anti-Kickback" Act (18 U.S.C. § 874) as supplemented by Department of Labor regulations at 29 C.F.R. part 3 (all contracts and subgrants for construction or repair).

(e) Compliance with the Davis-Bacon Act (40 U.S.C. § 3145) as supplemented by Department of Labor regulations at 29 C.F.R. part 5 (construction contracts in excess of \$2,000 awarded by Recipients and subrecipients).

(f) Compliance with sections 103 and 107 of the Contract Work Hours and Safety Standards Act (40 U.S.C. §§ 327-330) as supplemented by Department of Labor regulations at 29 C.F.R. part 5. (construction contracts awarded by Recipients and subrecipients in excess of \$2,000, and in excess of \$2,500 for other contracts which involve the employment of mechanics or laborers)

(g) EDA requirements and regulations pertaining to reporting.

(h) EDA requirements and regulations pertaining to patent rights with respect to any discovery or invention which arises or is developed in the course of or under such contract.

(i) EDA requirements and regulations pertaining to copyrights and rights in data.

(j) Compliance with all applicable standards, orders, or requirements issued under section 306 of the Clear Air Act (42 U.S.C. § 7606), section 508 of the Clean Water Act (33 U.S.C. § 1368), Executive Order 11738, *Providing for Administration of the Clean Air Act and the Federal Water Pollution Control Act With Respect to Federal Contracts, Grants, or Loans*, and Environmental Protection Agency regulations at 48 C.F.R. part 15 (applicable to contracts, subcontracts, and subgrants of amounts in excess of \$ 100,000).

4. **REQUIRED PROVISIONS DEEMED INSERTED**

Each and every provision of law and clause required by law to be inserted in this contract shall be deemed to be inserted herein and the contract shall be read and enforced as though it were included herein, and if through mistake or otherwise any such provision is not inserted, or is not correctly inserted, then upon the application of either party the contract shall forthwith be physically amended to make such insertion of correction.

5. **INSPECTION BY EDA REPRESENTATIVES**

The authorized representatives and agents of EDA shall be permitted to inspect all work, materials, payrolls, personnel records, invoices of materials, and other relevant data and records.

6. **EXAMINATION AND RETENTION OF CONTRACTOR'S RECORDS**

(a) The Owner, EDA, or the Comptroller General of the United States, or any of their duly authorized representatives shall, generally until three years after final payment under this contract, have access to and the right to examine any of the Contractor's directly pertinent books, documents, papers, or other records involving transactions related to this contract for the purpose of making audit, examination, excerpts, and transcriptions.

(b) The Contractor agrees to include in first-tier subcontracts under this contract a clause substantially the same as paragraph (a) above. "Subcontract," as used in this clause, excludes purchase orders that do not exceed \$10,000.

(c) The periods of access and examination in paragraphs (a) and (b) above for records relating to (1) appeals under the disputes clause of this contract, (2) litigation or settlement of claims arising from the performance of this contract, or (3) costs and expenses of this contract to which the Owner, EDA, or Comptroller General or any of their duly authorized representatives has taken exception shall continue until disposition of such appeals, litigation, claims, or exceptions.

7. **CONSTRUCTION SCHEDULE AND PERIODIC ESTIMATES**

Immediately after execution and delivery of the contract, and before the first partial payment is made, the Contractor shall deliver to the Owner an estimated construction progress schedule in a form satisfactory to the Owner, showing the proposed dates of commencement and completion of each of the various subdivisions of work required under the Contract Documents and the anticipated amount of each monthly payment that will become due to the Contractor in accordance with the progress schedule. The Contractor also shall furnish the Owner (a) a detailed estimate giving a complete breakdown of the contract price and (b) periodic itemized estimates of work done for the purpose of making partial payments thereon. The costs employed in making up any of these schedules will be used only to determine the basis of partial payments and will not be considered as fixing a basis for additions to or deductions from the contract price.

8. **CONTRACTOR'S TITLE TO MATERIAL**

No materials, supplies, or equipment for the work shall be purchased by the Contractor or by any subcontractor that is subject to any chattel mortgage or under a conditional sale contract or other agreement by which an interest is retained by the seller. The Contractor warrants and guarantees that he/she has good title to all work, materials, and equipment used by him/her in the Work, free and clear of all liens, claims, or encumbrances.

9. **INSPECTION AND TESTING OF MATERIALS**

All materials and equipment used in the completion of the Work shall be subject to adequate inspection and testing in accordance with accepted standards. The laboratory or inspection agency shall be selected by the Owner. Materials of construction, particularly those upon which the strength and durability of any structure may depend, shall be subject to inspection and testing to establish conformance with specifications and suitability for intended uses.

10. **"OR EQUAL" CLAUSE**

Whenever a material, article, or piece of equipment is identified in the Contract Documents by reference to manufacturers' or vendors' names, trade names, catalogue numbers, etc., it is intended merely to establish a standard. Any material, article, or equipment of other manufacturers and vendors that will perform adequately the duties imposed by the general design will be considered equally acceptable provided the material, article, or equipment so proposed is, in the opinion of the Architect/Engineer, of equal substance and function. However, such substitution material, article, or equipment shall not be purchased or installed by the Contractor without the Architect/Engineer's written approval.

11. **PATENT FEES AND ROYALTIES**

(a) Contractor shall pay all license fees and royalties and assume all costs incident to the use in the performance of the Work or the incorporation in the Work of any invention, design, process, product, or device that is the subject of patent rights or copyrights held by others. If a particular invention, design, process, product, or device is specified in the Contract Documents for use in

the performance of the Work and if, to the actual knowledge of Owner or Engineer, its use is subject to patent rights or copyrights calling for the payment of any license fee or royalty to others, the existence of such rights shall be disclosed by the Owner in the Contract Documents.

(b) To the fullest extent permitted by Laws and Regulations, the Contractor shall indemnify and hold harmless the Owner and the Architect/Engineer, and the officers, directors, partners, employees, agents, consultants, and subcontractors of each and any of them from and against all claims, costs, losses, and damages (including but not limited to all fees and charges of engineers, architects, attorneys, and other professionals and all court or arbitration or other dispute resolution costs) arising out of or relating to any infringement of patent rights or copyrights incident to the use in the performance of the Work or resulting from the incorporation in the Work of any invention, design, process, product, or device not specified in the Contract Documents.

12. CLAIMS FOR EXTRA COSTS

No claims for extra work or cost shall be allowed unless the same was done in pursuance of a written order from the Architect/Engineer approved by the Owner.

13. CONTRACTORS AND SUBCONTRACTORS INSURANCE

(a) The Contractor shall not commence work under this Contract until the Contractor has obtained all insurance reasonably required by the Owner, nor shall the Contractor allow any subcontractor to commence work on his/her subcontract until the insurance required of the subcontractor has been so obtained and approved.

(b) Types of insurance normally required are:

- (1) Workmen's Compensation
- (2) Contractor's Public Liability and Property Damage
- (3) Contractor's Vehicle Liability
- (4) Subcontractors Public Liability, Property Damage and Vehicle Liability
- (5) Builder's Risk (Fire and Extended Coverage)

(c) **Scope of Insurance and Special Hazards:** The insurance obtained, which is described above, shall provide adequate protection for the Contractor and his/her subcontractors, respectively, against damage claims that may arise from operations under this contract, whether such operations be by the insured or by anyone directly or indirectly employed by him/her and also against any of the special hazards that may be encountered in the performance of this Contract.

(d) **Proof of Carriage of Insurance:** The Contractor shall furnish the Owner with certificates showing the type, amount, class of operations covered, effective dates, and dates of expiration of applicable insurance policies.

14. **CONTRACT SECURITY BONDS**

(a) If the amount of this Contract exceeds \$100,000, the Contractor shall furnish a performance bond in an amount at least equal to one hundred percent (100%) of the Contract price as security for the faithful performance of this Contract and also a payment bond in an amount equal to one hundred percent (100%) of the Contract price or in a penal sum not less than that prescribed by State, Territorial, or local law, as security for the payment of all persons performing labor on the Work under this Contract and furnishing materials in connection with this Contract. The performance bond and the payment bond may be in one or in separate instruments in accordance with local law. Before final acceptance, each bond must be approved by EDA. If the amount of this Contract does not exceed \$100,000, the Owner shall specify the amount of the payment and performance bonds.

(b) All bonds shall be in the form prescribed by the Contract Documents except as otherwise provided in applicable laws or regulations, and shall be executed by such sureties as are named in the current list of *Companies Holding Certificates of Authority as Acceptable Sureties on Federal Bonds and as Acceptable Reinsuring Companies* as published in Treasury Circular 570 (amended) by the Financial Management Service, Surety Bond Branch, U.S. Department of the Treasury. All bonds signed by an agent must be accompanied by a certified copy of the agent's authority to act. Surety companies executing the bonds must also be authorized to transact business in the state where the Work is located.

15. **LABOR STANDARDS - DAVIS-BACON AND RELATED ACTS**
(as required by section 601 of PWEDA)

(a) **Minimum Wages**

(1) All laborers and mechanics employed or working upon the site of the Work in the construction or development of the Project will be paid unconditionally and not less often than once a week, and without subsequent deduction or rebate on any account (except such payroll deductions as are permitted by regulations issued by the Secretary of Labor under the Copeland Act at 29 C.F.R. part 3, the full amount of wages and bona fide fringe benefits (or cash equivalents thereof) due at the time of payment computed at rates not less than those contained in the wage determination of the Secretary of Labor, which is attached hereto and made a part hereof, regardless of any contractual relationship that may be alleged to exist between the Contractor and such laborers and mechanics. Contributions made or costs reasonably anticipated for bona fide fringe benefits under Section 1(b)(2) of the Davis-Bacon Act on behalf of laborers or mechanics are considered wages paid to such laborers or mechanics, subject to the provisions of 29 C.F.R. § 5.5(a)(1)(iv); also, regular contributions made or costs incurred for more than a weekly period (but not less often than quarterly) under plans, funds, or programs, which cover the particular weekly period, are deemed to be constructively made or incurred during such weekly period. Such laborers and mechanics shall be paid the appropriate wage rate and fringe benefits on the wage determination for the classification of work actually performed, without regard to skill, except as provided in 29 C.F.R. § 5.5(a)(4). Laborers or mechanics performing work in more than one classification may be compensated at the

rate specified for each classification for the time actually worked therein, provided that the employer's payroll records accurately set forth the time spent in each classification in which work is performed. The wage determination (including any additional classification and wage rates determined under 29 C.F.R. § 5.5(a)(1)(ii) and the Davis-Bacon poster (WH-1321) shall be posted at all times by the contractor and its subcontractors at the site of the work in a prominent and accessible place where it can be easily seen by the workers.

(2) (i) Any class of laborers or mechanics to be employed under the Contract, but not listed in the wage determination, shall be classified in conformance with the wage determination. EDA shall approve an additional classification and wage rate and fringe benefits therefore only when the following criteria have been met:

(A) The work to be performed by the classification requested is not performed by a classification in the wage determination;

(B) The classification is utilized in the area by the construction industry; and

(C) The proposed wage rate, including any bona fide fringe benefits, bears a reasonable relationship to the wage rates contained in the wage determination.

(ii) If the Contractor and the laborers and mechanics to be employed in the classification (if known), or their representatives, and EDA or its designee agree on the classification and wage rate (including the amount designated for fringe benefits where appropriate), a report of the action taken shall be sent by EDA or its designee to the Administrator of the Wage and Hour Division, Employment Standards Administration, U.S. Department of Labor, Washington, D.C. 20210.

(iii) In the event the Contractor, the laborers or mechanics to be employed in the classification or their representatives, and EDA or its designee do not agree on the proposed classification and wage rate (including the amount designated for fringe benefits, where appropriate), EDA or its designee shall refer the questions, including the views of all interested parties and the recommendation of EDA or its designee, to the Administrator for determination.

(iv) The wage rate (including fringe benefits where appropriate) determined pursuant to paragraphs (a)(2)(ii) or (iii) of this section, shall be paid to all workers performing work in the classification under this contract from the first day on which work is performed in the classification.

(3) Whenever the minimum wage rate prescribed in the contract for a class of laborers or mechanics includes a fringe benefit which is not expressed as an hourly rate, the Contractor shall either pay the benefit as stated in the wage determination or shall pay another bona fide fringe benefit or an hourly cash equivalent thereof.

(4) If the Contractor does not make payments to a trustee or other third person, the Contractor may consider as part of the wages of any laborer or mechanic the amount of any costs reasonably anticipated in providing bona fide fringe benefits under a plan or program, provided, that the Secretary of Labor has found, upon the written request of the Contractor, that the applicable standards of the Davis-Bacon Act have been met. The Secretary of Labor may require the Contractor to set aside in a separate account assets for the meeting of obligations under the plan or program.

(b) Withholding

EDA or its designee shall upon its own action or upon written request of an authorized representative of the Department of Labor withhold or cause to be withheld from the Contractor under this Contract or any other federal contract with the same prime Contractor, or any other federally-assisted contract subject to Davis-Bacon prevailing wage requirements, which is held by the same prime contractor so much of the accrued payments or advances as may be considered necessary to pay laborers and mechanics, including apprentices, trainees and helpers, employed by the Contractor or any subcontractor the full amount of wages required by the Contract. In the event of failure to pay any laborer or mechanic, including any apprentice, trainee or helper employed or working on the site of the Work in the construction or development of the Project, all or part of the wages required by the Contract, EDA or its designee may, after written notice to the Contractor, sponsor, applicant, or owner, take such action as may be necessary to cause the suspension of any further payment, advance, or guarantee of funds until such violations have ceased. EDA or its designee may, after written notice to the Contractor, disburse such amounts withheld for and on account of the Contractor or subcontractor to the respective employees to whom they are due. The Comptroller General shall make such disbursements in the case of direct Davis-Bacon Act contracts.

(c) Payrolls and basic records

(1) Payrolls and basic records relating thereto shall be maintained by the Contractor during the course of the Work and preserved for a period of three years thereafter for all laborers and mechanics working at the site of the Work in the construction or development of the Project. Such records shall contain the name, address, and social security number of each such worker, his or her correct classification, hourly rates of wages paid (including rates of contributions or costs anticipated for bona fide fringe benefits or cash equivalents thereof of the types described in section 1(b) (2) (B) of the Davis-Bacon Act), daily and weekly number of hours worked, deductions made and actual wages paid. Whenever the Secretary of Labor has found under 29 C.F.R. § 5.5(a)(1)(iv) that the wages of any laborer or mechanic include the amount of any costs reasonably anticipated in providing benefits under a plan or program described in section 1(b)(2)(B) of the Davis-Bacon Act, the Contractor shall maintain records which show that the commitment to provide such benefits is enforceable, the plan or program is financially responsible, and the plan or program has been communicated in writing to the laborers or mechanics affected, and provide records that show the costs anticipated or the actual cost incurred in providing such benefits. Contractors employing apprentices or trainees under approved programs shall maintain written evidence of the registration of

apprenticeship programs and certification of trainee programs, the registration of the apprentices and trainees, and the ratios and wage rates prescribed in the applicable programs.

(2) (i) For each week in which Contract work is performed, the Contractor shall submit a copy of all payrolls to the Owner for transmission to EDA or its designee. The payrolls submitted shall set out accurately and completely all of the information required to be maintained under 29 C.F.R. part 5.5(a)(3)(i). This information may be submitted in any form desired. Optional Form WH-347 is available for this purpose. It may be purchased from the Superintendent of Documents (Federal Stock Number 029-005-00014-1), U.S. Government Printing Office, Washington, D.C. 20402; or downloaded from the U.S. Department of Labor's website at www.dol.gov/esa/forms/whd/index.htm. The prime Contractor is responsible for the submission of copies of payrolls by all subcontractors

(ii) Each payroll submitted shall be accompanied by a "Statement of Compliance," signed by the Contractor or subcontractor or his or her agent who pays or supervises the payment of the persons employed under the Contract and shall certify the following:

(A) That the payroll for the payroll period contains the information required to be maintained under 29 C.F.R. § 5.5(a)(3)(i) and that such information is correct and complete;

(B) That each laborer or mechanic (including each helper, apprentice, and trainee) employed on the Contract during the payroll period has been paid the full weekly wages earned, without rebate, either directly or indirectly, and that no deductions have been made either directly or indirectly from the full wages earned, other than permissible deductions as set forth in 29 C.F.R. part 3;

(C) That each laborer or mechanic has been paid not less than the applicable wage rates and fringe benefits or cash equivalents for the classification of work performed, as specified in the applicable wage determination incorporated into the Contract.

(iii) The weekly submission of a properly executed certification set forth on the reverse side of Optional Form WH-347 shall satisfy the requirement for submission of the "Statement of Compliance" required by paragraph 14(c)(ii) of this section.

(iv) The falsification of any of the above certifications may subject the Contractor or subcontractor to civil or criminal prosecution under section 1001 of Title 18 and section 231 of Title 31 of the U.S. Code.

(3) The Contractor or subcontractor shall make the records required under paragraph 15(c)(1) of this section available for inspection, copying, or transcription by authorized representatives of EDA or its designee or the Department of Labor, and shall permit such representatives to interview employees during working hours on the job. If the Contractor or subcontractor fails to submit the required records or to make them

available, EDA or its designee may, after written notice to the Contractor or Owner, take such action as may be necessary to cause the suspension of any further payment, advance, or guarantee of funds. Furthermore, failure to submit the required records upon request or to make such records available may be grounds for debarment action pursuant to 29 C.F.R. part 5.12.

(d) Apprentices and Trainees.

(1) Apprentices. Apprentices will be permitted to work at less than the predetermined rate for the work they performed when they are employed pursuant to and individually registered in a bona fide apprenticeship program registered with the U.S. Department of Labor, Employment and Training Administration, Bureau of Apprenticeship and Training, or with a State Apprenticeship Agency recognized by the Bureau, or if a person is employed in his or her first 90 days of probationary employment as an apprentice in such an apprenticeship program, who is not individually registered in the program, but who has been certified by the Bureau of Apprenticeship and Training or a State Apprenticeship Agency (where appropriate) to be eligible for probationary employment as an apprentice. The allowable ratio of apprentices to journeymen on the job site in any craft classification shall not be greater than the ratio permitted to the Contractor as to the entire work force under the registered program. Any worker listed on a payroll at an apprentice wage rate who is not registered or otherwise employed as stated above, shall be paid not less than the applicable wage rate on the wage determination for the classification of work actually performed. In addition, any apprentice performing work on the job site in excess of the ratio permitted under the registered program shall be paid not less than the applicable wage rate on the wage determination for the work actually performed. Where a Contractor is performing construction on a Project in a locality other than that in which its program is registered, the ratios and wage rates (expressed in percentages of the journeyman's hourly rate) specified in the Contractor's or subcontractor's registered program shall be observed. Every apprentice must be paid at not less than the rate specified in the registered program for the apprentice's level of progress, expressed as a percentage of the journeymen hourly rate specified in the applicable wage determination. Apprentices shall be paid fringe benefits in accordance with the provisions of the apprenticeship program. If the apprenticeship program does not specify fringe benefits, apprentices must be paid the full amount of fringe benefits listed on the wage determination for the applicable classification. If the Administrator determines that a different practice prevails for the applicable apprentice classification, fringes shall be paid in accordance with that determination. In the event the Bureau of Apprenticeship and Training, or a State Apprenticeship Agency recognized by the Bureau, withdraws approval of an apprenticeship program, the Contractor will no longer be permitted to utilize apprentices at less than the applicable predetermined rate for the work performed until an acceptable program is approved.

(2) Trainees. Except as provided in 29 C.F.R. § 5.16, trainees will not be permitted to work at less than the predetermined rate for the work performed unless they are employed pursuant to and individually registered in a program that has received prior approval, evidenced by formal certification by the U.S. Department of Labor, Employment and

Training Administration. The ratio of trainees to journeymen on the job site shall not be greater than permitted under the plan approved by the Employment and Training Administration. Every trainee must be paid at not less than the rate specified in the approved program for the trainee's level of progress, expressed as a percentage of the journeyman's hourly rate specified in the applicable wage determination. Trainees shall be paid fringe benefits in accordance with the provisions of the trainee program. If the trainee program does not mention fringe benefits, trainees shall be paid the full amount of fringe benefits listed on the wage determination unless the Administrator of the Wage and Hour Division determines that there is an apprenticeship program associated with the corresponding journeyman wage rate on the wage determination which provides for less than full fringe benefits for apprentices. Any employee listed on the payroll at a trainee rate who is not registered and participating in a training plan approved by the Employment and Training Administration shall be paid not less than the applicable wage rate on the wage determination for the classification of work actually performed. In addition, any trainee performing work on the job site in excess of the ratio permitted under the registered program shall be paid not less than the applicable wage rate on the wage determination for the work actually performed. In the event the Employment and Training Administration withdraws approval of a training program, the Contractor will no longer be permitted to utilize trainees at less than the applicable predetermined rate for the work performed until an acceptable program is approved.

(3) **Equal employment opportunity.** The utilization of apprentices, trainees and journeymen under this part shall be in conformity with the equal employment opportunity requirements of Executive Order 11246, *Equal Employment Opportunity*, as amended, and 29 C.F.R. part 30.

(e) **Compliance with Copeland Anti-Kickback Act Requirements.** The Contractor shall comply with the Copeland Anti-Kickback Act (18 U.S.C. § 874 and 40 U.S.C. § 276(c)) as supplemented by Department of Labor regulations (29 C.F.R. part 3, "Contractors and Subcontractors on Public Buildings or Public Works Financed in Whole or in Part by Loans or Grants of the United States"). The Act provides that the Contractor and any subcontractors shall be prohibited from inducing, by any means, any person employed in the construction, completion, or repair of public facilities, to give up any part of the compensation to which they are otherwise entitled. The Owner shall report all suspected or reported violations to EDA.

(f) **Subcontracts.** The Contractor and any subcontractors will insert in any subcontracts the clauses contained in 29 C.F.R. §§ 5.5(a)(1) through (10) and such other clauses as EDA or its designee may require, and also a clause requiring the subcontractors to include these clauses in any lower tier subcontracts. The prime Contractor shall be responsible for the compliance by any subcontractor or lower tier subcontractor with all the contract clauses in 29 C.F.R. part 5.5.

(g) **Contract termination; debarment.** The breach of the contract clauses in 29 C.F.R. part 5.5 may be grounds for termination of the contract, and for debarment as a Contractor and a subcontractor as provided in 29 C.F.R. § 5.12.

(h) **Compliance with Davis-Bacon and Related Act Requirements.** All rulings and interpretations of the Davis-Bacon and Related Acts contained in 29 C.F.R. parts 1, 3, and 5 are herein incorporated by reference in this contract.

(i) **Disputes concerning labor standards.** Disputes arising out of the labor standards provisions of this Contract shall not be subject to the general disputes clause of this Contract. Such disputes shall be resolved in accordance with the procedures of the Department of Labor set forth in 29 C.F.R. parts 5, 6, and 7. Disputes within the meaning of this clause include disputes between the contractor (or any of its subcontractors) and EDA or its designee, the U.S. Department of Labor, or the employees or their representatives.

(j) **Certification of Eligibility.**

(1) By entering into this Contract, the Contractor certifies that neither it nor any person or firm that has an interest in the Contractor's firm is a person or firm ineligible to be awarded Government contracts by virtue of section 3(a) of the Davis-Bacon Act or 29 C.F.R. § 5.12(a)(1).

(2) No part of this Contract shall be subcontracted to any person or firm ineligible for award of a Government contract by virtue of section 3(a) of the Davis-Bacon Act or 29 C.F.R. § 5.12(a)(1).

(3) The penalty for making false statements is prescribed in the U.S. Criminal Code, 18 U.S.C. § 1001.

16. **LABOR STANDARDS - CONTRACT WORK HOURS AND SAFETY STANDARDS ACT**

As used in this paragraph, the terms “laborers” and “mechanics” include watchmen and guards.

(a) **Overtime requirements.** No Contractor or subcontractor contracting for any part of the Contract work, which may require or involve the employment of laborers or mechanics, shall require or permit any such laborer or mechanic in any workweek in which that person is employed on such work to work in excess of forty hours in such workweek unless such laborer or mechanic receives compensation at a rate not less than one and one-half times the basic rate of pay for all hours worked in excess of forty hours in such workweek.

(b) **Violation; liability for unpaid wages, liquidated damages.** In the event of any violation of the clause set forth in paragraph (a) of this section, the Contractor and any subcontractor responsible therefore shall be liable for the unpaid wages. In addition, such Contractor and subcontractor shall be liable to the United States (in the case of work done under contract for the District of Columbia or a territory, to such District or to such territory), for liquidated damages. Such liquidated damages shall be computed with respect to each individual laborer or mechanic, including watchmen and guards, employed in violation of the clause set forth in paragraph (a) of this section, in the sum of \$10 for each calendar day on which such individual was required or

permitted to work in excess of the standard workweek of forty hours without payment of the overtime wages required by the clause set forth in paragraph (a) of this section.

(c) **Withholding for unpaid wages and liquidated damages.** EDA or its designee shall upon its own action or upon written request of an authorized representative of the Department of Labor withhold or cause to be withheld, from any monies payable on account of work performed by the Contractor or subcontractor under any such Contract or any other federal contract with the same prime Contractor, or any other federally-assisted contract subject to the Contract Work Hours and Safety Standards Act, which is held by the same prime Contractor such sums as may be determined to be necessary to satisfy any liabilities of such Contractor or subcontractor for unpaid wages and liquidated damages as provided in the clause set forth in paragraph (b) of this section.

(d) **Subcontracts.** The Contractor or subcontractor shall insert in any subcontracts the clauses set forth in paragraphs (a) through (c) of this section and also a clause requiring the subcontractors to include these clauses in any lower tier subcontracts. The prime Contractor shall be responsible for compliance by any subcontractor or lower tier subcontractor with the clauses set forth in paragraphs (a) through (c) of this section.

17. **EQUAL EMPLOYMENT OPPORTUNITY**

(a) The Recipient hereby agrees that it will incorporate or cause to be incorporated into any contract for construction work, or modification thereof, as defined in the regulations of the Secretary of Labor at 41 C.F.R. chapter 60, which is paid for in whole or in part with funds obtained from EDA, the following equal opportunity clause:

During the performance of this contract, the Contractor agrees as follows:

(1) The Contractor will not discriminate against any employee or applicant for employment because of race, color, religion, sex, or national origin. The Contractor will take affirmative action to ensure that applicants are employed, and that employees are treated during employment without regard to their race, color, religion, sex or national origin. Such action shall include, but not be limited to the following: Employment, upgrading, demotion, or transfer; recruitment or recruitment advertising; layoff or termination; rates of pay or other forms of compensation; and selection for training including apprenticeship. The Contractor agrees to post in conspicuous places available to employees and applicants for employment notices to be provided setting forth the provisions of this nondiscrimination clause.

(2) The Contractor will, in all solicitations or advertisements for employees placed by or on behalf of the Contractor state that all qualified applicants will receive consideration for employment without regard to race, color, religion, sex, or national origin.

(3) The Contractor will send to each labor union or representative of workers with which it has a collective bargaining agreement or other contract or understanding a notice to be provided advising the said labor union or workers representatives of the Contractor's

commitments hereunder, and shall post copies of the notice in conspicuous places available to employees and applicants for employment.

(4) The Contractor will comply with all provisions of Executive Order 11246 of September 24, 1965 and of the rules, regulations, and relevant orders of the Secretary of Labor.

(5) The Contractor will furnish all information and reports required by Executive Order 11246 of September 24, 1965, and pursuant to rules, regulations, and orders of the Secretary of Labor and will permit access to its books, records, and accounts by the Secretary of Labor for purposes of investigation to ascertain compliance with such rules, regulations, and orders.

(6) In the event of the Contractor's noncompliance with the nondiscrimination clauses of this Contract or with any of the said rules, regulations, or orders, this Contract may be canceled, terminated, or suspended in whole or in part and the Contractor may be declared ineligible for further Government contracts or federally-assisted construction contracts in accordance with procedures authorized in Executive Order 11246 of September 24, 1965, and such other sanctions may be imposed and remedies invoked as provided in Executive Order 11246 of September 24, 1965, or by rule, regulations or order of the Secretary of Labor, or as otherwise provided by law.

(7) The Contractor will include the portion of the sentence immediately preceding paragraph 17(a) (1) and the provisions of paragraphs 17(a)(1) through (6) in every subcontract or purchase order unless exempted by rules, regulations, or orders of the Secretary of Labor issued pursuant to section 204 of Executive Order 11246 of September 24, 1965, so that such provisions will be binding upon each subcontractor or vendor. The Contractor will take such action with respect to any subcontract or purchase order as EDA or the Secretary of Labor may direct as a means of enforcing such provisions, including sanctions for noncompliance. Provided, however, that in the event the Contractor becomes involved in or is threatened with litigation with or by a subcontractor or vendor as a result of such direction by EDA or the Secretary of Labor, the Contractor may request the United States to enter into such litigation to protect the interests of the United States.

(8) The Recipient further agrees that it will be bound by the above equal opportunity clause with respect to its own employment practices when it participates in federally-assisted construction work. Provided, however, that if the Recipient so participating is a State or local government, the above equal opportunity clause is not applicable to any agency, instrumentality, or subdivision of such government that does not participate in work on or under the Contract.

(9) The Recipient agrees that it will assist and cooperate actively with EDA and the Secretary of Labor in obtaining the compliance of contractors and subcontractors with the equal opportunity clause and the rules, regulations, and relevant orders of the Secretary of Labor, that it will furnish EDA and the Secretary of Labor such information as they may

require for the supervision of such compliance, and that it will otherwise assist EDA in the discharge of the EDA's primary responsibility for securing compliance.

(10) The Recipient further agrees that it will refrain from entering into any contract or contract modification subject to Executive Order 11246 of September 24, 1965, with a Contractor debarred from, or who has not demonstrated eligibility for, Government contracts and federally assisted construction contracts pursuant to the Executive order and will carry out such sanctions and penalties for violation of the equal opportunity clause as may be imposed upon contractors and subcontractors by EDA or the Secretary of Labor pursuant to Part II, Subpart D of the Executive order. In addition, the Recipient agrees that if it fails or refuses to comply with these undertakings, EDA may take any or all of the following actions: Cancel, terminate, or suspend in whole or in part this EDA financial assistance; refrain from extending any further assistance to the applicant under the program with respect to which the failure or refund occurred until satisfactory assurance of future compliance has been received from such applicant; and refer the case to the Department of Justice for appropriate legal proceedings.

(b) Exemptions to Above Equal Opportunity Clause (41 C.F.R. chapter 60):

(1) Contracts and subcontracts not exceeding \$10,000 (other than Government bills of lading) are exempt. The amount of the Contract, rather than the amount of the federal financial assistance, shall govern in determining the applicability of this exemption.

(2) Except in the case of subcontractors for the performance of construction work at the site of construction, the clause shall not be required to be inserted in subcontracts below the second tier.

(3) Contracts and subcontracts not exceeding \$10,000 for standard commercial supplies or raw materials are exempt.

18. **CONTRACTING WITH SMALL, MINORITY AND WOMEN'S BUSINESSES**

(a) If the Contractor intends to let any subcontracts for a portion of the work, the Contractor shall take affirmative steps to assure that small, minority and women's businesses are used when possible as sources of supplies, equipment, construction, and services.

(b) Affirmative steps shall consist of:

(1) Placing qualified small and minority businesses and women's business enterprises on solicitation lists;

(2) Ensuring that small and minority businesses and women's business enterprises are solicited whenever they are potential sources;

- (3) Dividing total requirements, when economically feasible, into smaller tasks or quantities to permit maximum participation by small and minority businesses and women's business enterprises;
- (4) Establishing delivery schedules, where the requirements of the contract permit, which encourage participation by small and minority businesses and women's business enterprises;
- (5) Using the services and assistance of the U.S. Small Business Administration, the Minority Business Development Agency of the U.S. Department of Commerce, and State and local governmental small business agencies;
- (6) Requiring each party to a subcontract to take the affirmative steps of this section; and
- (7) The Contractor is encouraged to procure goods and services from labor surplus area firms.

19. **HEALTH, SAFETY, AND ACCIDENT PREVENTION**

(a) In performing this contract, the Contractor shall:

- (1) Ensure that no laborer or mechanic shall be required to work in surroundings or under working conditions which are unsanitary, hazardous, or dangerous to their health and/or safety as determined under construction safety and health standards promulgated by the Secretary of Labor by regulation;
- (2) Protect the lives, health, and safety of other persons;
- (3) Prevent damage to property, materials, supplies, and equipment; and,
- (4) Avoid work interruptions.

(b) For these purposes, the Contractor shall:

- (1) Comply with regulations and standards issued by the Secretary of Labor at 29 C.F.R. part 1926. Failure to comply may result in imposition of sanctions pursuant to the Contract Work Hours and Safety Standards Act (40 U.S.C. § 3701 – 3708); and
- (2) Include the terms of this clause in every subcontract so that such terms will be binding on each subcontractor.

(c) The Contractor shall maintain an accurate record of exposure data on all accidents incident to work performed under this Contract resulting in death, traumatic injury, occupational disease, or damage to property, materials, supplies, or equipment, and shall report this data in the manner prescribed by 29 C.F.R. part 1904.

(d) The Owner shall notify the Contractor of any noncompliance with these requirements and of the corrective action required. This notice, when delivered to the Contractor or the Contractor's representative at the site of the Work, shall be deemed sufficient notice of the noncompliance and corrective action required. After receiving the notice, the Contractor shall immediately take corrective action. If the Contractor fails or refuses to take corrective action promptly, the Owner may issue an order stopping all or part of the Work until satisfactory corrective action has been taken. The Contractor shall not base any claim or request for equitable adjustment for additional time or money on any stop order issued under these circumstances.

(e) The Contractor shall be responsible for its subcontractors' compliance with the provisions of this clause. The Contractor shall take such action with respect to any subcontract as EDA, or the Secretary of Labor shall direct as a means of enforcing such provisions.

20. **CONFLICT OF INTEREST AND OTHER PROHIBITED INTERESTS**

(a) No official of the Owner who is authorized in such capacity and on behalf of the Owner to negotiate, make, accept, or approve, or to take part in negotiating, making, accepting, or approving any architectural, engineering, inspection, construction or material supply contract or any subcontract in connection with the construction of the Project, shall become directly or indirectly interested personally in this Contract or in any part hereof.

(b) No officer, employee, architect, attorney, engineer, or inspector of or for the Owner who is authorized in such capacity and on behalf of the Owner to exercise any legislative, executive, supervisory or other similar functions in connection with the construction of the Project, shall become directly or indirectly interested personally in this Contract or in any part thereof, any material supply contract, subcontract, insurance contract, or any other contract pertaining to the Project.

(c) The Contractor may not knowingly contract with a supplier or manufacturer if the individual or entity who prepared the Contract Documents has a corporate or financial affiliation with the supplier or manufacturer.

(d) The Owner's officers, employees, or agents shall not engage in the award or administration of this Contract if a conflict of interest, real or apparent, may be involved. Such a conflict may arise when: (i) the employee, officer or agent; (ii) any member of their immediate family; (iii) their partner or (iv) an organization that employs, or is about to employ, any of the above, has a financial interest in the Contractor. The Owner's officers, employees, or agents shall neither solicit nor accept gratuities, favors, or anything of monetary value from the Contractor or subcontractors.

(e) If the Owner finds after a notice and hearing that the Contractor, or any of the Contractor's agents or representatives, offered or gave gratuities (in the form of entertainment, gifts, or otherwise) to any official, employee, or agent of the Owner or EDA in an attempt to secure this Contract or favorable treatment in awarding, amending, or making any determinations related to the performance of this Contract, the Owner may, by written notice to the Contractor, terminate this Contract. The Owner may also pursue other rights and remedies that the law or this Contract

provides. However, the existence of the facts on which the Owner bases such findings shall be an issue and may be reviewed in proceedings under the dispute resolution provisions of this Contract.

(f) In the event this Contract is terminated as provided in paragraph (e) of this section, the Owner may pursue the same remedies against the Contractor as it could pursue in the event of a breach of this Contract by the Contractor. As a penalty, in addition to any other damages to which it may be entitled by law, the Owner may pursue exemplary damages in an amount (as determined by the Owner) which shall not be less than three nor more than ten times the costs the Contractor incurs in providing any such gratuities to any such officer or employee.

21. **RESTRICTIONS ON LOBBYING**

(a) This Contract, or subcontract is subject to section 319 of Public Law 101-121, which added section 1352, regarding lobbying restrictions, to chapter 13 of title 31 of the United States Code. The new section is explained in the common rule, 15 C.F.R. part 28 (55 FR 6736-6748, February 26, 1990). Each bidder under this Contract or subcontract is generally prohibited from using federal funds for lobbying the Executive or Legislative Branches of the Federal Government in connection with this EDA Award.

(b) **Contract Clause Threshold:** This Contract Clause regarding lobbying must be included in each bid for a contract or subcontract exceeding \$100,000 of federal funds at any tier under the EDA Award.

(c) **Certification and Disclosure:** Each bidder of a contract or subcontract exceeding \$100,000 of federal funds at any tier under the federal Award must file Form CD-512, *Certification Regarding Lobbying*, and, if applicable, Standard Form-LLL, *Disclosure of Lobbying Activities*, regarding the use of any nonfederal funds for lobbying. Certifications shall be retained by the Contractor or subcontractor at the next higher tier. All disclosure forms, however, shall be forwarded from tier to tier until received by the Recipient of the EDA Award, who shall forward all disclosure forms to EDA.

(d) **Continuing Disclosure Requirement:** Each Contractor or subcontractor that is subject to the Certification and Disclosure provision of this Contract Clause is required to file a disclosure form at the end of each calendar quarter in which there occurs any event that requires disclosure or that materially affects the accuracy of the information contained in any disclosure form previously filed by such person. Disclosure forms shall be forwarded from tier to tier until received by the Recipient of the EDA Award, who shall forward all disclosure forms to EDA.

(e) **Indian Tribes, Tribal Organizations, or Other Indian Organizations:** Indian tribes, tribal organizations, or any other Indian organizations, including Alaskan Native organizations, are excluded from the above lobbying restrictions and reporting requirements, but only with respect to expenditures that are by such tribes or organizations for lobbying activities permitted by other federal law. An Indian tribe or organization that is seeking an exclusion from Certification and Disclosure requirements must provide EDA with the citation of the provision or provisions of federal law upon which it relies to conduct lobbying activities that would otherwise

be subject to the prohibitions in and to the Certification and Disclosure requirements of section 319 of Public Law No. 101-121, preferably through an attorney's opinion. Note, also, that a non-Indian subrecipient, contractor, or subcontractor under an award to an Indian tribe, for example, is subject to the restrictions and reporting requirements.

22. **HISTORICAL AND ARCHAEOLOGICAL DATA PRESERVATION**

The Contractor agrees to facilitate the preservation and enhancement of structures and objects of historical, architectural or archaeological significance and when such items are found and/or unearthed during the course of project construction. Any excavation by the Contractor that uncovers an historical or archaeological artifact shall be immediately reported to the Owner and a representative of EDA. Construction shall be temporarily halted pending the notification process and further directions issued by EDA after consultation with the State Historic Preservation Officer (SHPO) for recovery of the items. See the National Historic Preservation Act of 1966 (80 Stat 915, 16 U.S.C. § 470) and Executive Order No. 11593 of May 31, 1971.

23. **CLEAN AIR AND WATER**

Applicable to Contracts in Excess of \$100,000

(a) **Definition.** "Facility" means any building, plant, installation, structure, mine, vessel, or other floating craft, location, or site of operations, owned, leased, or supervised by the Contractor or any subcontractor, used in the performance of the Contract or any subcontract. When a location or site of operations includes more than one building, plant, installation, or structure, the entire location or site shall be deemed a facility except when the Administrator, or a designee, of the United States Environmental Protection Agency (EPA) determines that independent facilities are collocated in one geographical area.

(b) In compliance with regulations issued by the EPA, 2 C.F.R. part 1532, pursuant to the Clean Air Act, as amended (42 U.S.C. § 7401 *et seq.*); the Federal Water Pollution Control Act, as amended (33 U.S.C. § 1251 *et seq.*); and Executive Order 11738, the Contractor agrees to:

- (1) Not utilize any facility in the performance of this contract or any subcontract which is listed on the EPA List of Violating Facilities pursuant to 2 C.F.R. part 1532 for the duration of time that the facility remains on the list;
- (2) Promptly notify the Owner if a facility the Contractor intends to use in the performance of this contract is on the EPA List of Violating Facilities or the Contractor knows that it has been recommended to be placed on the List;
- (3) Comply with all requirements of the Clean Air Act and the Federal Water Pollution Control Act, including the requirements of section 114 of the Clean Air Act and section 308 of the Federal Water Pollution Control Act, and all applicable clean air and clean water standards; and

(4) Include or cause to be included the provisions of this clause in every subcontract and take such action as EDA may direct as a means of enforcing such provisions.

24. **USE OF LEAD-BASED PAINTS ON RESIDENTIAL STRUCTURES**

(a) If the work under this Contract involves construction or rehabilitation of residential structures, the Contractor shall comply with the Lead-based Paint Poisoning Prevention Act (42 U.S.C. § 4831). The Contractor shall assure that paint used on the Project on applicable surfaces does not contain lead in excess of the percentages set forth in Paragraphs (a) and (b) of this section. In determining compliance with these standards, the lead content of the paint shall be measured on the basis of the total nonvolatile content of the paint or on the basis of an equivalent measure of lead in the dried film of paint already applied.

(1) For paint manufactured after June 22, 1977, paint may not contain lead in excess of 6 one-hundredths of 1 percent (.0006) lead by weight.

(2) For paint manufactured on or before June 22, 1977, paint may not contain lead in excess of five-tenths of 1 percent lead by weight.

(b) As a condition to receiving assistance under PWEDA, recipients shall assure that the restriction against the use of lead-based paint is included in all contracts and subcontracts involving the use of federal funds.

(c) **Definitions**

(1) “Applicable surfaces” are those exterior surfaces which are readily accessible to children under seven years of age.

(2) “Residential structures” means houses, apartments, or other structures intended for human habitation, including institutional structures where persons reside, which are accessible to children under seven years of age, such as day care centers, intermediate and extended care facilities, and certain community facilities.

25. **ENERGY EFFICIENCY**

The Contractor shall comply with all standards and policies relating to energy efficiency which are contained in the energy conservation plan issued in compliance with the Energy Policy and Conservation Act (Public L. No. 94-163) for the State in which the Work under the Contract is performed.

26. **ENVIRONMENTAL REQUIREMENTS**

When constructing a Project involving trenching and/or other related earth excavations, the Contractor shall comply with the following environmental constraints:

(1) **Wetlands.** When disposing of excess, spoil, or other construction materials on public or private property, the Contractor shall not fill in or otherwise convert wetlands.

(2) **Floodplains.** When disposing of excess, spoil, or other construction materials on public or private property, the Contractor shall not fill in or otherwise convert 100 year floodplain areas delineated on the latest Federal Emergency Management Agency (FEMA) Floodplain Maps, or other appropriate maps, i.e., alluvial soils on Natural Resource Conservation Service (NRCS) Soil Survey Maps.

(4) **Endangered Species.** The Contractor shall comply with the Endangered Species Act, which provides for the protection of endangered and/or threatened species and critical habitat. Should any evidence of the presence of endangered and/or threatened species or their critical habitat be brought to the attention of the Contractor, the Contractor will immediately report this evidence to the Owner and a representative of EDA. Construction shall be temporarily halted pending the notification process and further directions issued by EDA after consultation with the U.S. Fish and Wildlife Service.

27. **DEBARMENT, SUSPENSION, INELIGIBILITY, AND VOLUNTARY EXCLUSIONS**

As required by Executive Order 12549, *Debarment and Suspension*, and implemented at 2 C.F.R. part 1326, for prospective participants in lower tier covered transactions (except subcontracts for goods or services under the \$25,000 small purchase threshold unless the subrecipient will have a critical influence on or substantive control over the award), as defined at 2 C.F.R. part 1326.

(1) By entering into this Contract, and by further executing Form CD-512, the Contractor and subcontractors certify, that neither it nor its principals is presently debarred, suspended, proposed for debarment, declared ineligible, or voluntarily excluded from participation in this Contract by any federal department or agency.

(2) Where the Contractor or subcontractors are unable to certify to any of the statements in this certification, the Contractor or subcontractors shall attach an explanation to this bid.

See also 15 C.F.R. §§ 14.13 or 24.35, as applicable.

28. **EDA PROJECT SIGN**

The Contractor shall supply, erect, and maintain in good condition a Project sign according to the specifications provided by EDA. To the extent practical, the sign should be a free standing sign. Project signs shall not be located on public highway rights-of-way. Location and height of signs will be coordinated with the local agency responsible for highway or street safety in the Project area, if any possibility exists for obstructing vehicular traffic line of sight. Whenever the EDA site sign specifications conflict with State law or local ordinances, the EDA Regional Director will permit such conflicting specifications to be modified so as to comply with State law or local ordinance.

EDA PROJECT SIGN

The Contractor shall supply, erect, and maintain in good condition a project sign according to the specifications set forth below:

EDA SITE SIGN SPECIFICATIONS

Size: 4' x 8' x ¾"

Materials: Exterior grade/MDO plywood (APA rating A-B)

Supports: 4" x 4" x 12' posts with 2" x 4" cross branching

Erection: Posts shall be set a minimum of three feet deep in concrete footings that are at least 12" in diameter.

Paint: Outdoor enamel

Colors: Jet Black, Blue (PMS300), and Gold (PMS7406). Specifically, on white background the following will be placed:

The U. S. Department of Commerce seal in blue, black, and gold;

“EDA” in blue;

“U. S. DEPARTMENT OF COMMERCE ECONOMIC DEVELOPMENT
ADMINISTRATION” in black;

“In partnership with” in blue;

(Actual name of the) “Investment Recipient” in black;

“PUTTING AMERICA TO WORK” in blue;

“Barack Obama, President of the United States” in black.

Lettering: Specific fonts are named below; positioning will be as shown on the attached illustration.

“U. S. DEPARTMENT OF COMMERCE ECONOMIC DEVELOPMENT
ADMINISTRATION” use Bank Gothic Medium - **BANK GOTHIC MED**

“In partnership with” use Univers™ 55 Oblique - *Univers 55*

(Name of) “Investment Recipient” use Univers™ Extra Black 85 - **Univers 85**

“PUTTING AMERICA TO WORK” use Walkway Black - **Walkway**

“Barack Obama, President of the United States” use Univers™ 55 Oblique - *Univers 55*

Project signs will not be erected on public highway rights-of-way. If any possibility exists for obstruction to traffic line of sight, the location and height of the sign will be coordinated with the agency responsible for highway or street safety in the area.

The EDA Regional Director may permit modifications to these specifications if they conflict with state law or local ordinances.

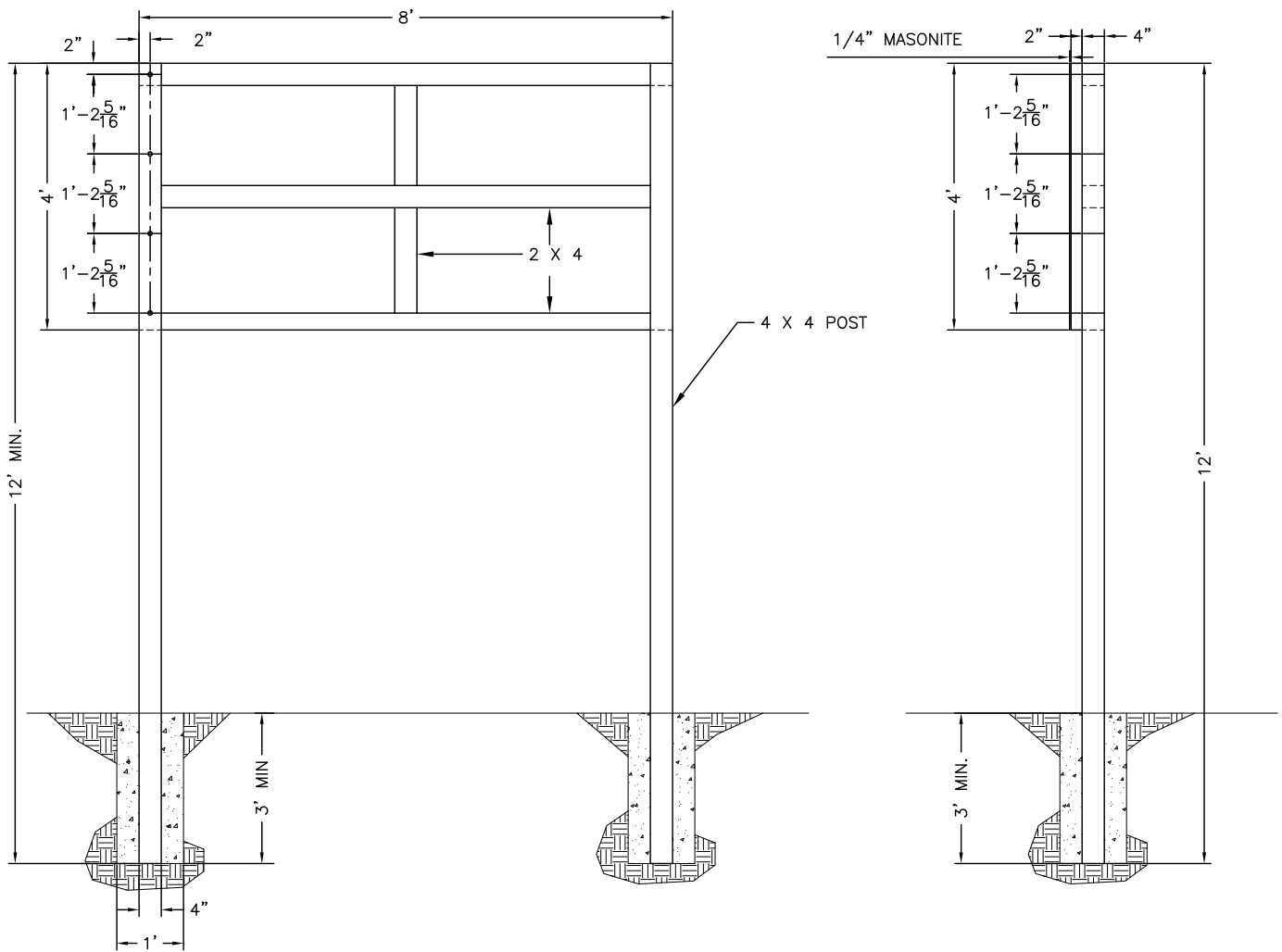

SIGN A
 MASONITE SIGN
 SCALE: 3/8" = 1'

PROJECT - SIGN A
ECONOMIC DEVELOPMENT ADMINISTRATION

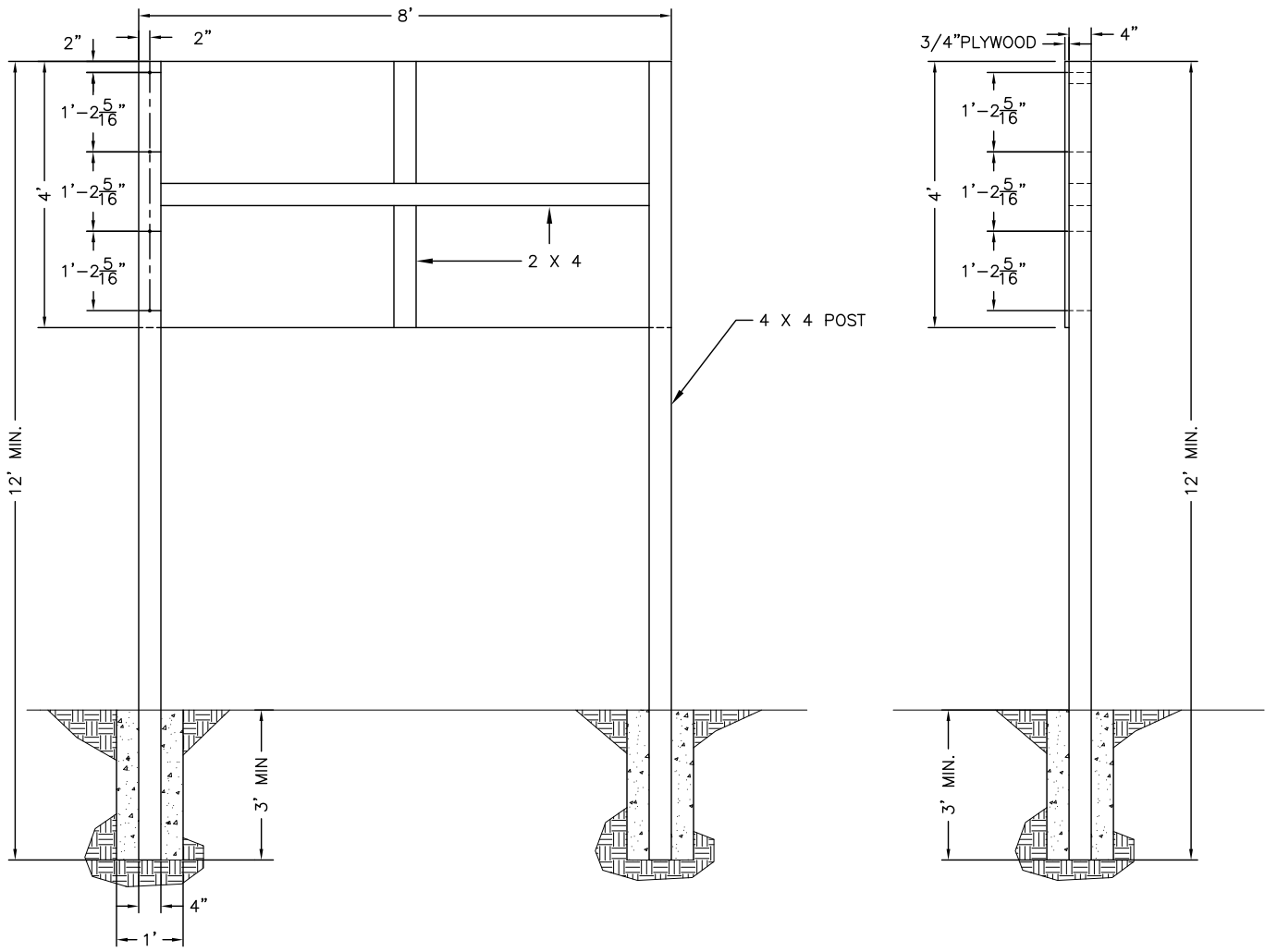

SIGN B
 PLYWOOD SIGN
 SCALE: 3/8" = 1'

PROJECT - SIGN B
ECONOMIC DEVELOPMENT ADMINISTRATION



EEDA

U.S. DEPARTMENT OF COMMERCE ECONOMIC DEVELOPMENT ADMINISTRATION

In partnership with

Recipient Name

PUTTING AMERICA TO WORK

Barack Obama, President of the United States

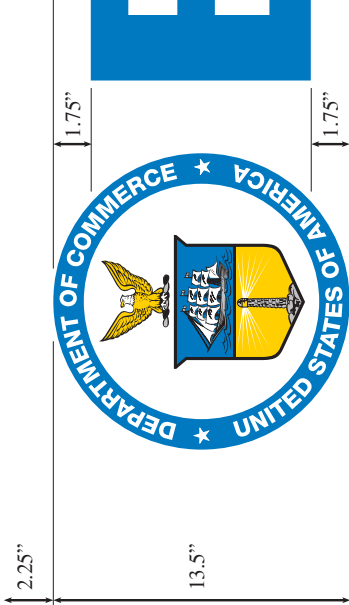

Black
 Blue= PMS300
 Gold= PMS7406

E D A

U.S. DEPARTMENT OF COMMERCE ECONOMIC DEVELOPMENT ADMINISTRATION

In partnership with

Recipient Name

PUTTING AMERICA TO WORK

Barack Obama, President of the United States

**NOTICE OF REQUIREMENTS FOR AFFIRMATIVE ACTION
TO ENSURE EQUAL EMPLOYMENT OPPORTUNITY
(EXECUTIVE ORDER 11246 AND 41 CFR PART 60-4)**

The following Notice shall be included in, and shall be a part of all solicitations for offers and bids on all Federal and federally assisted construction contracts or subcontracts in excess of \$10,000.

The Offeror's or Bidder's attention is called to the "Equal Opportunity Clause" and the "Standard Federal Equal Employment Opportunity Construction Contract Specifications" set forth herein.

The goals and timetables for minority and female participation, expressed in percentage terms for the Contractor's aggregate workforce in each trade on all construction work in the covered area, are as follows:

Timetables	Goals for minority participation for each trade	Goals for female participation for each trade
	16 %	6.9%

These goals are applicable to all the Contractor's construction work (whether or not it is Federal or federally assisted) performed in the covered area. If the contractor performs construction work in a geographical area located outside of the covered area, it shall apply the goals established for such geographical area where the work is actually performed. With regard to this second area, the contractor also is subject to the goals for both its federally involved and non federally involved construction.

The Contractor's compliance with the Executive Order and the regulations in 41 CFR Part 60-4 shall be based on its implementation of the Equal Opportunity Clause, specific affirmative action obligations required by the specifications set forth in 41 CFR 60-4.3(a), and its efforts to meet the goals. The hours of minority and female employment and training must be substantially uniform throughout the length of the contract, and in each trade and the contractor shall make a good faith effort to employ minorities and women evenly on each of its projects. The transfer of minority or female employees or trainees from Contractor to Contractor or from project to project for the sole purpose of meeting the Contractor's goals shall be a violation of the contract, the Executive Order, and the regulations in 41 CFR Part 60-4. Compliance with the goals will be measured against the total work hours performed.

The Contractor shall provide written notification to the Director of the Office of Federal Contract Compliance Programs within 10 working days of award of any construction subcontract in excess of \$10,000 at any tier for construction work under the contract resulting from this solicitation. The notification shall list the name, address and telephone number of the subcontractor; employer identification number of the subcontractor; estimated dollar amount of the subcontract; estimated starting and completion dates of the subcontract; and the geographical area in which the subcontract is to be performed. As used in this Notice, and in the contract resulting from this solicitation, the "covered area" is:

State of	<u>South Carolina</u>
County of	<u>Spartanburg</u>
City of	<u>Duncan</u>

CERTIFICATION REGARDING LOBBYING

Applicants should also review the instructions for certification included in the regulations before completing this form. Signature on this form provides for compliance with certification requirements under 15 CFR Part 28, "New Restrictions on Lobbying." The certifications shall be treated as a material representation of fact upon which reliance will be placed when the Department of Commerce determines to award the covered transaction, grant, or cooperative agreement.

LOBBYING

As required by Section 1352, Title 31 of the U.S. Code, and implemented at 15 CFR Part 28, for persons entering into a grant, cooperative agreement or contract over \$100,000 or a loan or loan guarantee over \$150,000 as defined at 15 CFR Part 28, Sections 28.105 and 28.110, the applicant certifies that to the best of his or her knowledge and belief, that:

(1) No Federal appropriated funds have been paid or will be paid, by or on behalf of the undersigned, to any person for influencing or attempting to influence an officer or employee of any agency, a Member of Congress in connection with the awarding of any Federal contract, the making of any Federal grant, the making of any Federal loan, the entering into of any cooperative agreement, and the extension, continuation, renewal, amendment, or modification of any Federal contract, grant, loan, or cooperative agreement.

(2) If any funds other than Federal appropriated funds have been paid or will be paid to any person for influencing or attempting to influence an officer or employee of any agency, a Member of Congress, an officer or employee of Congress, or an employee of a member of Congress in connection with this Federal contract, grant, loan, or cooperative agreement, the undersigned shall complete and submit Standard Form-LLL, "Disclosure Form to Report Lobbying," in accordance with its instructions.

(3) The undersigned shall require that the language of this certification be included in the award documents for all subawards at all tiers (including subcontracts, subgrants, and contracts under grants, loans, and cooperative agreements) and that all subrecipients shall certify and disclose accordingly.

This certification is a material representation of fact upon which reliance was placed when this transaction was made or entered into. Submission of this certification is a prerequisite for making or entering into this transaction imposed by section 1352, title 31, U.S. Code. Any person who fails to file the required certification shall be subject to a civil penalty of not less than \$10,000 and not more than \$100,000 for each such failure occurring on or before October 23, 1996, and of not less than \$11,000 and not more than \$110,000 for each such failure occurring after October 23, 1996.

Statement for Loan Guarantees and Loan Insurance

The undersigned states, to the best of his or her knowledge and belief, that:

In any funds have been paid or will be paid to any person for influencing or attempting to influence an officer or employee of any agency, a Member of Congress, an officer or employee of Congress, or an employee of a Member of Congress in connection with this commitment providing for the United States to insure or guarantee a loan, the undersigned shall complete and submit Standard Form-LLL, "Disclosure Form to Report Lobbying," in accordance with its instructions.

Submission of this statement is a prerequisite for making or entering into this transaction imposed by section 1352, title 31, U.S. Code. Any person who fails to file the required statement shall be subject to a civil penalty of not less than \$10,000 and not more than \$100,000 for each such failure occurring on or before October 23, 1996, and of not less than \$11,000 and not more than \$110,000 for each such failure occurring after October 23, 1996.

As the duly authorized representative of the applicant, I hereby certify that the applicant will comply with the above applicable certification.

NAME OF APPLICANT	AWARD NUMBER AND/OR PROJECT NAME
-------------------	----------------------------------

PRINTED NAME AND TITLE OF AUTHORIZED REPRESENTATIVE

SIGNATURE	DATE
-----------	------

General Decision Number: SC150036 05/22/2015 SC36

Superseded General Decision Number: SC20140036

State: South Carolina

Construction Type: Building

County: Spartanburg County in South Carolina.

BUILDING CONSTRUCTION PROJECTS (does not include single family homes or apartments up to and including 4 stories).

Note: Executive Order (EO) 13658 establishes an hourly minimum wage of \$10.10 for 2015 that applies to all contracts subject to the Davis-Bacon Act for which the solicitation is issued on or after January 1, 2015. If this contract is covered by the EO, the contractor must pay all workers in any classification listed on this wage determination at least \$10.10 (or the applicable wage rate listed on this wage determination, if it is higher) for all hours spent performing on the contract. The EO minimum wage rate will be adjusted annually. Additional information on contractor requirements and worker protections under the EO is available at www.dol.gov/whd/govcontracts.

Modification Number	Publication Date
0	01/02/2015
1	02/20/2015
2	05/22/2015

ELEC0379-010 12/29/2014

	Rates	Fringes
ELECTRICIAN.....	\$ 23.70	13%+6.45

Work from swinging scaffolds, boson chairs, or raw structural steel: \$1.00 per hour additional.

* IRON0848-006 12/01/2014

	Rates	Fringes
IRONWORKER, STRUCTURAL.....	\$ 23.00	12.00

PLUM0421-005 07/01/2013

	Rates	Fringes
PIPEFITTER.....	\$ 24.85	9.65

SUSC2011-025 08/31/2011

	Rates	Fringes
BRICKLAYER.....	\$ 17.50	0.67
CARPENTER (Drywall Hanging Only).....	\$ 16.32	1.50
CARPENTER (Form Work Only).....	\$ 15.53	1.76
CARPENTER, Excludes Drywall Hanging, and Form Work.....	\$ 14.75	0.92
CEMENT MASON/CONCRETE FINISHER...	\$ 14.10	0.00
HVAC MECHANIC (HVAC Duct Installation Only).....	\$ 19.11	0.00
LABORER: Common or General.....	\$ 10.52	0.66
LABORER: Landscape.....	\$ 9.45	0.49
LABORER: Mason Tender-Brick/Concrete/Cement/S tone.....	\$ 10.88	0.00

LABORER: Pipelayer.....	\$ 14.69	2.08
OPERATOR: Backhoe/Excavator/Trackhoe.....	\$ 16.05	1.96
OPERATOR: Bulldozer.....	\$ 17.07	2.65
OPERATOR: Crane.....	\$ 19.39	2.02
OPERATOR: Grader/Blade.....	\$ 17.50	1.78
OPERATOR: Loader.....	\$ 11.64	1.03
PAINTER: Brush, Roller and Spray.....	\$ 12.36	0.00
PLUMBER.....	\$ 19.21	4.56
ROOFER.....	\$ 12.11	0.00
TRUCK DRIVER.....	\$ 14.05	3.18

WELDERS - Receive rate prescribed for craft performing operation to which welding is incidental.

=====
Unlisted classifications needed for work not included within the scope of the classifications listed may be added after award only as provided in the labor standards contract clauses (29CFR 5.5 (a) (1) (ii)).

The body of each wage determination lists the classification and wage rates that have been found to be prevailing for the cited type(s) of construction in the area covered by the wage determination. The classifications are listed in alphabetical order of "identifiers" that indicate whether the particular rate is a union rate (current union negotiated rate for local), a survey rate (weighted average rate) or a union average rate (weighted union average rate).

Union Rate Identifiers

A four letter classification abbreviation identifier enclosed in dotted lines beginning with characters other than "SU" or "UAVG" denotes that the union classification and rate were prevailing for that classification in the survey. Example: PLUM0198-005 07/01/2014. PLUM is an abbreviation identifier of the union which prevailed in the survey for this classification, which in this example would be Plumbers. 0198 indicates the local union number or district council number where applicable, i.e., Plumbers Local 0198. The next number, 005 in the example, is an internal number used in processing the wage determination. 07/01/2014 is the effective date of the most current negotiated rate, which in this example is July 1, 2014.

Union prevailing wage rates are updated to reflect all rate changes in the collective bargaining agreement (CBA) governing this classification and rate.

Survey Rate Identifiers

Classifications listed under the "SU" identifier indicate that no one rate prevailed for this classification in the survey and the published rate is derived by computing a weighted average rate based on all the rates reported in the survey for that classification. As this weighted average rate includes all rates reported in the survey, it may include both union and non-union rates. Example: SULA2012-007 5/13/2014. SU indicates the rates are survey rates based on a weighted average calculation of rates and are not majority rates. LA indicates the State of Louisiana. 2012 is the year of survey on which these classifications and rates are based. The next number, 007 in the example, is an internal number used in producing the

wage determination. 5/13/2014 indicates the survey completion date for the classifications and rates under that identifier.

Survey wage rates are not updated and remain in effect until a new survey is conducted.

Union Average Rate Identifiers

Classification(s) listed under the UAVG identifier indicate that no single majority rate prevailed for those classifications; however, 100% of the data reported for the classifications was union data. EXAMPLE: UAVG-OH-0010 08/29/2014. UAVG indicates that the rate is a weighted union average rate. OH indicates the state. The next number, 0010 in the example, is an internal number used in producing the wage determination. 08/29/2014 indicates the survey completion date for the classifications and rates under that identifier.

A UAVG rate will be updated once a year, usually in January of each year, to reflect a weighted average of the current negotiated/CBA rate of the union locals from which the rate is based.

WAGE DETERMINATION APPEALS PROCESS

1.) Has there been an initial decision in the matter? This can be:

- * an existing published wage determination
- * a survey underlying a wage determination
- * a Wage and Hour Division letter setting forth a position on a wage determination matter
- * a conformance (additional classification and rate) ruling

On survey related matters, initial contact, including requests for summaries of surveys, should be with the Wage and Hour Regional Office for the area in which the survey was conducted because those Regional Offices have responsibility for the Davis-Bacon survey program. If the response from this initial contact is not satisfactory, then the process described in 2.) and 3.) should be followed.

With regard to any other matter not yet ripe for the formal process described here, initial contact should be with the Branch of Construction Wage Determinations. Write to:

Branch of Construction Wage Determinations
Wage and Hour Division
U.S. Department of Labor
200 Constitution Avenue, N.W.
Washington, DC 20210

2.) If the answer to the question in 1.) is yes, then an interested party (those affected by the action) can request review and reconsideration from the Wage and Hour Administrator (See 29 CFR Part 1.8 and 29 CFR Part 7). Write to:

Wage and Hour Administrator
U.S. Department of Labor
200 Constitution Avenue, N.W.
Washington, DC 20210

The request should be accompanied by a full statement of the interested party's position and by any information (wage payment data, project description, area practice material, etc.) that the requestor considers relevant to the issue.

3.) If the decision of the Administrator is not favorable, an interested party may appeal directly to the Administrative Review Board (formerly the Wage Appeals Board). Write to:

Administrative Review Board
U.S. Department of Labor
200 Constitution Avenue, N.W.
Washington, DC 20210

4.) All decisions by the Administrative Review Board are final.

=====
END OF GENERAL DECISION

BUY AMERICAN CLAUSE

"Contractors are hereby notified that they are encouraged, to the greatest extent practicable, to purchase American-made equipment and products with funding provided under this award".

SECTION 011000 - SUMMARY

PART 1 - GENERAL

1.1 RELATED DOCUMENTS

- A. Drawings and general provisions of the Contract, including General and Supplementary Conditions and other Division 01 Specification Sections, apply to this Section.

1.2 SUMMARY

- A. Section Includes:
 - 1. Work restrictions.
 - 2. Specification and drawing conventions.

1.3 WORK BY OWNER

- A. General: Cooperate fully with Owner so work may be carried out smoothly, without interfering with or delaying work under this Contract or work by Owner. Coordinate the Work of this Contract with work performed by Owner.
- B. Concurrent Work: Owner will perform the following construction operations at Project site. Those operations will be conducted simultaneously with work under this Contract.

1.4 WORK UNDER SEPARATE CONTRACTS

- A. General: Cooperate fully with separate contractors so work on those contracts may be carried out smoothly, without interfering with or delaying work under this Contract or other contracts. Coordinate the Work of this Contract with work performed under separate contracts.
- B. Subsequent Work: Owner will award separate contract(s) for the following additional work to be performed at site following Substantial Completion. Completion of that work will depend on successful completion of preparatory work under this Contract.

1.5 ACCESS TO SITE

- A. General: Contractor shall have limited use of Project site for construction operations as indicated on Drawings by the Contract limits and as indicated by requirements of this Section.
- B. Use of Site: Limit use of Project site to work in areas within the Contract limits indicated. Do not disturb portions of Project site beyond areas in which the Work is indicated.
 - 1. Driveways, Walkways and Entrances: Keep driveways and entrances serving premises clear and available to Owner, Owner's employees, and emergency vehicles at all times. Do not use these areas for parking or storage of materials.
 - a. Schedule deliveries to minimize use of driveways and entrances by construction operations.
 - b. Schedule deliveries to minimize space and time requirements for storage of materials and equipment on-site.

- C. Condition of Existing Building: Maintain portions of existing building affected by construction operations in a weathertight condition throughout construction period. Repair damage caused by construction operations.

1.6 COORDINATION WITH OCCUPANTS

- A. Partial Owner Occupancy: Owner will occupy the premises during entire construction period, with the exception of areas under construction. Cooperate with Owner during construction operations to minimize conflicts and facilitate Owner usage. Perform the Work so as not to interfere with Owner's operations. Maintain existing exits unless otherwise indicated.
 - 1. Provide not less than 72 hours' notice to Owner of activities that will affect Owner's operations.

1.7 WORK RESTRICTIONS

- A. Work Restrictions, General: Comply with restrictions on construction operations.
 - 1. Comply with limitations on use of public streets and with other requirements of authorities having jurisdiction.
- B. On-Site Work Hours: Limit work in the existing building to normal business working hours of 6:30 a.m. to 6:00 p.m., Monday through Friday, unless otherwise indicated.
 - 1. Weekend Hours: Saturdays from 6:00 a.m. until 6:00 p.m. No work on Sundays unless permission is received from Owner..
 - 2. Hours for Utility Shutdowns: Owner and local jurisdiction to be given 48 hours advance notice. City or county may require additional time, depending on duration of shutdown. .
- C. Nonsmoking Building: Smoking is not permitted within the building or within 25 feet of entrances, operable windows, or outdoor-air intakes.
- D. Controlled Substances: Use of tobacco products and other controlled substances on Project site is not permitted.

1.8 SPECIFICATION AND DRAWING CONVENTIONS

- A. Specification Content: The Specifications use certain conventions for the style of language and the intended meaning of certain terms, words, and phrases when used in particular situations. These conventions are as follows:
 - 1. Imperative mood and streamlined language are generally used in the Specifications. The words "shall," "shall be," or "shall comply with," depending on the context, are implied where a colon (:) is used within a sentence or phrase.
 - 2. Specification requirements are to be performed by Contractor unless specifically stated otherwise.
- B. Division 01 General Requirements: Requirements of Sections in Division 01 apply to the Work of all Sections in the Specifications.
- C. Drawing Coordination: Requirements for materials and products identified on Drawings are described in detail in the Specifications. One or more of the following are used on Drawings to identify materials and products:

1. Terminology: Materials and products are identified by the typical generic terms used in the individual Specifications Sections.
2. Abbreviations: Materials and products are identified by abbreviations and scheduled on Drawings.

PART 2 - PRODUCTS (Not Used)

PART 3 - EXECUTION (Not Used)

END OF SECTION 011000

SECTION 012300 - ALTERNATES

PART 1 - GENERAL

1.1 RELATED DOCUMENTS

- A. Drawings and general provisions of the Contract, including General and Supplementary Conditions and other Division 01 Specification Sections, apply to this Section.

1.2 SUMMARY

- A. Section includes administrative and procedural requirements for alternates.

1.3 DEFINITIONS

- A. Alternate: An amount proposed by bidders and stated on the Bid Form for certain work defined in the bidding requirements that may be added to or deducted from the base bid amount if Owner decides to accept a corresponding change either in the amount of construction to be completed or in the products, materials, equipment, systems, or installation methods described in the Contract Documents.
 - 1. Alternates described in this Section are part of the Work only if enumerated in the Agreement.
 - 2. The cost or credit for each alternate is the net addition to or deduction from the Contract Sum to incorporate alternate into the Work. No other adjustments are made to the Contract Sum.

1.4 PROCEDURES

- A. Coordination: Revise or adjust affected adjacent work as necessary to completely integrate work of the alternate into Project.
 - 1. Include as part of each alternate, miscellaneous devices, accessory objects, and similar items incidental to or required for a complete installation whether or not indicated as part of alternate.
- B. Execute accepted alternates under the same conditions as other work of the Contract.
- C. Schedule: A schedule of alternates is included at the end of this Section. Specification Sections referenced in schedule contain requirements for materials necessary to achieve the work described under each alternate.

PART 2 - PRODUCTS (Not Used)

PART 3 - EXECUTION

3.1 SCHEDULE OF ALTERNATES

A. Alternate No. 1: Lay-in Metal Ceiling Panels

1. Base Bid: Provide in the base bid acoustical lay-in ceiling panels (ACP-1) in floating ceiling clouds in Collaboration 119 and as specified in Section 095113 Acoustical Panel Ceilings.
2. Add Alternate: Provide in an Add Alternate lay-in metal ceiling panels (ACP-2) in floating ceiling clouds in Collaboration 119 and as specified in Section 095113 Acoustical Panel Ceilings.

B. Alternate No. 2: Metal ACM Wall Panels

1. Base Bid: Provide in the base bid painted gypsum board in lieu of Metal ACM Wall Panels shown on drawings.
2. Add Alternate: Provide in an Add Alternate Metal ACM Wall Panels as shown on drawings and as specified in Section 098400 Metal Wall Systems.

C. Alternate No. 3: Upgrading Existing Toilets 133 & 134

1. Base Bid: No work in Toilets 133 & 134 is to be included in the base bid.
2. Add Alternate: Provide in an Add Alternate all work involved with upgrading Existing Toilets 133 & 134 as shown on drawings.

END OF SECTION 012300

SECTION 012900 - PAYMENT PROCEDURES

PART 1 - GENERAL

1.1 RELATED DOCUMENTS

- A. Drawings and general provisions of the Contract, including General and Supplementary Conditions and other Division 01 Specification Sections, apply to this Section.

1.2 SUMMARY

- A. Section includes administrative and procedural requirements necessary to prepare and process Applications for Payment.

- 1. Division 01 Section "Closeout Procedures" for requirements prior to final payment.

1.3 DEFINITIONS

- A. Schedule of Values: A statement furnished by Contractor allocating portions of the Contract Sum to various portions of the Work and used as the basis for reviewing Contractor's Applications for Payment.

1.4 SCHEDULE OF VALUES

- A. Coordination: Coordinate preparation of the schedule of values with preparation of Contractor's construction schedule.

- 1. Coordinate line items in the schedule of values with other required administrative forms and schedules, including the following:

- a. Application for Payment forms with continuation sheets.
- b. Submittal schedule.
- c. Items required to be indicated as separate activities in Contractor's construction schedule.

- 2. Submit the schedule of values to Architect at earliest possible date, but no later than seven days before the date scheduled for submittal of initial Applications for Payment.

- 3. Subschedules for Separate Elements of Work: Where the Contractor's construction schedule defines separate elements of the Work, provide subschedules showing values coordinated with each element.

- B. Format and Content: Use Project Manual table of contents as a guide to establish line items for the schedule of values. Provide at least one line item for each Specification Section.

- 1. Identification: Include the following Project identification on the schedule of values:

- a. Project name and location.
- b. Name of Architect.
- c. Architect's project number.
- d. Contractor's name and address.
- e. Date of submittal.

2. Arrange schedule of values consistent with format of AIA Document G703.
3. Provide a breakdown of the Contract Sum in enough detail to facilitate continued evaluation of Applications for Payment and progress reports. Coordinate with Project Manual table of contents. Provide multiple line items for principal subcontract amounts in excess of five percent of the Contract Sum.
4. Round amounts to nearest whole dollar; total shall equal the Contract Sum.
5. Provide a separate line item in the schedule of values for each part of the Work where Applications for Payment may include materials or equipment purchased or fabricated and stored, but not yet installed.
 - a. Differentiate between items stored on-site and items stored off-site. If required, include evidence of insurance.
6. Provide separate line items in the schedule of values for initial cost of materials, for each subsequent stage of completion, and for total installed value of that part of the Work.
7. Allowances: Provide a separate line item in the schedule of values for each allowance. Show line-item value of unit-cost allowances, as a product of the unit cost, multiplied by measured quantity. Use information indicated in the Contract Documents to determine quantities.
8. Each item in the schedule of values and Applications for Payment shall be complete. Include total cost and proportionate share of general overhead and profit for each item.
 - a. Temporary facilities and other major cost items that are not direct cost of actual work-in-place may be shown either as separate line items in the schedule of values or distributed as general overhead expense, at Contractor's option.
9. Schedule Updating: Update and resubmit the schedule of values before the next Applications for Payment when Change Orders or Construction Change Directives result in a change in the Contract Sum.

1.5 APPLICATIONS FOR PAYMENT

- A. Each Application for Payment following the initial Application for Payment shall be consistent with previous applications and payments as certified by Architect and paid for by Owner.
 1. Initial Application for Payment, Application for Payment at time of Substantial Completion, and final Application for Payment involve additional requirements.
- B. Payment Application Times: The date for each progress payment is indicated in the Agreement between Owner and Contractor. The period of construction work covered by each Application for Payment is the period indicated in the Agreement.
- C. Application for Payment Forms: Use AIA Document G702 and AIA Document G703 as form for Applications for Payment.
- D. Application Preparation: Complete every entry on form. Notarize and execute by a person authorized to sign legal documents on behalf of Contractor. Architect will return incomplete applications without action.
 1. Entries shall match data on the schedule of values and Contractor's construction schedule. Use updated schedules if revisions were made.
 2. Include amounts for work completed following previous Application for Payment, whether or not payment has been received. Include only amounts for work completed at time of Application for Payment.
 3. Include amounts of Change Orders and Construction Change Directives issued before last day of construction period covered by application.

- E. **Stored Materials:** Include in Application for Payment amounts applied for materials or equipment purchased or fabricated and stored, but not yet installed. Differentiate between items stored on-site and items stored off-site.
1. Provide certificate of insurance, evidence of transfer of title to Owner, and consent of surety to payment, for stored materials.
 2. Provide supporting documentation that verifies amount requested, such as paid invoices. Match amount requested with amounts indicated on documentation; do not include overhead and profit on stored materials.
 3. Provide summary documentation for stored materials indicating the following:
 - a. Value of materials previously stored and remaining stored as of date of previous Applications for Payment.
 - b. Value of previously stored materials put in place after date of previous Application for Payment and on or before date of current Application for Payment.
 - c. Value of materials stored since date of previous Application for Payment and remaining stored as of date of current Application for Payment.
- F. **Transmittal:** Submit four signed and notarized original copies of each Application for Payment to by a method ensuring receipt within 24 hours. One copy shall include waivers of lien and similar attachments if required.
- G. **Waivers of Mechanic's Lien:** With each Application for Payment, submit waivers of mechanic's liens from subcontractors, sub-subcontractors, and suppliers for construction period covered by the previous application.
1. Submit partial waivers on each item for amount requested in previous application, after deduction for retainage, on each item.
 2. When an application shows completion of an item, submit conditional final or full waivers.
 3. Submit final Application for Payment with or preceded by conditional final waivers from every entity involved with performance of the Work covered by the application who is lawfully entitled to a lien.
- H. **Initial Application for Payment:** Administrative actions and submittals that must precede or coincide with submittal of first Application for Payment include the following:
1. List of subcontractors.
 2. Schedule of values.
 3. Contractor's construction schedule (preliminary if not final). Final required with second application.
 4. Schedule of unit prices.
 5. Submittal schedule (preliminary if not final). Final required with second application.
 6. List of Contractor's staff assignments.
 7. List of Contractor's principal consultants.
 8. Copies of building permits.
 9. Initial progress report.
 10. Report of preconstruction conference.
- I. **Application for Payment at Substantial Completion:** After Architect issues the Certificate of Substantial Completion, submit an Application for Payment showing 100 percent completion for portion of the Work claimed as substantially complete.
1. Include documentation supporting claim that the Work is substantially complete and a statement showing an accounting of changes to the Contract Sum.
 2. This application shall reflect Certificate(s) of Substantial Completion issued previously for Owner occupancy of designated portions of the Work.
- J. **Final Payment Application:** After completing Project closeout requirements, submit final Application for Payment with releases and supporting documentation not previously submitted and accepted, including, but not limited, to the following:

1. Evidence of completion of Project closeout requirements.
2. Insurance certificates for products and completed operations where required and proof that taxes, fees, and similar obligations were paid.
3. Updated final statement, accounting for final changes to the Contract Sum.
4. AIA Document G706, "Contractor's Affidavit of Payment of Debts and Claims."
5. AIA Document G706A, "Contractor's Affidavit of Release of Liens."
6. AIA Document G707, "Consent of Surety to Final Payment."
7. Evidence that claims have been settled.
8. Final liquidated damages settlement statement.

PART 2 - PRODUCTS (Not Used)

PART 3 - EXECUTION (Not Used)

END OF SECTION 012900

SECTION 013100 - PROJECT MANAGEMENT AND COORDINATION

PART 1 - GENERAL

1.1 RELATED DOCUMENTS

- A. Drawings and general provisions of the Contract, including General and Supplementary Conditions and other Division 01 Specification Sections, apply to this Section.

1.2 SUMMARY

- A. Section includes administrative provisions for coordinating construction operations on Project including, but not limited to, the following:
 - 1. General coordination procedures.
 - 2. Coordination drawings.
 - 3. Requests for Information (RFIs).
 - 4. Project meetings.

1.3 DEFINITIONS

- A. RFI: Request from Owner, Architect, or Contractor seeking information required by or clarifications of the Contract Documents.

1.4 INFORMATIONAL SUBMITTALS

- A. Subcontract List: Prepare a written summary identifying individuals or firms proposed for each portion of the Work, including those who are to furnish products or equipment fabricated to a special design. Include the following information in tabular form:
 - 1. Name, address, and telephone number of entity performing subcontract or supplying products.
 - 2. Number and title of related Specification Section(s) covered by subcontract.
 - 3. Drawing number and detail references, as appropriate, covered by subcontract.
- B. Key Personnel Names: Within 15 days of starting construction operations, submit a list of key personnel assignments, including superintendent and other personnel in attendance at Project site. Identify individuals and their duties and responsibilities; list addresses and telephone numbers, including home, office, and cellular telephone numbers and e-mail addresses. Provide names, addresses, and telephone numbers of individuals assigned as alternates in the absence of individuals assigned to Project.
 - 1. Post copies of list in project meeting room, in temporary field office. Keep list current at all times.

1.5 GENERAL COORDINATION PROCEDURES

- A. Coordination: Coordinate construction operations included in different Sections of the Specifications to ensure efficient and orderly installation of each part of the Work. Coordinate construction operations, included in different Sections, that depend on each other for proper installation, connection, and operation.

1. Schedule construction operations in sequence required to obtain the best results where installation of one part of the Work depends on installation of other components, before or after its own installation.
 2. Coordinate installation of different components to ensure maximum performance and accessibility for required maintenance, service, and repair.
 3. Make adequate provisions to accommodate items scheduled for later installation.
- B. Prepare memoranda for distribution to each party involved, outlining special procedures required for coordination. Include such items as required notices, reports, and list of attendees at meetings.
1. Prepare similar memoranda for Owner and separate contractors if coordination of their Work is required.
- C. Conservation: Coordinate construction activities to ensure that operations are carried out with consideration given to conservation of energy, water, and materials. Coordinate use of temporary utilities to minimize waste.

1.6 COORDINATION DRAWINGS

- A. Coordination Drawings, General: Prepare coordination drawings according to requirements in individual Sections, and additionally where installation is not completely shown on Shop Drawings, where limited space availability necessitates coordination, or if coordination is required to facilitate integration of products and materials fabricated or installed by more than one entity.
1. Content: Project-specific information, drawn accurately to a scale large enough to indicate and resolve conflicts. Do not base coordination drawings on standard printed data. Include the following information, as applicable:
 - a. Use applicable Drawings as a basis for preparation of coordination drawings. Prepare sections, elevations, and details as needed to describe relationship of various systems and components.
 - b. Indicate functional and spatial relationships of components of architectural, structural, civil, mechanical, and electrical systems.
 - c. Indicate space requirements for routine maintenance and for anticipated replacement of components during the life of the installation.
 - d. Show location and size of access doors required for access to concealed dampers, valves, and other controls.
 - e. Indicate required installation sequences.
 - f. Indicate dimensions shown on the Drawings. Specifically note dimensions that appear to be in conflict with submitted equipment and minimum clearance requirements. Provide alternate sketches to Architect indicating proposed resolution of such conflicts. Minor dimension changes and difficult installations will not be considered changes to the Contract.

1.7 REQUESTS FOR INFORMATION (RFIs)

- A. General: Immediately on discovery of the need for additional information or interpretation of the Contract Documents, Contractor shall prepare and submit an RFI in the form specified.
1. Architect will return RFIs submitted to Architect by other entities controlled by Contractor with no response.
 2. Coordinate and submit RFIs in a prompt manner so as to avoid delays in Contractor's work or work of subcontractors.
- B. Content of the RFI: Include a detailed, legible description of item needing information or interpretation and the following:

1. Project name.
 2. Project number.
 3. Date.
 4. Name of Contractor.
 5. Name of Architect.
 6. RFI number, numbered sequentially.
 7. RFI subject.
 8. Specification Section number and title and related paragraphs, as appropriate.
 9. Drawing number and detail references, as appropriate.
 10. Field dimensions and conditions, as appropriate.
 11. Contractor's suggested resolution. If Contractor's suggested resolution impacts the Contract Time or the Contract Sum, Contractor shall state impact in the RFI.
 12. Contractor's signature.
 13. Attachments: Include sketches, descriptions, measurements, photos, Product Data, Shop Drawings, coordination drawings, and other information necessary to fully describe items needing interpretation.
 - a. Include dimensions, thicknesses, structural grid references, and details of affected materials, assemblies, and attachments on attached sketches.
- C. RFI Forms: Software-generated form with substantially the same content as indicated above, acceptable to Architect.
1. Attachments shall be electronic files in Adobe Acrobat PDF format.
- D. Architect's Action: Architect will review each RFI, determine action required, and respond. Allow seven working days for Architect's response for each RFI. RFIs received by Architect after 1:00 p.m. will be considered as received the following working day.
1. The following Contractor-generated RFIs will be returned without action:
 - a. Requests for approval of submittals.
 - b. Requests for approval of substitutions.
 - c. Requests for approval of Contractor's means and methods.
 - d. Requests for coordination information already indicated in the Contract Documents.
 - e. Requests for adjustments in the Contract Time or the Contract Sum.
 - f. Requests for interpretation of Architect's actions on submittals.
 - g. Incomplete RFIs or inaccurately prepared RFIs.
 2. Architect's action may include a request for additional information, in which case Architect's time for response will date from time of receipt of additional information.
 3. Architect's action on RFIs that may result in a change to the Contract Time or the Contract Sum may be eligible for Contractor to submit Change Proposal according to Division 01 Section "Contract Modification Procedures."
 - a. If Contractor believes the RFI response warrants change in the Contract Time or the Contract Sum, notify Architect in writing within seven days of receipt of the RFI response.
- E. RFI Log: Prepare, maintain, and submit a tabular log of RFIs organized by the RFI number. Submit log weekly. Software log with not less than the following:
1. Project name.
 2. Name and address of Contractor.
 3. Name and address of Architect.
 4. RFI number including RFIs that were returned without action or withdrawn.
 5. RFI description.
 6. Date the RFI was submitted.
 7. Date Architect's response was received.

- F. On receipt of Architect's action, update the RFI log and immediately distribute the RFI response to affected parties. Review response and notify Architect within seven days if Contractor disagrees with response.
 - 1. Identification of related Minor Change in the Work, Construction Change Directive, and Proposal Request, as appropriate.

 - G. Frivolous RFIs: Contractor shall consult the contract documents for project information before issuing an RFI. Architect shall be compensated for time spent answering frivolous RFIs where the information requested is already contained in the contract documents.
- 1.8 PROJECT MEETINGS
- A. General: Schedule and conduct meetings and conferences at Project site unless otherwise indicated.
 - 1. Attendees: Inform participants and others involved, and individuals whose presence is required, of date and time of each meeting. Notify Owner and Architect of scheduled meeting dates and times.
 - 2. Agenda: Prepare the meeting agenda. Distribute the agenda to all invited attendees.
 - 3. Minutes: Entity responsible for conducting meeting will record significant discussions and agreements achieved. Distribute the meeting minutes to everyone concerned, including Owner and Architect, within three days of the meeting.

 - B. Preconstruction Conference: Architect will schedule and conduct a preconstruction conference before starting construction, at a time convenient to Owner and Architect, but no later than 15 days after execution of the Agreement.
 - 1. Attendees: Authorized representatives of Owner Architect, and their consultants; Contractor and its superintendent; major subcontractors; suppliers; and other concerned parties shall attend the conference. Participants at the conference shall be familiar with Project and authorized to conclude matters relating to the Work.
 - 2. Agenda: Discuss items of significance that could affect progress, including the following:
 - a. Tentative construction schedule.
 - b. Critical work sequencing and long-lead items.
 - c. Designation of key personnel and their duties.
 - d. Lines of communications.
 - e. Procedures for processing field decisions and Change Orders.
 - f. Procedures for RFIs.
 - g. Procedures for testing and inspecting.
 - h. Procedures for processing Applications for Payment.
 - i. Distribution of the Contract Documents.
 - j. Submittal procedures.
 - k. Preparation of record documents.
 - l. Use of the premises and existing building.
 - m. Work restrictions.
 - n. Working hours.
 - o. Owner's occupancy requirements.
 - p. Responsibility for temporary facilities and controls.
 - q. Procedures for moisture and mold control.
 - r. Procedures for disruptions and shutdowns.
 - s. Construction waste management and recycling.
 - t. Parking availability.
 - u. Office, work, and storage areas.
 - v. Equipment deliveries and priorities.
 - w. First aid.
 - x. Security.
 - y. Progress cleaning.

3. Minutes: Entity responsible for conducting meeting will record and distribute meeting minutes.
- C. Preinstallation Conferences: Conduct a preinstallation conference at Project site before each construction activity that requires coordination with other construction.
1. Attendees: Installer and representatives of manufacturers and fabricators involved in or affected by the installation and its coordination or integration with other materials and installations that have preceded or will follow, shall attend the meeting. Advise Architect of scheduled meeting dates.
 2. Agenda: Review progress of other construction activities and preparations for the particular activity under consideration, including requirements for the following:
 - a. Contract Documents.
 - b. Options.
 - c. Related RFIs.
 - d. Related Change Orders.
 - e. Possible conflicts.
 - f. Compatibility requirements.
 - g. Time schedules.
 - h. Weather limitations.
 - i. Manufacturer's written instructions.
 - j. Warranty requirements.
 - k. Compatibility of materials.
 - l. Acceptability of substrates.
 - m. Temporary facilities and controls.
 - n. Space and access limitations.
 - o. Regulations of authorities having jurisdiction.
 - p. Testing and inspecting requirements.
 - q. Installation procedures.
 - r. Coordination with other work.
 - s. Required performance results.
 - t. Protection of adjacent work.
 - u. Protection of construction and personnel.
 3. Record significant conference discussions, agreements, and disagreements, including required corrective measures and actions.
 4. Reporting: Distribute minutes of the meeting to each party present and to other parties requiring information.
 5. Do not proceed with installation if the conference cannot be successfully concluded. Initiate whatever actions are necessary to resolve impediments to performance of the Work and reconvene the conference at earliest feasible date.
- D. Progress Meetings: progress meetings at weekly intervals.
1. Coordinate dates of meetings with preparation of payment requests.
 2. Attendees: In addition to representatives of Owner and Architect, each contractor, subcontractor, supplier, and other entity concerned with current progress or involved in planning, coordination, or performance of future activities shall be represented at these meetings. All participants at the meeting shall be familiar with Project and authorized to conclude matters relating to the Work.
 3. Agenda: Review and correct or approve minutes of previous progress meeting. Review other items of significance that could affect progress. Include topics for discussion as appropriate to status of Project.

- a. Contractor's Construction Schedule: Review progress since the last meeting. Determine whether each activity is on time, ahead of schedule, or behind schedule, in relation to Contractor's construction schedule. Determine how construction behind schedule will be expedited; secure commitments from parties involved to do so. Discuss whether schedule revisions are required to ensure that current and subsequent activities will be completed within the Contract Time.
 - 1) Review schedule for next period.
 - b. Review present and future needs of each entity present, including the following:
 - 1) Interface requirements.
 - 2) Sequence of operations.
 - 3) Status of submittals.
 - 4) Progress cleaning.
 - 5) Quality and work standards.
 - 6) Field observations.
 - 7) Status of RFIs.
 - 8) Status of Change Orders.
4. Minutes: Entity responsible for conducting the meeting will record and distribute the meeting minutes to each party present and to parties requiring information.
- a. Schedule Updating: Revise Contractor's construction schedule after each progress meeting where revisions to the schedule have been made or recognized. Issue revised schedule concurrently with the report of each meeting.

PART 2 - PRODUCTS (Not Used)

PART 3 - EXECUTION (Not Used)

END OF SECTION 013100

SECTION 013300 - SUBMITTAL PROCEDURES

PART 1 - GENERAL

1.1 RELATED DOCUMENTS

- A. Drawings and general provisions of the Contract, including General and Supplementary Conditions and other Division 01 Specification Sections, apply to this Section.

1.2 SUMMARY

- A. Section includes requirements for the submittal schedule and administrative and procedural requirements for submitting Shop Drawings, Product Data, Samples, and other submittals.

1.3 DEFINITIONS

- A. Action Submittals: Written and graphic information and physical samples that require Architect's responsive action. Action submittals are those submittals indicated in individual Specification Sections as "action submittals."
- B. Informational Submittals: Written and graphic information and physical samples that do not require Architect's responsive action. Submittals may be rejected for not complying with requirements. Informational submittals are those submittals indicated in individual Specification Sections as "informational submittals."
- C. Portable Document Format (PDF): An open standard file format licensed by Adobe Systems used for representing documents in a device-independent and display resolution-independent fixed-layout document format.

1.4 SUBMITTAL ADMINISTRATIVE REQUIREMENTS

- A. Architect's Digital Data Files: Electronic digital data files of the Contract Drawings will be provided by Architect for Contractor's use in preparing submittals.
 - 1. Architect will furnish Contractor one set of PDF drawing files of the Contract Drawings for use in preparing Shop Drawings and Project record drawings.
 - a. Architect makes no representations as to the accuracy or completeness of digital data drawing files as they relate to the Contract Drawings.
 - b. Contractor shall execute a data licensing agreement in the form of AIA Document C106, Digital Data Licensing Agreement or an Agreement form acceptable to Owner and Architect.
 - c. A processing fee may be required by the Architect to adapt the digital design data files for use by the Contractor. Such fees shall be paid by the Contractor to the Architect.
 - d. The following digital data files will be furnished for each appropriate discipline:
 - 1) Floor plans.
 - 2) Reflected ceiling plans.
- B. Coordination: Coordinate preparation and processing of submittals with performance of construction activities.

1. Coordinate each submittal with fabrication, purchasing, testing, delivery, other submittals, and related activities that require sequential activity.
 2. Submit all submittal items required for each Specification Section concurrently unless partial submittals for portions of the Work are indicated on approved submittal schedule.
 3. Submit action submittals and informational submittals required by the same Specification Section as separate packages under separate transmittals.
 4. Coordinate transmittal of different types of submittals for related parts of the Work so processing will not be delayed because of need to review submittals concurrently for coordination.
 - a. Architect reserves the right to withhold action on a submittal requiring coordination with other submittals until related submittals are received.
- C. Processing Time: Allow time for submittal review, including time for resubmittals, as follows. Time for review shall commence on Architect's receipt of submittal. No extension of the Contract Time will be authorized because of failure to transmit submittals enough in advance of the Work to permit processing, including resubmittals.
1. Initial Review: Allow 14 days for initial review of each submittal. Allow additional time if coordination with subsequent submittals is required. Architect will advise Contractor when a submittal being processed must be delayed for coordination.
 2. Intermediate Review: If intermediate submittal is necessary, process it in same manner as initial submittal.
 3. Resubmittal Review: Allow ten days for review of each resubmittal.
 4. Sequential Review: Where sequential review of submittals by Architect's consultants, Owner, or other parties is indicated, allow 21 days for initial review of each submittal.
 - a. Structural, HVAC, Plumbing, Fire Protection and Electrical components..
 5. Concurrent Consultant Review: Where the Contract Documents indicate that submittals may be transmitted simultaneously to Architect and to Architect's consultants, allow 14 days for review of each submittal. Submittal will be returned to Architect before being returned to Contractor.
- D. Paper Submittals: Place a permanent label or title block on each submittal item for identification.
1. Indicate name of firm or entity that prepared each submittal on label or title block.
 2. Provide a space approximately 6 by 8 inches on label or beside title block to record Contractor's review and approval markings and action taken by Architect.
 3. Include the following information for processing and recording action taken:
 - a. Project name.
 - b. Date.
 - c. Name of Architect.
 - d. Name of Contractor.
 - e. Name of subcontractor.
 - f. Name of supplier.
 - g. Name of manufacturer.
 - h. Submittal number or other unique identifier, including revision identifier.
 - 1) Submittal number shall use Specification Section number followed by a decimal point and then a sequential number (e.g., 061000.01). Resubmittals shall include an alphabetic suffix after another decimal point (e.g., 061000.01.A).
 - i. Number and title of appropriate Specification Section.
 - j. Drawing number and detail references, as appropriate.
 - k. Location(s) where product is to be installed, as appropriate.
 - l. Other necessary identification.

4. Additional Paper Copies: Unless additional copies are required for final submittal, and unless Architect observes noncompliance with provisions in the Contract Documents, initial submittal may serve as final submittal.
 - a. Submit one copy of submittal to concurrent reviewer in addition to specified number of copies to Architect.
5. Transmittal for Paper Submittals: Assemble each submittal individually and appropriately for transmittal and handling. Transmit each submittal using a transmittal form. Architect will discard submittals received from sources other than Contractor.
 - a. Transmittal Form for Paper Submittals: Use AIA Document G810 or similar form.
- E. Electronic Submittals: Identify and incorporate information in each electronic submittal file as follows:
 1. Assemble complete submittal package into a single indexed file incorporating submittal requirements of a single Specification Section and transmittal form with links enabling navigation to each item.
 2. Name file with submittal number or other unique identifier, including revision identifier.
 - a. File name shall use project identifier and Specification Section number followed by a decimal point and then a sequential number (e.g., LNHS-061000.01). Resubmittals shall include an alphabetic suffix after another decimal point (e.g., LNHS-061000.01.A).
 3. Provide means for insertion to permanently record Contractor's review and approval markings and action taken by Architect.
 4. Transmittal Form for Electronic Submittals: Use electronic form acceptable to Owner, containing the following information:
 - a. Project name.
 - b. Date.
 - c. Name and address of Architect.
 - d. Name of Contractor.
 - e. Name of firm or entity that prepared submittal.
 - f. Names of subcontractor, manufacturer, and supplier.
 - g. Submittal purpose and description.
 - h. Specification Section number and title.
 - i. Drawing number and detail references, as appropriate.
 - j. Location(s) where product is to be installed, as appropriate.
 - k. Related physical samples submitted directly.
 - l. Transmittal number, numbered consecutively.
 - m. Other necessary identification.
 - n. Remarks.
- F. Options: Identify options requiring selection by Architect.
- G. Deviations and Additional Information: On an attached separate sheet, prepared on Contractor's letterhead, record relevant information, requests for data, revisions other than those requested by Architect on previous submittals, and deviations from requirements in the Contract Documents, including minor variations and limitations. Include same identification information as related submittal.
- H. Resubmittals: Make resubmittals in same form and number of copies as initial submittal.
 1. Note date and content of previous submittal.
 2. Note date and content of revision in label or title block and clearly indicate extent of revision.

3. Resubmit submittals until they are marked with approval notation from Architect's action stamp.
- I. Distribution: Furnish copies of final submittals to manufacturers, subcontractors, suppliers, fabricators, installers, authorities having jurisdiction, and others as necessary for performance of construction activities. Show distribution on transmittal forms.
- J. Use for Construction: Retain complete copies of submittals on Project site. Use only final action submittals that are marked with approval notation from Architect's action stamp.

PART 2 - PRODUCTS

2.1 SUBMITTAL PROCEDURES

- A. General Submittal Procedure Requirements: Prepare and submit submittals required by individual Specification Sections. Types of submittals are indicated in individual Specification Sections.
 1. Submit electronic submittals via email as PDF electronic files.
 - a. Architect will return annotated file. Annotate and retain one copy of file as an electronic Project record document file.
 2. Action Submittals: Submit five paper copies of each submittal unless otherwise indicated. Architect will return three copies.
 3. Informational Submittals: Submit two paper copies of each submittal unless otherwise indicated. Architect will not return copies.
 4. Certificates and Certifications Submittals: Provide a statement that includes signature of entity responsible for preparing certification. Certificates and certifications shall be signed by an officer or other individual authorized to sign documents on behalf of that entity.
- B. Product Data: Collect information into a single submittal for each element of construction and type of product or equipment.
 1. If information must be specially prepared for submittal because standard published data are not suitable for use, submit as Shop Drawings, not as Product Data.
 2. Mark each copy of each submittal to show which products and options are applicable.
 3. Include the following information, as applicable:
 - a. Manufacturer's catalog cuts.
 - b. Manufacturer's product specifications.
 - c. Standard color charts.
 - d. Statement of compliance with specified referenced standards.
 - e. Testing by recognized testing agency.
 - f. Application of testing agency labels and seals.
 - g. Notation of coordination requirements.
 - h. Availability and delivery time information.
 4. For equipment, include the following in addition to the above, as applicable:
 - a. Wiring diagrams showing factory-installed wiring.
 - b. Printed performance curves.
 - c. Operational range diagrams.
 - d. Clearances required to other construction, if not indicated on accompanying Shop Drawings.
 5. Submit Product Data before or concurrent with Samples.

- C. Shop Drawings: Prepare Project-specific information, drawn accurately to scale. Do not base Shop Drawings on reproductions of the Contract Documents or standard printed data, unless submittal based on Architect's digital data drawing files is otherwise permitted.
1. Preparation: Fully illustrate requirements in the Contract Documents. Include the following information, as applicable:
 - a. Identification of products.
 - b. Schedules.
 - c. Compliance with specified standards.
 - d. Notation of coordination requirements.
 - e. Notation of dimensions established by field measurement.
 - f. Relationship and attachment to adjoining construction clearly indicated.
 - g. Seal and signature of professional engineer if specified.
 2. Sheet Size: Except for templates, patterns, and similar full-size drawings, submit Shop Drawings on sheets at least 8-1/2 by 11 inches, but no larger than 30 by 42 inches.
- D. Samples: Submit Samples for review of kind, color, pattern, and texture for a check of these characteristics with other elements and for a comparison of these characteristics between submittal and actual component as delivered and installed.
1. Transmit Samples that contain multiple, related components such as accessories together in one submittal package.
 2. Identification: Attach label on unexposed side of Samples that includes the following:
 - a. Generic description of Sample.
 - b. Product name and name of manufacturer.
 - c. Sample source.
 - d. Number and title of applicable Specification Section.
 - e. Specification paragraph number and generic name of each item.
 3. Disposition: Maintain sets of approved Samples at Project site, available for quality-control comparisons throughout the course of construction activity. Sample sets may be used to determine final acceptance of construction associated with each set.
 - a. Samples not incorporated into the Work, or otherwise designated as Owner's property, are the property of Contractor.
 4. Samples for Initial Selection: Submit manufacturer's color charts consisting of units or sections of units showing the full range of colors, textures, and patterns available.
 - a. Number of Samples: Submit one full set(s) of available choices where color, pattern, texture, or similar characteristics are required to be selected from manufacturer's product line. Architect will return submittal with options selected.
 5. Samples for Verification: Submit full-size units or Samples of size indicated, prepared from same material to be used for the Work, cured and finished in manner specified, and physically identical with material or product proposed for use, and that show full range of color and texture variations expected. Samples include, but are not limited to, the following: partial sections of manufactured or fabricated components; small cuts or containers of materials; complete units of repetitively used materials; swatches showing color, texture, and pattern; color range sets; and components used for independent testing and inspection.
 - a. Number of Samples: Submit three sets of Samples. Architect will retain two Sample sets; remainder will be returned.

- 1) Submit a single Sample where assembly details, workmanship, fabrication techniques, connections, operation, and other similar characteristics are to be demonstrated.
 - 2) If variation in color, pattern, texture, or other characteristic is inherent in material or product represented by a Sample, submit at least three sets of paired units that show approximate limits of variations.
- E. Product Schedule: As required in individual Specification Sections, prepare a written summary indicating types of products required for the Work and their intended location. Include the following information in tabular form:
1. Type of product. Include unique identifier for each product indicated in the Contract Documents or assigned by Contractor if none is indicated.
 2. Manufacturer and product name, and model number if applicable.
 3. Number and name of room or space.
 4. Location within room or space.
- F. Coordination Drawing Submittals: Comply with requirements specified in Division 01 Section "Project Management and Coordination."
- G. Application for Payment and Schedule of Values: Comply with requirements specified in Division 01 Section "Payment Procedures."
- H. Test and Inspection Reports and Schedule of Tests and Inspections Submittals: Comply with requirements specified in Division 01 Section "Quality Requirements."
- I. Closeout Submittals and Maintenance Material Submittals: Comply with requirements specified in Division 01 Section "Closeout Procedures."
- J. Maintenance Data: Comply with requirements specified in Division 01 Section "Operation and Maintenance Data."
- K. Qualification Data: Prepare written information that demonstrates capabilities and experience of firm or person. Include lists of completed projects with project names and addresses, contact information of architects and owners, and other information specified.
- L. Welding Certificates: Prepare written certification that welding procedures and personnel comply with requirements in the Contract Documents. Submit record of Welding Procedure Specification and Procedure Qualification Record on AWS forms. Include names of firms and personnel certified.
- M. Installer Certificates: Submit written statements on manufacturer's letterhead certifying that Installer complies with requirements in the Contract Documents and, where required, is authorized by manufacturer for this specific Project.
- N. Manufacturer Certificates: Submit written statements on manufacturer's letterhead certifying that manufacturer complies with requirements in the Contract Documents. Include evidence of manufacturing experience where required.
- O. Product Certificates: Submit written statements on manufacturer's letterhead certifying that product complies with requirements in the Contract Documents.
- P. Material Test Reports: Submit reports written by a qualified testing agency, on testing agency's standard form, indicating and interpreting test results of material for compliance with requirements in the Contract Documents.

- Q. Product Test Reports: Submit written reports indicating that current product produced by manufacturer complies with requirements in the Contract Documents. Base reports on evaluation of tests performed by manufacturer and witnessed by a qualified testing agency, or on comprehensive tests performed by a qualified testing agency.
- R. Research Reports: Submit written evidence, from a model code organization acceptable to authorities having jurisdiction, that product complies with building code in effect for Project. Include the following information:
 - 1. Name of evaluation organization.
 - 2. Date of evaluation.
 - 3. Time period when report is in effect.
 - 4. Product and manufacturers' names.
 - 5. Description of product.
 - 6. Test procedures and results.
 - 7. Limitations of use.
- S. Preconstruction Test Reports: Submit reports written by a qualified testing agency, on testing agency's standard form, indicating and interpreting results of tests performed before installation of product, for compliance with performance requirements in the Contract Documents.
- T. Compatibility Test Reports: Submit reports written by a qualified testing agency, on testing agency's standard form, indicating and interpreting results of compatibility tests performed before installation of product. Include written recommendations for primers and substrate preparation needed for adhesion.
- U. Field Test Reports: Submit written reports indicating and interpreting results of field tests performed either during installation of product or after product is installed in its final location, for compliance with requirements in the Contract Documents.
- V. Design Data: Prepare and submit written and graphic information, including, but not limited to, performance and design criteria, list of applicable codes and regulations, and calculations. Include list of assumptions and other performance and design criteria and a summary of loads. Include load diagrams if applicable. Provide name and version of software, if any, used for calculations. Include page numbers.

2.2 DELEGATED-DESIGN SERVICES

- A. Performance and Design Criteria: Where professional design services or certifications by a design professional are specifically required of Contractor by the Contract Documents, provide products and systems complying with specific performance and design criteria indicated.
 - 1. If criteria indicated are not sufficient to perform services or certification required, submit a written request for additional information to Architect.

PART 3 - EXECUTION

3.1 CONTRACTOR'S REVIEW

- A. Action and Informational Submittals: Review each submittal and check for coordination with other Work of the Contract and for compliance with the Contract Documents. Note corrections and field dimensions. Mark with approval stamp before submitting to Architect.
- B. Project Closeout and Maintenance Material Submittals: See requirements in Division 01 Section "Closeout Procedures."

- C. Approval Stamp: Stamp each submittal with a uniform, approval stamp. Include Project name and location, submittal number, Specification Section title and number, name of reviewer, date of Contractor's approval, and statement certifying that submittal has been reviewed, checked, and approved for compliance with the Contract Documents.

3.2 ARCHITECT'S ACTION

- A. Action Submittals: Architect will review each submittal, make marks to indicate corrections or revisions required, and return it. Architect will stamp each submittal with an action stamp and will mark stamp appropriately to indicate action.
- B. Informational Submittals: Architect will review each submittal and will not return it, or will return it if it does not comply with requirements. Architect will forward each submittal to appropriate party.
- C. Partial submittals prepared for a portion of the Work will be reviewed when use of partial submittals has received prior approval from Architect.
- D. Incomplete submittals are unacceptable, will be considered nonresponsive, and will be returned for resubmittal without review.
- E. Submittals not required by the Contract Documents may be returned by the Architect without action.

END OF SECTION 013300

SECTION 014000 - QUALITY REQUIREMENTS

PART 1 - GENERAL

1.1 RELATED DOCUMENTS

- A. Drawings and general provisions of the Contract, including General and Supplementary Conditions and other Division 01 Specification Sections, apply to this Section.

1.2 SUMMARY

- A. Section includes administrative and procedural requirements for quality assurance and quality control.
- B. Testing and inspecting services are required to verify compliance with requirements specified or indicated. These services do not relieve Contractor of responsibility for compliance with the Contract Document requirements.
 - 1. Specific quality-assurance and -control requirements for individual construction activities are specified in the Sections that specify those activities. Requirements in those Sections may also cover production of standard products.
 - 2. Specified tests, inspections, and related actions do not limit Contractor's other quality-assurance and -control procedures that facilitate compliance with the Contract Document requirements.
 - 3. Requirements for Contractor to provide quality-assurance and -control services required by Architect, Owner, or authorities having jurisdiction are not limited by provisions of this Section.
 - 4. Specific test and inspection requirements are not specified in this Section.

1.3 DEFINITIONS

- A. Quality-Assurance Services: Activities, actions, and procedures performed before and during execution of the Work to guard against defects and deficiencies and substantiate that proposed construction will comply with requirements.
- B. Quality-Control Services: Tests, inspections, procedures, and related actions during and after execution of the Work to evaluate that actual products incorporated into the Work and completed construction comply with requirements. Services do not include contract enforcement activities performed by Architect.
- C. Product Testing: Tests and inspections that are performed by an NRTL, an NVLAP, or a testing agency qualified to conduct product testing and acceptable to authorities having jurisdiction, to establish product performance and compliance with specified requirements.
- D. Source Quality-Control Testing: Tests and inspections that are performed at the source, e.g., plant, mill, factory, or shop.
- E. Field Quality-Control Testing: Tests and inspections that are performed on-site for installation of the Work and for completed Work.
- F. Testing Agency: An entity engaged to perform specific tests, inspections, or both. Testing laboratory shall mean the same as testing agency.

- G. Installer/Applicator/Erector: Contractor or another entity engaged by Contractor as an employee, Subcontractor, or Sub-subcontractor, to perform a particular construction operation, including installation, erection, application, and similar operations.
 - 1. Use of trade-specific terminology in referring to a trade or entity does not require that certain construction activities be performed by accredited or unionized individuals, or that requirements specified apply exclusively to specific trade(s).
- H. Experienced: When used with an entity or individual, "experienced" means having successfully completed a minimum of five previous projects similar in nature, size, and extent to this Project; being familiar with special requirements indicated; and having complied with requirements of authorities having jurisdiction.

1.4 CONFLICTING REQUIREMENTS

- A. Referenced Standards: If compliance with two or more standards is specified and the standards establish different or conflicting requirements for minimum quantities or quality levels, comply with the most stringent requirement. Refer conflicting requirements that are different, but apparently equal, to Architect for a decision before proceeding.
- B. Minimum Quantity or Quality Levels: The quantity or quality level shown or specified shall be the minimum provided or performed. The actual installation may comply exactly with the minimum quantity or quality specified, or it may exceed the minimum within reasonable limits. To comply with these requirements, indicated numeric values are minimum or maximum, as appropriate, for the context of requirements. Refer uncertainties to Architect for a decision before proceeding.

1.5 INFORMATIONAL SUBMITTALS

- A. Contractor's Quality-Control Plan: For quality-assurance and quality-control activities and responsibilities.
- B. Contractor's Statement of Responsibility: When required by authorities having jurisdiction, submit copy of written statement of responsibility sent to authorities having jurisdiction before starting work on the following systems:
 - 1. Seismic-force-resisting system, designated seismic system, or component listed in the designated seismic system quality-assurance plan prepared by Architect.

1.6 CONTRACTOR'S QUALITY-CONTROL PLAN

- A. Monitoring and Documentation: Maintain testing and inspection reports including log of approved and rejected results. Include work Architect has indicated as nonconforming or defective. Indicate corrective actions taken to bring nonconforming work into compliance with requirements. Comply with requirements of authorities having jurisdiction.

1.7 REPORTS AND DOCUMENTS

- A. Manufacturer's Technical Representative's Field Reports: Prepare written information documenting manufacturer's technical representative's tests and inspections specified in other Sections. Include the following:
 - 1. Name, address, and telephone number of technical representative making report.
 - 2. Statement on condition of substrates and their acceptability for installation of product.

3. Statement that products at Project site comply with requirements.
 4. Summary of installation procedures being followed, whether they comply with requirements and, if not, what corrective action was taken.
 5. Results of operational and other tests and a statement of whether observed performance complies with requirements.
 6. Statement whether conditions, products, and installation will affect warranty.
 7. Other required items indicated in individual Specification Sections.
- B. Factory-Authorized Service Representative's Reports: Prepare written information documenting manufacturer's factory-authorized service representative's tests and inspections specified in other Sections. Include the following:
1. Name, address, and telephone number of factory-authorized service representative making report.
 2. Statement that equipment complies with requirements.
 3. Results of operational and other tests and a statement of whether observed performance complies with requirements.
 4. Statement whether conditions, products, and installation will affect warranty.
 5. Other required items indicated in individual Specification Sections.
- C. Permits, Licenses, and Certificates: For Owner's records, submit copies of permits, licenses, certifications, inspection reports, releases, jurisdictional settlements, notices, receipts for fee payments, judgments, correspondence, records, and similar documents, established for compliance with standards and regulations bearing on performance of the Work.
- 1.8 QUALITY ASSURANCE
- A. General: Qualifications paragraphs in this article establish the minimum qualification levels required; individual Specification Sections specify additional requirements.
- B. Manufacturer Qualifications: A firm experienced in manufacturing products or systems similar to those indicated for this Project and with a record of successful in-service performance, as well as sufficient production capacity to produce required units.
- C. Fabricator Qualifications: A firm experienced in producing products similar to those indicated for this Project and with a record of successful in-service performance, as well as sufficient production capacity to produce required units.
- D. Installer Qualifications: A firm or individual experienced in installing, erecting, or assembling work similar in material, design, and extent to that indicated for this Project, whose work has resulted in construction with a record of successful in-service performance.
- E. Professional Engineer Qualifications: A professional engineer who is legally qualified to practice in jurisdiction where Project is located and who is experienced in providing engineering services of the kind indicated. Engineering services are defined as those performed for installations of the system, assembly, or product that are similar in material, design, and extent to those indicated for this Project.
- F. Testing Agency Qualifications: An NRTL, an NVLAP, or an independent agency with the experience and capability to conduct testing and inspecting indicated, as documented according to ASTM E 329; and with additional qualifications specified in individual Sections; and, where required by authorities having jurisdiction, that is acceptable to authorities.
1. NRTL: A nationally recognized testing laboratory according to 29 CFR 1910.7.
 2. NVLAP: A testing agency accredited according to NIST's National Voluntary Laboratory Accreditation Program.

- G. **Manufacturer's Technical Representative Qualifications:** An authorized representative of manufacturer who is trained and approved by manufacturer to observe and inspect installation of manufacturer's products that are similar in material, design, and extent to those indicated for this Project.
- H. **Factory-Authorized Service Representative Qualifications:** An authorized representative of manufacturer who is trained and approved by manufacturer to inspect installation of manufacturer's products that are similar in material, design, and extent to those indicated for this Project.

1.9 QUALITY CONTROL

- A. **Owner Responsibilities:** Where quality-control services are indicated as Owner's responsibility, Owner will engage a qualified testing agency to perform these services.
 - 1. Owner will furnish Contractor with names, addresses, and telephone numbers of testing agencies engaged and a description of types of testing and inspecting they are engaged to perform.
 - 2. Costs for retesting and reinspecting construction that replaces or is necessitated by work that failed to comply with the Contract Documents will be charged to Contractor, and the Contract Sum will be adjusted by Change Order.
- B. **Contractor Responsibilities:** Tests and inspections not explicitly assigned to Owner are Contractor's responsibility. Perform additional quality-control activities required to verify that the Work complies with requirements, whether specified or not.
 - 1. Unless otherwise indicated, provide quality-control services specified and those required by authorities having jurisdiction. Perform quality-control services required of Contractor by authorities having jurisdiction, whether specified or not.
 - 2. Where services are indicated as Contractor's responsibility, engage a qualified testing agency to perform these quality-control services.
 - a. Contractor shall not employ same entity engaged by Owner, unless agreed to in writing by Owner.
 - 3. Notify testing agencies at least 24 hours in advance of time when Work that requires testing or inspecting will be performed.
 - 4. Testing and inspecting requested by Contractor and not required by the Contract Documents are Contractor's responsibility.
 - 5. Submit additional copies of each written report directly to authorities having jurisdiction, when they so direct.
- C. **Manufacturer's Field Services:** Where indicated, engage a factory-authorized service representative to inspect field-assembled components and equipment installation, including service connections. Report results in writing as specified in Section 013300 "Submittal Procedures."
- D. **Manufacturer's Technical Services:** Where indicated, engage a manufacturer's technical representative to observe and inspect the Work. Manufacturer's technical representative's services include participation in preinstallation conferences, examination of substrates and conditions, verification of materials, observation of Installer activities, inspection of completed portions of the Work, and submittal of written reports.
- E. **Retesting/Reinspecting:** Regardless of whether original tests or inspections were Contractor's responsibility, provide quality-control services, including retesting and reinspecting, for construction that replaced Work that failed to comply with the Contract Documents.

- F. Testing Agency Responsibilities: Cooperate with Architect and Contractor in performance of duties. Provide qualified personnel to perform required tests and inspections.
1. Notify Architect and Contractor promptly of irregularities or deficiencies observed in the Work during performance of its services.
 2. Determine the location from which test samples will be taken and in which in-situ tests are conducted.
 3. Conduct and interpret tests and inspections and state in each report whether tested and inspected work complies with or deviates from requirements.
 4. Submit a certified written report, in duplicate, of each test, inspection, and similar quality-control service through Contractor.
 5. Do not release, revoke, alter, or increase the Contract Document requirements or approve or accept any portion of the Work.
 6. Do not perform any duties of Contractor.
- G. Associated Services: Cooperate with agencies performing required tests, inspections, and similar quality-control services, and provide reasonable auxiliary services as requested. Notify agency sufficiently in advance of operations to permit assignment of personnel. Provide the following:
1. Access to the Work.
 2. Incidental labor and facilities necessary to facilitate tests and inspections.
 3. Adequate quantities of representative samples of materials that require testing and inspecting. Assist agency in obtaining samples.
 4. Facilities for storage and field curing of test samples.
 5. Delivery of samples to testing agencies.
 6. Preliminary design mix proposed for use for material mixes that require control by testing agency.
 7. Security and protection for samples and for testing and inspecting equipment at Project site.
- H. Coordination: Coordinate sequence of activities to accommodate required quality-assurance and -control services with a minimum of delay and to avoid necessity of removing and replacing construction to accommodate testing and inspecting.
1. Schedule times for tests, inspections, obtaining samples, and similar activities.

1.10 SPECIAL TESTS AND INSPECTIONS

- A. Special Tests and Inspections: Owner will engage a qualified special inspector to conduct special tests and inspections required by authorities having jurisdiction as the responsibility of Owner, as indicated in Statement of Special Inspections, and as follows:
1. Notifying Architect and Contractor promptly of irregularities and deficiencies observed in the Work during performance of its services.
 2. Submitting a certified written report of each test, inspection, and similar quality-control service to Architect with copy to Contractor and to authorities having jurisdiction.
 3. Submitting a final report of special tests and inspections at Substantial Completion, which includes a list of unresolved deficiencies.
 4. Interpreting tests and inspections and stating in each report whether tested and inspected work complies with or deviates from the Contract Documents.
 5. Retesting and reinspecting corrected work.

PART 2 - PRODUCTS (Not Used)

PART 3 - EXECUTION

3.1 TEST AND INSPECTION LOG

- A. Test and Inspection Log: Prepare a record of tests and inspections. Include the following:
 - 1. Date test or inspection was conducted.
 - 2. Description of the Work tested or inspected.
 - 3. Date test or inspection results were transmitted to Architect.
 - 4. Identification of testing agency or special inspector conducting test or inspection.
- B. Maintain log at Project site. Post changes and revisions as they occur. Provide access to test and inspection log for Architect's reference during normal working hours.

3.2 REPAIR AND PROTECTION

- A. General: On completion of testing, inspecting, sample taking, and similar services, repair damaged construction and restore substrates and finishes.
 - 1. Provide materials and comply with installation requirements specified in other Specification Sections or matching existing substrates and finishes. Restore patched areas and extend restoration into adjoining areas with durable seams that are as invisible as possible. Comply with the Contract Document requirements for cutting and patching in Section 017300 "Execution."
- B. Protect construction exposed by or for quality-control service activities.
- C. Repair and protection are Contractor's responsibility, regardless of the assignment of responsibility for quality-control services.

END OF SECTION 014000

SECTION 014200 - REFERENCES

PART 1 - GENERAL

1.1 RELATED DOCUMENTS

- A. Drawings and general provisions of the Contract, including General and Supplementary Conditions and other Division 01 Specification Sections, apply to this Section.

1.2 DEFINITIONS

- A. General: Basic Contract definitions are included in the Conditions of the Contract.
- B. "Approved": When used to convey Architect's action on Contractor's submittals, applications, and requests, "approved" is limited to Architect's duties and responsibilities as stated in the Conditions of the Contract.
- C. "Directed": A command or instruction by Architect. Other terms including "requested," "authorized," "selected," "required," and "permitted" have the same meaning as "directed."
- D. "Indicated": Requirements expressed by graphic representations or in written form on Drawings, in Specifications, and in other Contract Documents. Other terms including "shown," "noted," "scheduled," and "specified" have the same meaning as "indicated."
- E. "Regulations": Laws, ordinances, statutes, and lawful orders issued by authorities having jurisdiction, and rules, conventions, and agreements within the construction industry that control performance of the Work.
- F. "Furnish": Supply and deliver to Project site, ready for unloading, unpacking, assembly, installation, and similar operations.
- G. "Install": Operations at Project site including unloading, temporarily storing, unpacking, assembling, erecting, placing, anchoring, applying, working to dimension, finishing, curing, protecting, cleaning, and similar operations.
- H. "Provide": Furnish and install, complete and ready for the intended use.
- I. "Project Site": Space available for performing construction activities. The extent of Project site is shown on Drawings and may or may not be identical with the description of the land on which Project is to be built.

1.3 INDUSTRY STANDARDS

- A. Applicability of Standards: Unless the Contract Documents include more stringent requirements, applicable construction industry standards have the same force and effect as if bound or copied directly into the Contract Documents to the extent referenced. Such standards are made a part of the Contract Documents by reference.
- B. Publication Dates: Comply with standards in effect as of date of the Contract Documents unless otherwise indicated.

1.4 ABBREVIATIONS AND ACRONYMS

- A. Industry Organizations: Where abbreviations and acronyms are used in Specifications or other Contract Documents, they shall mean the recognized name of the entities indicated in Thomson Gale's "Encyclopedia of Associations" or in Columbia Books' "National Trade & Professional Associations of the U.S."

AA	Aluminum Association (The) www.aluminum.org	(703) 358-2960
AABC	Associated Air Balance Council www.aabchq.com	(202) 737-0202
AAMA	American Architectural Manufacturers Association www.aamanet.org	(847) 303-5664
AASHTO	American Association of State Highway and Transportation Officials www.transportation.org	(202) 624-5800
AATCC	American Association of Textile Chemists and Colorists www.aatcc.org	(919) 549-8141
ABAA	Air Barrier Association of America www.airbarrier.org	(866) 956-5888
ABMA	American Bearing Manufacturers Association www.abma-dc.org	(202) 367-1155
ACI	American Concrete Institute www.concrete.org	(248) 848-3700
ACPA	American Concrete Pipe Association www.concrete-pipe.org	(972) 506-7216
AEIC	Association of Edison Illuminating Companies, Inc. (The) www.aeic.org	(205) 257-2530
AF&PA	American Forest & Paper Association www.afandpa.org	(800) 878-8878 (202) 463-2700
AGA	American Gas Association www.aga.org	(202) 824-7000
AHAM	Association of Home Appliance Manufacturers www.aham.org	(202) 872-5955
AHRI	Air-Conditioning, Heating, and Refrigeration Institute, The www.ahrinet.org	(703) 524-8800
AI	Asphalt Institute www.asphaltinstitute.org	(859) 288-4960
AIA	American Institute of Architects (The) www.aia.org	(800) 242-3837 (202) 626-7300
AISC	American Institute of Steel Construction www.aisc.org	(800) 644-2400 (312) 670-2400
AISI	American Iron and Steel Institute www.steel.org	(202) 452-7100

REFERENCES

AITC	American Institute of Timber Construction www.aitc-glulam.org	(303) 792-9559
ALSC	American Lumber Standard Committee, Incorporated www.alsc.org	(301) 972-1700
AMCA	Air Movement and Control Association International, Inc. www.amca.org	(847) 394-0150
ANSI	American National Standards Institute www.ansi.org	(202) 293-8020
AOSA	Association of Official Seed Analysts, Inc. www.aosaseed.com	(405) 780-7372
APA	APA - The Engineered Wood Association www.apawood.org	(253) 565-6600
APA	Architectural Precast Association www.archprecast.org	(239) 454-6989
API	American Petroleum Institute www.api.org	(202) 682-8000
ARI	Air-Conditioning & Refrigeration Institute www.ari.org	(703) 524-8800
ARMA	Asphalt Roofing Manufacturers Association www.asphaltroofing.org	(202) 207-0917
ASCE	American Society of Civil Engineers www.asce.org	(800) 548-2723 (703) 295-6300
ASCE/SEI	American Society of Civil Engineers/Structural Engineering Institute (See ASCE)	
ASHRAE	American Society of Heating, Refrigerating and Air-Conditioning Engineers www.ashrae.org	(800) 527-4723 (404) 636-8400
ASME	ASME International (American Society of Mechanical Engineers International) www.asme.org	(800) 843-2763 (973) 882-1170
ASSE	American Society of Sanitary Engineering www.asse-plumbing.org	(440) 835-3040
ASTM	ASTM International (American Society for Testing and Materials International) www.astm.org	(610) 832-9500
ATIS	Alliance for Telecommunications Industry Solutions www.atis.org	(202) 628-6380
AWCMA	American Window Covering Manufacturers Association (Now WCMA)	
AWCI	Association of the Wall and Ceiling Industry www.awci.org	(703) 534-8300
AWI	Architectural Woodwork Institute	(571) 323-3636

	www.awinet.org	
AWPA	American Wood Protection Association (Formerly: American Wood Preservers' Association) www.awpa.com	(205) 733-4077
AWS	American Welding Society www.aws.org	(800) 443-9353 (305) 443-9353
AWWA	American Water Works Association www.awwa.org	(800) 926-7337 (303) 794-7711
BHMA	Builders Hardware Manufacturers Association www.buildershardware.com	(212) 297-2122
BIA	Brick Industry Association (The) www.bia.org	(703) 620-0010
BICSI	BICSI, Inc. www.bicsi.org	(800) 242-7405 (813) 979-1991
BIFMA	BIFMA International (Business and Institutional Furniture Manufacturer's Association International) www.bifma.com	(616) 285-3963
BISSC	Baking Industry Sanitation Standards Committee www.bissc.org	(866) 342-4772
	Carpet Cushion Council www.carpetcushion.org	(610) 527-3880
CDA	Copper Development Association www.copper.org	(800) 232-3282 (212) 251-7200
CEA	Canadian Electricity Association www.canelect.ca	(613) 230-9263
CEA	Consumer Electronics Association www.ce.org	(866) 858-1555 (703) 907-7600
CFFA	Chemical Fabrics & Film Association, Inc. www.chemicalfabricsandfilm.com	(216) 241-7333
CGA	Compressed Gas Association www.cganet.com	(703) 788-2700
CIMA	Cellulose Insulation Manufacturers Association www.cellulose.org	(888) 881-2462 (937) 222-2462
CISCA	Ceilings & Interior Systems Construction Association www.cisca.org	(630) 584-1919
CISPI	Cast Iron Soil Pipe Institute www.cispi.org	(423) 892-0137
CLFMI	Chain Link Fence Manufacturers Institute www.chainlinkinfo.org	(301) 596-2583
CPA	Composite Panel Association www.pbmdf.com	(703) 724-1128

CRI	Carpet and Rug Institute (The) www.carpet-rug.com	(800) 882-8846 (706) 278-3176
CRRC	Cool Roof Rating Council www.coolroofs.org	(866) 465-2523 (510) 485-7175
CRSI	Concrete Reinforcing Steel Institute www.crsi.org	(847) 517-1200 (800) 328-6306
CRRC	Cool Roof Rating Council www.coolroofs.org	(866) 465-2523 (510) 485-7175
CSA	Canadian Standards Association www.csa.ca	(800) 463-6727 (416) 747-4000
CSA	CSA International (Formerly: IAS - International Approval Services) www.csa-international.org	(866) 797-4272 (416) 747-4000
CSI	Construction Specifications Institute (The) www.csinet.org	(800) 689-2900 (703) 684-0300
CSSB	Cedar Shake & Shingle Bureau www.cedarbureau.org	(604) 820-7700
CTI	Cooling Technology Institute (Formerly: Cooling Tower Institute) www.cti.org	(281) 583-4087
DHI	Door and Hardware Institute www.dhi.org	(703) 222-2010
ECA	Electrical Components Association www.ec-central.org	(703)907-8024
EIA	Electronic Industries Alliance www.eia.org	(703) 907-7500
EIMA	EIFS Industry Members Association www.eima.com	(800) 294-3462 (770) 968-7945
EJCDC	Engineers Joint Contract Documents Committee http://content.asce.org/ejcdc/	(703) 295-6000
EJMA	Expansion Joint Manufacturers Association, Inc. www.ejma.org	(914) 332-0040
ESD	ESD Association (Electrostatic Discharge Association) www.esda.org	(315) 339-6937
ETL SEMCO	Intertek ETL SEMCO (Formerly: ITS - Intertek Testing Service NA) www.intertek-etlsemko.com	(800) 967-5352
FIBA	Federation Internationale de Basketball (The International Basketball Federation) www.fiba.com	41 22 545 00 00
FIVB	Federation Internationale de Volleyball	41 21 345 35 35

	(The International Volleyball Federation) www.fivb.ch	
FM Approvals	FM Approvals LLC www.fmglobal.com	(781) 762-4300
FM Global	FM Global (Formerly: FMG - FM Global) www.fmglobal.com	(401) 275-3000
FRSA	Florida Roofing, Sheet Metal & Air Conditioning Contractors Association, Inc. www.floridarroof.com	(407) 671-3772
FSA	Fluid Sealing Association www.fluidsealing.com	(610) 971-4850
FSC	Forest Stewardship Council www.fsc.org	49 228 367 66 0
GA	Gypsum Association www.gypsum.org	(301) 277-8686
GANA	Glass Association of North America www.glasswebsite.com	(785) 271-0208
GRI	(Part of GSI)	
GS	Green Seal www.greenseal.org	(202) 872-6400
GSI	Geosynthetic Institute www.geosynthetic-institute.org	(610) 522-8440
HI	Hydronics Institute www.gamanet.org	(908) 464-8200
HI/GAMA	Hydronics Institute/Gas Appliance Manufacturers Association Division of Air-Conditioning, Heating, and Refrigeration Institute (AHRI) www.ahrinet.org	(908) 464-8200
HMMA	Hollow Metal Manufacturers Association (Part of NAAMM)	
HPVA	Hardwood Plywood & Veneer Association www.hpva.org	(703) 435-2900
HPW	H. P. White Laboratory, Inc. www.hpwhite.com	(410) 838-6550
IAPSC	International Association of Professional Security Consultants www.iapsc.org	(515) 282-8192
ICBO	International Conference of Building Officials www.iccsafe.org	(888) 422-7233
ICEA	Insulated Cable Engineers Association, Inc. www.icea.net	(770) 830-0369
ICRI	International Concrete Repair Institute, Inc.	(847) 827-0830

	www.icri.org	
ICPA	International Cast Polymer Association www.icpa-hq.org	(703) 525-0320
IEC	International Electrotechnical Commission www.iec.ch	41 22 919 02 11
IEEE	Institute of Electrical and Electronics Engineers, Inc. (The) www.ieee.org	(212) 419-7900
IES	Illuminating Engineering Society of North America www.iesna.org	(703) 525-0320
IEST	Institute of Environmental Sciences and Technology www.iest.org	(847) 255-1561
IGMA	Insulating Glass Manufacturers Alliance www.igmaonline.org	(613) 233-1510
ILI	Indiana Limestone Institute of America, Inc. www.iliai.com	(812) 275-4426
ISA	Instrumentation, Systems, and Automation Society, The www.isa.org	(919) 549-8411
ISO	International Organization for Standardization www.iso.ch	41 22 749 01 11
ISSFA	International Solid Surface Fabricators Association www.issfa.net	(877) 464-7732 (801) 341-7360
ITS	Intertek Testing Service NA (Now ETL SEMCO)	
ITU	International Telecommunication Union www.itu.int/home	41 22 730 51 11
KCMA	Kitchen Cabinet Manufacturers Association www.kcma.org	(703) 264-1690
LGSEA	Light Gauge Steel Engineers Association www.arcat.com	(202) 263-4488
LMA	Laminating Materials Association (Now part of CPA)	
LPI	Lightning Protection Institute www.lightning.org	(800) 488-6864
MBMA	Metal Building Manufacturers Association www.mbma.com	(216) 241-7333
MCA	Metal Construction Association www.metalconstruction.org	(847) 375-4718
MFMA	Maple Flooring Manufacturers Association, Inc. www.maplefloor.org	(888) 480-9138
MFMA	Metal Framing Manufacturers Association, Inc. www.metalframingmfg.org	(312) 644-6610

MH	Material Handling (Now MHIA)	
MHIA	Material Handling Industry of America www.mhia.org	(800) 345-1815 (704) 676-1190
MIA	Marble Institute of America www.marble-institute.com	(440) 250-9222
MPI	Master Painters Institute www.paintinfo.com	(888) 674-8937 (604) 298-7578
MSS	Manufacturers Standardization Society of The Valve and Fittings Industry Inc. www.mss-hq.com	(703) 281-6613
NAAMM	National Association of Architectural Metal Manufacturers www.naamm.org	(630) 942-6591
NACE	NACE International (National Association of Corrosion Engineers International) www.nace.org	(800) 797-6223 (281) 228-6200
NADCA	National Air Duct Cleaners Association www.nadca.com	(202) 737-2926
NAGWS	National Association for Girls and Women in Sport www.aahperd.org/nagws/	(800) 213-7193, ext. 453
NAIMA	North American Insulation Manufacturers Association www.naima.org	(703) 684-0084
NBGQA	National Building Granite Quarries Association, Inc. www.nbgqa.com	(800) 557-2848
NCAA	National Collegiate Athletic Association (The) www.ncaa.org	(317) 917-6222
NCMA	National Concrete Masonry Association www.ncma.org	(703) 713-1900
NCTA	National Cable & Telecommunications Association www.ncta.com	(202) 222-2300
NEBB	National Environmental Balancing Bureau www.nebb.org	(301) 977-3698
NECA	National Electrical Contractors Association www.necanet.org	(301) 657-3110
NeLMA	Northeastern Lumber Manufacturers' Association www.nelma.org	(207) 829-6901
NEMA	National Electrical Manufacturers Association www.nema.org	(703) 841-3200
NETA	InterNational Electrical Testing Association www.netaworld.org	(888) 300-6382 (269) 488-6382

NFHS	National Federation of State High School Associations www.nfhs.org	(317) 972-6900
NFPA	NFPA (National Fire Protection Association) www.nfpa.org	(800) 344-3555 (617) 770-3000
NFRC	National Fenestration Rating Council www.nfrc.org	(301) 589-1776
NGA	National Glass Association www.glass.org	(866) 342-5642 (703) 442-4890
NHLA	National Hardwood Lumber Association www.natllhardwood.org	(800) 933-0318 (901) 377-1818
NLGA	National Lumber Grades Authority www.nlga.org	(604) 524-2393
NOFMA	NOFMA: The Wood Flooring Manufacturers Association (Formerly: National Oak Flooring Manufacturers Association) www.nofma.org	(901) 526-5016
NOMMA	National Ornamental & Miscellaneous Metals Association www.nomma.org	(888) 516-8585
NRCA	National Roofing Contractors Association www.nrca.net	(800) 323-9545 (847) 299-9070
NRMCA	National Ready Mixed Concrete Association www.nrmca.org	(888) 846-7622 (301) 587-1400
NSF	NSF International (National Sanitation Foundation International) www.nsf.org	(800) 673-6275 (734) 769-8010
NSSGA	National Stone, Sand & Gravel Association www.nssga.org	(800) 342-1415 (703) 525-8788
NTMA	National Terrazzo & Mosaic Association, Inc. (The) www.ntma.com	(800) 323-9736 (540) 751-0930
NWFA	National Wood Flooring Association www.nwfa.org	(800) 422-4556 (636) 519-9663
PCI	Precast/Prestressed Concrete Institute www.pci.org	(312) 786-0300
PDI	Plumbing & Drainage Institute www.pdionline.org	(800) 589-8956 (978) 557-0720
PGI	PVC Geomembrane Institute http://pgi-tp.cee.uiuc.edu	(217) 333-3929
PTI	Post-Tensioning Institute www.post-tensioning.org	(248) 848-3180
RCSC	Research Council on Structural Connections www.boltcouncil.org	
RFCI	Resilient Floor Covering Institute	

	www.rfci.com	(706) 882-3833
RIS	Redwood Inspection Service www.redwoodinspection.com	(925) 935-1499
SAE	SAE International www.sae.org	(877) 606-7323 (724) 776-4841
SCAQMD	South Coast Air Quality Management District www.aqmd.com	(909) 396-2000
SCTE	Society of Cable Telecommunications Engineers www.scte.org	(800) 542-5040 (610) 363-6888
SDI	Steel Deck Institute www.sdi.org	(847) 458-4647
SDI	Steel Door Institute www.steeldoor.org	(440) 899-0010
SEFA	Scientific Equipment and Furniture Association www.sefalabs.com	(877) 294-5424 (516) 294-5424
SEI/ASCE	Structural Engineering Institute/American Society of Civil Engineers (See ASCE)	
SIA	Security Industry Association www.siaonline.org	(866) 817-8888 (703) 683-2075
SJI	Steel Joist Institute www.steeljoist.org	(843) 626-1995
SMA	Screen Manufacturers Association www.smacentral.org	(561) 533-0991
SMACNA	Sheet Metal and Air Conditioning Contractors' National Association www.smacna.org	(703) 803-2980
SMPTE	Society of Motion Picture and Television Engineers www.smpte.org	(914) 761-1100
SPFA	Spray Polyurethane Foam Alliance (Formerly: SPI/SPFD - The Society of the Plastics Industry, Inc.; Spray Polyurethane Foam Division) www.sprayfoam.org	(800) 523-6154
SPIB	Southern Pine Inspection Bureau (The) www.spib.org	(850) 434-2611
SPRI	Single Ply Roofing Industry www.spri.org	(781) 647-7026
SSINA	Specialty Steel Industry of North America www.ssina.com	(800) 982-0355 (202) 342-8630
SSPC	SSPC: The Society for Protective Coatings www.sspc.org	(877) 281-7772 (412) 281-2331
STI	Steel Tank Institute www.steeltank.com	(847) 438-8265

SWI	Steel Window Institute www.steelwindows.com	(216) 241-7333
SWPA	Submersible Wastewater Pump Association www.swpa.org	(847) 681-1868
TCA	Tilt-Up Concrete Association www.tilt-up.org	(319) 895-6911
TCNA	Tile Council of North America, Inc. www.tileusa.com	(864) 646-8453
TEMA	Tubular Exchanger Manufacturers Association www.tema.org	(914) 332-0040
TIA/EIA	Telecommunications Industry Association/Electronic Industries Alliance www.tiaonline.org	(703) 907-7700
TMS	The Masonry Society www.masonrysociety.org	(303) 939-9700
TPI	Truss Plate Institute, Inc. www.tpinst.org	(703) 683-1010
TPI	Turfgrass Producers International www.turfgrassod.org	(800) 405-8873 (847) 649-5555
TRI	Tile Roofing Institute www.tilerroofing.org	(312) 670-4177
UL	Underwriters Laboratories Inc. www.ul.com	(877) 854-3577 (847) 272-8800
UNI	Uni-Bell PVC Pipe Association www.uni-bell.org	(972) 243-3902
USAV	USA Volleyball www.usavolleyball.org	(888) 786-5539 (719) 228-6800
USGBC	U.S. Green Building Council www.usgbc.org	(800) 795-1747
USITT	United States Institute for Theatre Technology, Inc. www.usitt.org	(800) 938-7488 (315) 463-6463
WASTEC	Waste Equipment Technology Association www.wastec.org	(800) 424-2869 (202) 244-4700
WCLIB	West Coast Lumber Inspection Bureau www.wclib.org	(800) 283-1486 (503) 639-0651
WCMA	Window Covering Manufacturers Association www.wcmanet.org	(212) 297-2122
WDMA	Window & Door Manufacturers Association (Formerly: NWWDA - National Wood Window and Door Association) www.wdma.com	(800) 223-2301 (312) 321-6802

WI	Woodwork Institute (Formerly: WIC - Woodwork Institute of California) www.wicnet.org	(916) 372-9943
WMMPA	Wood Moulding & Millwork Producers Association www.wmmpa.com	(800) 550-7889 (530) 661-9591
WSRCA	Western States Roofing Contractors Association www.wsrca.com	(800) 725-0333 (650) 570-5441
WWPA	Western Wood Products Association www.wwpa.org	(503) 224-3930

Retain "Code Agencies" Paragraph below if required. The Section Text in MasterSpec Sections is prepared assuming list is retained.

- B. Code Agencies: Where abbreviations and acronyms are used in Specifications or other Contract Documents, they shall mean the recognized name of the entities in the following list. Names, telephone numbers, and Web sites are subject to change and are believed to be accurate and up-to-date as of the date of the Contract Documents.

IAPMO	International Association of Plumbing and Mechanical Officials www.iapmo.org	(909) 472-4100
ICC	International Code Council www.iccsafe.org	(888) 422-7233
ICC-ES	ICC Evaluation Service, Inc. www.icc-es.org	(800) 423-6587 (562) 699-0543

Retain "Federal Government Agencies" Paragraph below if required. The Section Text in MasterSpec Sections is prepared assuming list is retained.

- C. Federal Government Agencies: Where abbreviations and acronyms are used in Specifications or other Contract Documents, they shall mean the recognized name of the entities in the following list. Names, telephone numbers, and Web sites are subject to change and are believed to be accurate and up-to-date as of the date of the Contract Documents.

COE	Army Corps of Engineers www.usace.army.mil	(202) 761-0011
CPSC	Consumer Product Safety Commission www.cpsc.gov	(800) 638-2772 (301) 504-7923
DOC	Department of Commerce www.commerce.gov	(202) 482-2000
DOD	Department of Defense http://dodssp.daps.dla.mil	(215) 697-6257
DOE	Department of Energy www.energy.gov	(202) 586-9220
EPA	Environmental Protection Agency www.epa.gov	(202) 272-0167

FAA	Federal Aviation Administration www.faa.gov	(866) 835-5322
FCC	Federal Communications Commission www.fcc.gov	(888) 225-5322
FDA	Food and Drug Administration www.fda.gov	(888) 463-6332
GSA	General Services Administration www.gsa.gov	(800) 488-3111
HUD	Department of Housing and Urban Development www.hud.gov	(202) 708-1112
LBL	Lawrence Berkeley National Laboratory www.lbl.gov	(510) 486-4000
NCHRP	National Cooperative Highway Research Program (See TRB)	
NIST	National Institute of Standards and Technology www.nist.gov	(301) 975-6478
OSHA	Occupational Safety & Health Administration www.osha.gov	(800) 321-6742 (202) 693-1999
PBS	Public Buildings Service (See GSA)	
PHS	Office of Public Health and Science http://www.hhs.gov/ophs/	(202) 690-7694
RUS	Rural Utilities Service (See USDA)	(202) 720-9540
SD	State Department www.state.gov	(202) 647-4000
TRB	Transportation Research Board http://gulliver.trb.org	(202) 334-2934
USDA	Department of Agriculture www.usda.gov	(202) 720-2791
USP	U.S. Pharmacopeia www.usp.org	(800) 227-8772
USPS	Postal Service www.usps.com	(202) 268-2000

Retain "Standards and Regulations" Paragraph below if required. The Section Text in MasterSpec Sections is prepared assuming list is retained.

- D. Standards and Regulations: Where abbreviations and acronyms are used in Specifications or other Contract Documents, they shall mean the recognized name of the standards and regulations in the following list. Names, telephone numbers, and Web sites are subject to change and are believed to be accurate and up-to-date as of the date of the Contract Documents.

ADAAG Americans with Disabilities Act (ADA) (800) 872-2253

REFERENCES

014200 - 13
2/3/15

CDHS	California Department of Health Services www.dhcs.ca.gov	(916) 445-4171
CDPH	California Department of Public Health, Indoor Air Quality Section www.cal-iaq.org	
CPUC	California Public Utilities Commission www.cpuc.ca.gov	(415) 703-2782
TFS	Texas Forest Service Forest Resource Development http://txforestservation.tamu.edu	(979) 458-6606

PART 2 - PRODUCTS (Not Used)

PART 3 - EXECUTION (Not Used)

END OF SECTION 014200

SECTION 015000 - TEMPORARY FACILITIES AND CONTROLS

PART 1 - GENERAL

1.1 RELATED DOCUMENTS

- A. Drawings and general provisions of the Contract, including General and Supplementary Conditions and other Division 01 Specification Sections, apply to this Section.

1.2 SUMMARY

- A. Section includes requirements for temporary utilities, support facilities, and security and protection facilities.
 - 1. Project Signs
 - 2. Site Enclosure Fence

1.3 USE CHARGES

- A. Water and Sewer Service from Existing System: Water from Owner's existing water system is available for use without metering and without payment of use charges. Provide connections and extensions of services as required for construction operations.
- B. Electric Power Service from Existing System: Electric power from Owner's existing system is available for use without metering and without payment of use charges. Provide connections and extensions of services as required for construction operations.

1.4 INFORMATIONAL SUBMITTALS

- A. Fire-Safety Program: Show compliance with requirements of NFPA 241 and authorities having jurisdiction. Indicate Contractor personnel responsible for management of fire-prevention program.
- B. Moisture-Protection Plan: Describe procedures and controls for protecting materials and construction from water absorption and damage.
 - 1. Describe delivery, handling, and storage provisions for materials subject to water absorption or water damage.
 - 2. Indicate procedures for discarding water-damaged materials, protocols for mitigating water intrusion into completed Work, and replacing water-damaged Work.
 - 3. Indicate sequencing of work that requires water, such as sprayed fire-resistive materials, plastering, and terrazzo grinding, and describe plans for dealing with water from these operations. Show procedures for verifying that wet construction has dried sufficiently to permit installation of finish materials.
- C. Dust- and HVAC-Control Plan: Submit coordination drawing and narrative that indicates the dust- and HVAC-control measures proposed for use, proposed locations, and proposed time frame for their operation. Identify further options if proposed measures are later determined to be inadequate. Include the following:

1. Locations of dust-control partitions and other measures at each phase of work.

1.5 QUALITY ASSURANCE

- A. Electric Service: Comply with NECA, NEMA, and UL standards and regulations for temporary electric service. Install service to comply with NFPA 70.
- B. Tests and Inspections: Arrange for authorities having jurisdiction to test and inspect each temporary utility before use. Obtain required certifications and permits.
- C. Accessible Temporary Egress: Comply with applicable provisions in the U.S. Architectural & Transportation Barriers Compliance Board's ADA-ABA Accessibility Guidelines and ICC/ANSI A117.1 from occupied portions of the facility.

1.6 PROJECT CONDITIONS

- A. Temporary Use of Permanent Facilities: Engage Installer of each permanent service to assume responsibility for operation, maintenance, and protection of each permanent service during its use as a construction facility before Owner's acceptance, regardless of previously assigned responsibilities.

PART 2 - PRODUCTS

2.1 MATERIALS

- A. Chain-Link Fencing: Minimum 2-inch, 0.148-inch- thick, galvanized-steel, chain-link fabric fencing; minimum 6 feet high with galvanized-steel pipe posts; minimum 2-3/8-inch- OD line posts and 2-7/8-inch- OD corner and pull posts, with 1-5/8-inch- OD top rails.
- B. Portable Chain-Link Fencing: Minimum 2-inch, 0.148-inch- thick, galvanized-steel, chain-link fabric fencing; minimum 6 feet high with galvanized-steel pipe posts; minimum 2-3/8-inch- OD line posts and 2-7/8-inch- OD corner and pull posts, with 1-5/8-inch- OD top and bottom rails. Provide galvanized-steel bases for supporting posts.
- C. Polyethylene Sheet: Reinforced, fire-resistive sheet, 10-mil minimum thickness, with flame-spread rating of 15 or less per ASTM E 84 and passing NFPA 701 Test Method 2.

2.2 TEMPORARY FACILITIES

- A. Field Office located within the building: Of sufficient size to accommodate needs of Owner, Architect, Construction Manager, and construction personnel office activities and to accommodate Project meetings specified in other Division 01 Sections. Keep office clean and orderly. Furnish and equip offices as follows:
 1. Furniture required for Project-site documents including file cabinets, plan tables, plan racks, bookcases and table large enough for project meetings.

PART 3 - EXECUTION

3.1 TEMPORARY UTILITY INSTALLATION

- A. Sanitary Facilities: Provide temporary toilets, wash facilities, and drinking water for use of construction personnel.
- B. Heating and Cooling: Provide temporary heating and cooling required by construction activities for curing or drying of completed installations or for protecting installed construction from adverse effects of low temperatures or high humidity. Select equipment that will not have a harmful effect on completed installations or elements being installed.
- C. Ventilation and Humidity Control: Provide temporary ventilation required by construction activities for curing or drying of completed installations or for protecting installed construction from adverse effects of high humidity. Select equipment that will not have a harmful effect on completed installations or elements being installed. Coordinate ventilation requirements to produce ambient condition required and minimize energy consumption.
 - 1. Provide dehumidification systems when required to reduce substrate moisture levels to level required to allow installation or application of finishes.
- D. Electric Power Service: Connect to Owner's existing electric power service. Maintain equipment in a condition acceptable to Owner.
- E. Lighting: Provide temporary lighting with local switching that provides adequate illumination for construction operations, observations, inspections, and traffic conditions.
 - 1. Install and operate temporary lighting that fulfills security and protection requirements without operating entire system.

3.2 SUPPORT FACILITIES INSTALLATION

- A. Parking: Temporary parking areas are provided on site for construction personnel.
- B. Project Signs: Provide Project signs as indicated in this specification section and in the EDA Construction Site Sign Specifications. Unauthorized signs are not permitted.
 - 1. Identification Signs: Provide Project identification signs as indicated on Drawings or in the Project Manual. (See sample following this Section).
 - a. Size: 4' x 8' x 3/4"
 - b. Material: APA Rated A-B Grade - Exterior.
 - c. Framing: 2' x 4' PT framing nominal on four sides and center cross bracing.
 - d. Mounting: Mount sign to 4 x 4 post with four (4) 3/8" (min.) galvanized bolts with washers on each side of wood construction. Double nuts at back of sign.
 - e. Supports: Set 4' x 4' PT wood posts min. 3' into 12" dia. hole. Fill with concrete.
 - f. Paint: Face to receive three coats exterior enamel (sprayed). Back to receive 2 coats.
 - g. Colors: Architect to provide graphic.
 - h. Lettering: Silk Screen enamel. Lettering sizes and positioning as illustrated.
 - 2. Temporary Signs: Provide other signs as indicated and as required to inform public and individuals seeking entrance to Project.
 - 3. Maintain and touchup signs so they are legible at all times.

- C. Waste Disposal Facilities: Comply with requirements specified in Division 01 Section "Construction Waste Management and Disposal."

3.3 SECURITY AND PROTECTION FACILITIES INSTALLATION

- A. Protection of Existing Facilities: Protect existing vegetation, equipment, structures, utilities, and other improvements at Project site and on adjacent properties, except those indicated to be removed or altered. Repair damage to existing facilities.
- B. Environmental Protection: Provide protection, operate temporary facilities, and conduct construction as required to comply with environmental regulations and that minimize possible air, waterway, and subsoil contamination or pollution or other undesirable effects.
 - 1. Comply with work restrictions specified in Division 01 Section "Summary."
- C. Pest Control: Engage pest-control service to recommend practices to minimize attraction and harboring of rodents, roaches, and other pests and to perform extermination and control procedures at regular intervals so Project will be free of pests and their residues at Substantial Completion. Perform control operations lawfully, using environmentally safe materials.
- D. Site Enclosure Fence: Before construction operations begin, furnish and install site enclosure fence in a manner that will prevent people and animals from easily entering site except by entrance gates.
 - 1. Extent of Fence: As required to enclose entire Project site or portion determined sufficient to accommodate construction operations.
 - 2. Maintain security by limiting number of keys and restricting distribution to authorized personnel. Furnish one set of keys to Owner.
- E. Security Enclosure and Lockup: Install temporary enclosure around partially completed areas of construction. Provide lockable entrances to prevent unauthorized entrance, vandalism, theft, and similar violations of security. Lock entrances at end of each work day.

3.4 MOISTURE AND MOLD CONTROL

- A. Contractor's Moisture-Protection Plan: Avoid trapping water in finished work. Document visible signs of mold that may appear during construction.
- B. Exposed Construction Phase: Before installation of weather barriers, when materials are subject to wetting and exposure and to airborne mold spores, protect as follows:
 - 1. Protect porous materials from water damage.
 - 2. Protect stored and installed material from flowing or standing water.
 - 3. Keep porous and organic materials from coming into prolonged contact with concrete.
 - 4. Remove standing water from decks.
 - 5. Keep deck openings covered or dammed.
- C. Partially Enclosed Construction Phase: After installation of weather barriers but before full enclosure and conditioning of building, when installed materials are still subject to infiltration of moisture and ambient mold spores, protect as follows:
 - 1. Do not load or install drywall or other porous materials or components, or items with high organic content, into partially enclosed building.
 - 2. Keep interior spaces reasonably clean and protected from water damage.

3. Periodically collect and remove waste containing cellulose or other organic matter.
 4. Discard or replace water-damaged material.
 5. Do not install material that is wet.
 6. Discard, replace, or clean stored or installed material that begins to grow mold.
 7. Perform work in a sequence that allows any wet materials adequate time to dry before enclosing the material in drywall or other interior finishes.
- D. Controlled Construction Phase of Construction: After completing and sealing of the building enclosure but prior to the full operation of permanent HVAC systems, maintain as follows:
1. Control moisture and humidity inside building by maintaining effective dry-in conditions.
 2. Comply with manufacturer's written instructions for temperature, relative humidity, and exposure to water limits.
 - a. Hygroscopic materials that may support mold growth, including wood and gypsum-based products, that become wet during the course of construction and remain wet for 48 hours are considered defective.
 - b. Measure moisture content of materials that have been exposed to moisture during construction operations or after installation. Record readings beginning at time of exposure and continuing daily for 48 hours. Identify materials containing moisture levels higher than allowed. Report findings in writing to Architect.
 - c. Remove materials that can not be completely restored to their manufactured moisture level within 48 hours.

END OF SECTION 015000

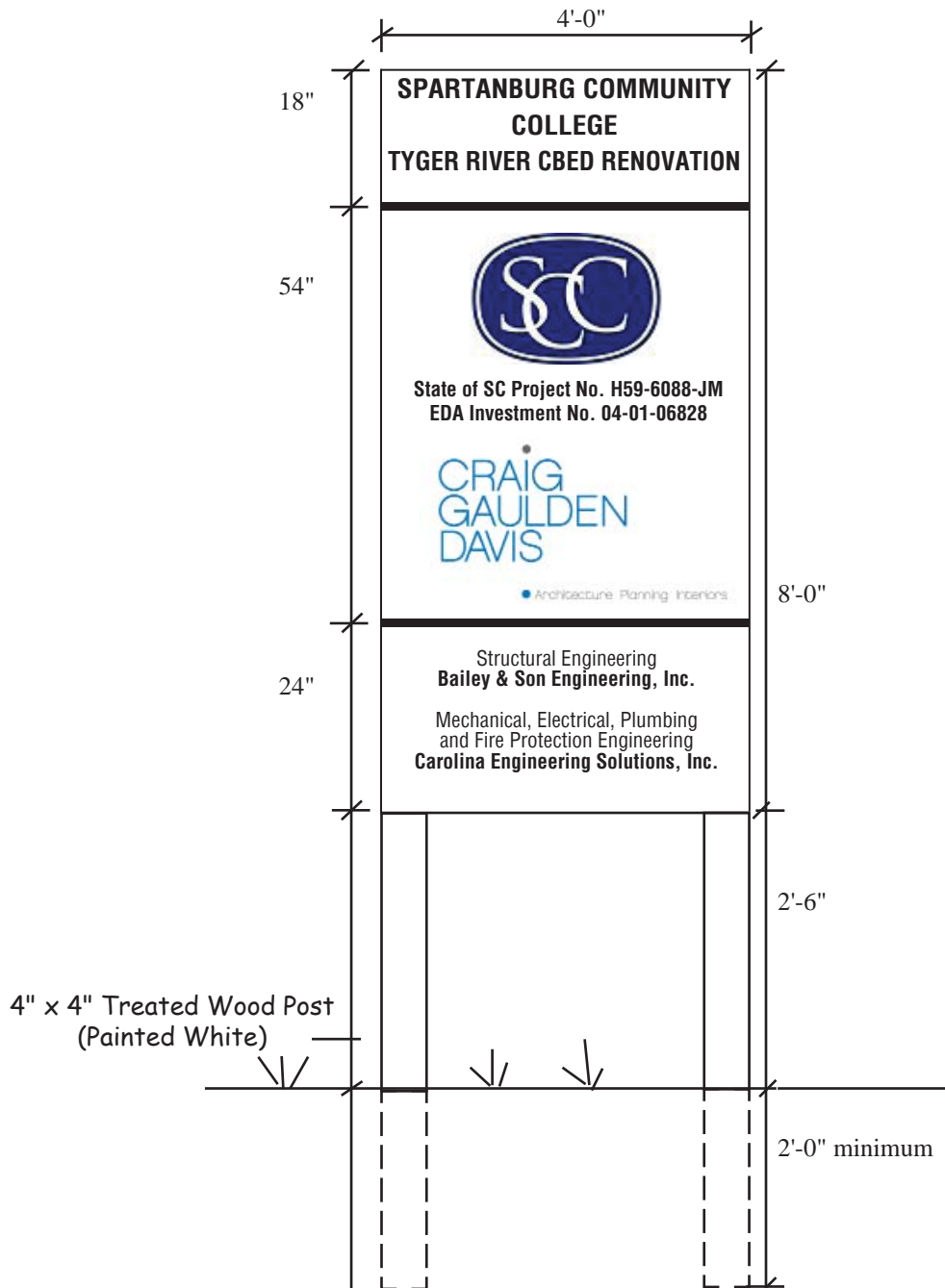

Typeface - Helvetica
CGD Blue - Pantone 3005
CGD Gray - Pantone 446

Scale: 1/2" = 1'-0"

Job Sign
Tyger River CBED Renovation
Spartanburg Community College -
Tyger River Campus
State of SC Project No. H59-6088-JM

SECTION 016000 - PRODUCT REQUIREMENTS

PART 1 - GENERAL

1.1 RELATED DOCUMENTS

- A. Drawings and general provisions of the Contract, including General and Supplementary Conditions and other Division 01 Specification Sections, apply to this Section.

1.2 SUMMARY

- A. Section includes administrative and procedural requirements for selection of products for use in Project; product delivery, storage, and handling; manufacturers' standard warranties on products; special warranties; and comparable products.

1.3 DEFINITIONS

- A. Products: Items obtained for incorporating into the Work, whether purchased for Project or taken from previously purchased stock. The term "product" includes the terms "material," "equipment," "system," and terms of similar intent.
 - 1. Named Products: Items identified by manufacturer's product name, including make or model number or other designation shown or listed in manufacturer's published product literature, that is current as of date of the Contract Documents.
 - 2. New Products: Items that have not previously been incorporated into another project or facility. Products salvaged or recycled from other projects are not considered new products.
 - 3. Comparable Product: Product that is demonstrated and approved through submittal process to have the indicated qualities related to type, function, dimension, in-service performance, physical properties, appearance, and other characteristics that equal or exceed those of specified product.
- B. Basis-of-Design Product Specification: A specification in which a specific manufacturer's product is named and accompanied by the words "basis-of-design product," including make or model number or other designation, to establish the significant qualities related to type, function, dimension, in-service performance, physical properties, appearance, and other characteristics for purposes of evaluating comparable products of additional manufacturers named in the specification.

1.4 ACTION SUBMITTALS

- A. Comparable Product Requests: Submit request for consideration of each comparable product. Identify product or fabrication or installation method to be replaced. Include Specification Section number and title and Drawing numbers and titles.
 - 1. Include data to indicate compliance with the requirements specified in "Comparable Products" Article.
 - 2. Architect's Action: If necessary, Architect will request additional information or documentation for evaluation within one week of receipt of a comparable product request. Architect will notify Contractor of approval or rejection of proposed comparable product request within 15 days of receipt of request, or seven days of receipt of additional information or documentation, whichever is later.

- a. Form of Approval: As specified in Division 01 Section "Submittal Procedures."
 - b. Use product specified if Architect does not issue a decision on use of a comparable product request within time allocated.
- B. Basis-of-Design Product Specification Submittal: Comply with requirements in Division 01 Section "Submittal Procedures." Show compliance with requirements.

1.5 QUALITY ASSURANCE

- A. Compatibility of Options: If Contractor is given option of selecting between two or more products for use on Project, select product compatible with products previously selected, even if previously selected products were also options.

1.6 PRODUCT DELIVERY, STORAGE, AND HANDLING

- A. Deliver, store, and handle products using means and methods that will prevent damage, deterioration, and loss, including theft and vandalism. Comply with manufacturer's written instructions.
- B. Delivery and Handling:
- 1. Schedule delivery to minimize long-term storage at Project site and to prevent overcrowding of construction spaces.
 - 2. Coordinate delivery with installation time to ensure minimum holding time for items that are flammable, hazardous, easily damaged, or sensitive to deterioration, theft, and other losses.
 - 3. Deliver products to Project site in an undamaged condition in manufacturer's original sealed container or other packaging system, complete with labels and instructions for handling, storing, unpacking, protecting, and installing.
 - 4. Inspect products on delivery to determine compliance with the Contract Documents and to determine that products are undamaged and properly protected.
- C. Storage:
- 1. Store products to allow for inspection and measurement of quantity or counting of units.
 - 2. Store materials in a manner that will not endanger Project structure.
 - 3. Store products that are subject to damage by the elements, under cover in a weathertight enclosure above ground, with ventilation adequate to prevent condensation.
 - 4. Protect foam plastic from exposure to sunlight, except to extent necessary for period of installation and concealment.
 - 5. Comply with product manufacturer's written instructions for temperature, humidity, ventilation, and weather-protection requirements for storage.
 - 6. Protect stored products from damage and liquids from freezing.

1.7 PRODUCT WARRANTIES

- A. Warranties specified in other Sections shall be in addition to, and run concurrent with, other warranties required by the Contract Documents. Manufacturer's disclaimers and limitations on product warranties do not relieve Contractor of obligations under requirements of the Contract Documents.
- 1. Manufacturer's Warranty: Written warranty furnished by individual manufacturer for a particular product and specifically endorsed by manufacturer to Owner.
 - 2. Special Warranty: Written warranty required by the Contract Documents to provide specific rights for Owner.

- B. Special Warranties: Prepare a written document that contains appropriate terms and identification, ready for execution.
 - 1. Manufacturer's Standard Form: Modified to include Project-specific information and properly executed.
 - 2. Specified Form: When specified forms are included with the Specifications, prepare a written document using indicated form properly executed.
 - 3. See Divisions 02 through 33 Sections for specific content requirements and particular requirements for submitting special warranties.
- C. Submittal Time: Comply with requirements in Division 01 Section "Closeout Procedures."

PART 2 - PRODUCTS

2.1 PRODUCT SELECTION PROCEDURES

- A. General Product Requirements: Provide products that comply with the Contract Documents, are undamaged and, unless otherwise indicated, are new at time of installation.
 - 1. Provide products complete with accessories, trim, finish, fasteners, and other items needed for a complete installation and indicated use and effect.
 - 2. Standard Products: If available, and unless custom products or nonstandard options are specified, provide standard products of types that have been produced and used successfully in similar situations on other projects.
 - 3. Where products are accompanied by the term "as selected," Architect will make selection.
 - 4. Descriptive, performance, and reference standard requirements in the Specifications establish salient characteristics of products.
- B. Product Selection Procedures:
 - 1. Products:
 - a. Nonrestricted List: Where Specifications include a list of names of both available manufacturers and products, provide one of the products listed, or an unnamed product, that complies with requirements. Comply with requirements in "Comparable Products" Article for consideration of an unnamed product.
 - 2. Manufacturers:
 - a. Nonrestricted List: Where Specifications include a list of available manufacturers, provide a product by one of the manufacturers listed, or a product by an unnamed manufacturer, that complies with requirements. Comply with requirements in "Comparable Products" Article for consideration of an unnamed manufacturer's product.
 - 3. Basis-of-Design Product: Where Specifications name a product, or refer to a product indicated on Drawings, and include a list of manufacturers, provide the specified or indicated product or a comparable product by one of the other named manufacturers. Drawings and Specifications indicate sizes, profiles, dimensions, and other characteristics that are based on the product named. Comply with requirements in "Comparable Products" Article for consideration of an unnamed product by one of the other named manufacturers.
- C. Visual Matching Specification: Where Specifications require "match Architect's sample", provide a product that complies with requirements and matches Architect's sample. Architect's decision will be final on whether a proposed product matches.

1. If no product available within specified category matches and complies with other specified requirements, comply with requirements in Division 01 Section "Substitution Procedures" for proposal of product.
- D. Visual Selection Specification: Where Specifications include the phrase "as selected by Architect from manufacturer's full range" or similar phrase, select a product that complies with requirements. Architect will select color, gloss, pattern, density, or texture from manufacturer's product line that includes both standard and premium items.
- 2.2 COMPARABLE PRODUCTS
- A. Conditions for Consideration: Architect will consider Contractor's request for comparable product when the following conditions are satisfied. If the following conditions are not satisfied, Architect may return requests without action, except to record noncompliance with these requirements:
1. Evidence that the proposed product does not require revisions to the Contract Documents, that it is consistent with the Contract Documents and will produce the indicated results, and that it is compatible with other portions of the Work.
 2. Detailed comparison of significant qualities of proposed product with those named in the Specifications. Significant qualities include attributes such as performance, weight, size, durability, visual effect, and specific features and requirements indicated.
 3. Evidence that proposed product provides specified warranty.
 4. List of similar installations for completed projects with project names and addresses and names and addresses of architects and owners, if requested.
 5. Samples, if requested.

PART 3 - EXECUTION (Not Used)

END OF SECTION 016000

PROPOSED SUBSTITUTION REQUEST FORM

To: _____

Project: _____

Architect's Project No.: _____

We hereby submit for your consideration the following product instead of the specified item for the above project:

DRAWING NO.	SPECIFICATION SECTION	PARAGRAPH	ITEM SPECIFIED
_____	_____	_____	_____

Proposed Substitution: _____

Manufacturer: _____

Attach complete information on proposed changes and/or to Drawings and/or Specifications which the proposed substitution will require for its proper installation.

Provide the length of time the manufacturer has been in business in the manufacturer of this product.

Submit with request all necessary samples, manufacturer's substantiating data, performance and test reports to prove equal quality and performance to the product that is specified. Clearly mark manufacturer's literature to indicate equality in performance to assist in the evaluation of the substitution by the Architect. Provide a written description of the proposed substitution and provide as an attachment to this request form.

The following supporting data is attached to this substitution:

- Drawings
- Performance & Test Reports
- Written Description
- Product Samples
- Samples
- Other

Complete the following:

1. Does the proposed substitution affect dimensions and or details shown on the Drawings? Yes No

If yes, clearly indicate the changes below or on an attached sheet.

2. Will the undersigned pay for any and all changes to the building design, including engineering and detailing costs caused by the requested substitution? Yes No

If no, fully explain:

3. Does the proposed substitution have any affect on other Contracts or other Trades? Yes No

If yes, fully explain: _____

4. Does the proposed substitution affect the construction schedule? Yes No

If yes, fully explain: _____

PROPOSED SUBSTITUTION REQUEST FORM

-
5. The differences between the warranties of the proposed substitution and specified items are:
Same _____ Different _____ (Explain on attachment.)
6. State the reason for the proposed substitution request: _____
-
7. Itemize the comparison of specified item(s) with the proposed substitution; list all variations:

8. Provide cost comparison between the proposed substitution and the product specified.

9. Provide a detail explanation as to why this substitution is a benefit to the Owner.

10. Will service and maintenance parts be readily available after installation is complete?

11. If it is determined that this proposed substitution does not comply with the contract documents after approval, will the undersigned agree to pay for the removal and reinstallation of one of the specified products.
- Yes
 - No
- If no, explain fully below:

PROPOSED SUBSTITUTION REQUEST FORM

The undersigned certifies that the proposed substitution has been fully investigated and the function, appearance and quality are equivalent or superior to the specified item.

Submitted By:

Name (Signature)

Name (Printed)

Title

Firm

Address

Telephone *Date*

Email Address

The person signing this substitution request form shall have authority to legally bind his firm to the terms listed above. The failure to provide a legally binding signature will result in the Architect's rejection of this proposed substitution.

Architect's Response:

- Accepted Accepted as Noted
 Not Accepted Received Too Late

By: _____

Date: _____

Remarks: _____

SECTION 017300 - EXECUTION

PART 1 - GENERAL

1.1 RELATED DOCUMENTS

- A. Drawings and general provisions of the Contract, including General and Supplementary Conditions and other Division 01 Specification Sections, apply to this Section.

1.2 SUMMARY

- A. Section includes general administrative and procedural requirements governing execution of the Work including, but not limited to, the following:
 - 1. Construction layout.
 - 2. Field engineering and surveying.
 - 3. Installation of the Work.
 - 4. Cutting and patching.
 - 5. Coordination of Owner-installed products.
 - 6. Progress cleaning.
 - 7. Starting and adjusting.
 - 8. Protection of installed construction.
 - 9. Correction of the Work.

1.3 DEFINITIONS

- A. Cutting: Removal of in-place construction necessary to permit installation or performance of other work.
- B. Patching: Fitting and repair work required to restore construction to original conditions after installation of other work.

1.4 INFORMATIONAL SUBMITTALS

- A. Qualification Data: For land surveyor.
- B. Certificates: Submit certificate signed by land surveyor certifying that location and elevation of improvements comply with requirements.
- C. Certified Surveys: Submit two copies signed by land surveyor.

1.5 QUALITY ASSURANCE

- A. Land Surveyor Qualifications: A professional land surveyor who is legally qualified to practice in jurisdiction where Project is located and who is experienced in providing land-surveying services of the kind indicated.
- B. Cutting and Patching: Comply with requirements for and limitations on cutting and patching of construction elements.

1. Structural Elements: When cutting and patching structural elements, notify Architect of locations and details of cutting and await directions from Architect before proceeding. Shore, brace, and support structural elements during cutting and patching. Do not cut and patch structural elements in a manner that could change their load-carrying capacity or increase deflection
 2. Operational Elements: Do not cut and patch operating elements and related components in a manner that results in reducing their capacity to perform as intended or that results in increased maintenance or decreased operational life or safety. Operational elements include the following:
 - a. Primary operational systems and equipment.
 - b. Fire separation assemblies.
 - c. Air or smoke barriers.
 - d. Fire-suppression systems.
 - e. Mechanical systems piping and ducts.
 - f. Control systems.
 - g. Communication systems.
 - h. Fire-detection and -alarm systems.
 - i. Electrical wiring systems.
 - j. .
 3. Other Construction Elements: Do not cut and patch other construction elements or components in a manner that could change their load-carrying capacity, that results in reducing their capacity to perform as intended, or that results in increased maintenance or decreased operational life or safety. Other construction elements include but are not limited to the following:
 - a. Water, moisture, or vapor barriers.
 - b. Membranes and flashings.
 - c. Exterior curtain-wall construction.
 - d. Sprayed fire-resistive material.
 - e. Equipment supports.
 - f. Piping, ductwork, vessels, and equipment.
 - g. Noise- and vibration-control elements and systems.
 4. Visual Elements: Do not cut and patch construction in a manner that results in visual evidence of cutting and patching. Do not cut and patch exposed construction in a manner that would, in Architect's opinion, reduce the building's aesthetic qualities. Remove and replace construction that has been cut and patched in a visually unsatisfactory manner.
- C. Manufacturer's Installation Instructions: Obtain and maintain on-site manufacturer's written recommendations and instructions for installation of products and equipment.

PART 2 - PRODUCTS

2.1 MATERIALS

- A. General: Comply with requirements specified in other Sections.
 1. For projects requiring compliance with sustainable design and construction practices and procedures, use products for patching that comply with requirements in Division 01 sustainable design requirements Section.
- B. In-Place Materials: Use materials for patching identical to in-place materials. For exposed surfaces, use materials that visually match in-place adjacent surfaces to the fullest extent possible.

EXECUTION

1. If identical materials are unavailable or cannot be used, use materials that, when installed, will provide a match acceptable to Architect for the visual and functional performance of in-place materials.

PART 3 - EXECUTION

3.1 EXAMINATION

- A. Existing Conditions: The existence and location of underground and other utilities and construction indicated as existing are not guaranteed. Before beginning sitework, investigate and verify the existence and location of underground utilities, mechanical and electrical systems, and other construction affecting the Work.
 1. Before construction, verify the location and invert elevation at points of connection of sanitary sewer, storm sewer, and water-service piping; underground electrical services, and other utilities.
 2. Furnish location data for work related to Project that must be performed by public utilities serving Project site.
- B. Examination and Acceptance of Conditions: Before proceeding with each component of the Work, examine substrates, areas, and conditions, with Installer or Applicator present where indicated, for compliance with requirements for installation tolerances and other conditions affecting performance. Record observations.
 1. Examine roughing-in for mechanical and electrical systems to verify actual locations of connections before equipment and fixture installation.
 2. Examine walls, floors, and roofs for suitable conditions where products and systems are to be installed.
 3. Verify compatibility with and suitability of substrates, including compatibility with existing finishes or primers.
- C. Proceed with installation only after unsatisfactory conditions have been corrected. Proceeding with the Work indicates acceptance of surfaces and conditions.

3.2 PREPARATION

- A. Field Measurements: Take field measurements as required to fit the Work properly. Recheck measurements before installing each product. Where portions of the Work are indicated to fit to other construction, verify dimensions of other construction by field measurements before fabrication. Coordinate fabrication schedule with construction progress to avoid delaying the Work.
- B. Space Requirements: Verify space requirements and dimensions of items shown diagrammatically on Drawings.
- C. Review of Contract Documents and Field Conditions: Immediately on discovery of the need for clarification of the Contract Documents caused by differing field conditions outside the control of Contractor, submit a request for information to Architect according to requirements in Division 01 Section "Project Management and Coordination."

3.3 CONSTRUCTION LAYOUT

- A. Verification: Before proceeding to lay out the Work, verify layout information shown on Drawings, in relation to the property survey and existing benchmarks. If discrepancies are discovered, notify Architect promptly.

EXECUTION

- B. General: Engage a land surveyor to lay out the Work using accepted surveying practices.
 - 1. Establish benchmarks and control points to set lines and levels at each story of construction and elsewhere as needed to locate each element of Project.
 - 2. Establish limits on use of Project site.
 - 3. Establish dimensions within tolerances indicated. Do not scale Drawings to obtain required dimensions.
 - 4. Inform installers of lines and levels to which they must comply.
 - 5. Check the location, level and plumb, of every major element as the Work progresses.
 - 6. Notify Architect when deviations from required lines and levels exceed allowable tolerances.
 - 7. Close site surveys with an error of closure equal to or less than the standard established by authorities having jurisdiction.
- C. Site Improvements: Locate and lay out site improvements, including pavements, grading, fill and topsoil placement, utility slopes, and rim and invert elevations.
- D. Building Lines and Levels: Locate and lay out control lines and levels for structures, building foundations, column grids, and floor levels, including those required for mechanical and electrical work. Transfer survey markings and elevations for use with control lines and levels. Level foundations and piers from two or more locations.
- E. Record Log: Maintain a log of layout control work. Record deviations from required lines and levels. Include beginning and ending dates and times of surveys, weather conditions, name and duty of each survey party member, and types of instruments and tapes used. Make the log available for reference by Architect.

3.4 FIELD ENGINEERING

- A. Reference Points: Locate existing permanent benchmarks, control points, and similar reference points before beginning the Work. Preserve and protect permanent benchmarks and control points during construction operations.
 - 1. Do not change or relocate existing benchmarks or control points without prior written approval of Architect. Report lost or destroyed permanent benchmarks or control points promptly. Report the need to relocate permanent benchmarks or control points to Architect before proceeding.

3.5 INSTALLATION

- A. General: Locate the Work and components of the Work accurately, in correct alignment and elevation, as indicated.
 - 1. Make vertical work plumb and make horizontal work level.
 - 2. Where space is limited, install components to maximize space available for maintenance and ease of removal for replacement.
 - 3. Conceal pipes, ducts, and wiring in finished areas unless otherwise indicated.
 - 4. Maintain minimum headroom clearance of 96 inches in occupied spaces and 90 inches in unoccupied spaces.
- B. Comply with manufacturer's written instructions and recommendations for installing products in applications indicated.
- C. Install products at the time and under conditions that will ensure the best possible results. Maintain conditions required for product performance until Substantial Completion.

- D. Conduct construction operations so no part of the Work is subjected to damaging operations or loading in excess of that expected during normal conditions of occupancy.
- E. Sequence the Work and allow adequate clearances to accommodate movement of construction items on site and placement in permanent locations.
- F. Tools and Equipment: Do not use tools or equipment that produce harmful noise levels.
- G. Templates: Obtain and distribute to the parties involved templates for work specified to be factory prepared and field installed. Check Shop Drawings of other work to confirm that adequate provisions are made for locating and installing products to comply with indicated requirements.
- H. Attachment: Provide blocking and attachment plates and anchors and fasteners of adequate size and number to securely anchor each component in place, accurately located and aligned with other portions of the Work. Where size and type of attachments are not indicated, verify size and type required for load conditions.
 - 1. Mounting Heights: Where mounting heights are not indicated, mount components at heights directed by Architect.
 - 2. Allow for building movement, including thermal expansion and contraction.
 - 3. Coordinate installation of anchorages. Furnish setting drawings, templates, and directions for installing anchorages, including sleeves, concrete inserts, anchor bolts, and items with integral anchors, that are to be embedded in concrete or masonry. Deliver such items to Project site in time for installation.
- I. Joints: Make joints of uniform width. Where joint locations in exposed work are not indicated, arrange joints for the best visual effect. Fit exposed connections together to form hairline joints.
- J. Hazardous Materials: Use products, cleaners, and installation materials that are not considered hazardous.

3.6 CUTTING AND PATCHING

- A. Cutting and Patching, General: Employ skilled workers to perform cutting and patching. Proceed with cutting and patching at the earliest feasible time, and complete without delay.
 - 1. Cut in-place construction to provide for installation of other components or performance of other construction, and subsequently patch as required to restore surfaces to their original condition.
- B. Existing Warranties: Remove, replace, patch, and repair materials and surfaces cut or damaged during installation or cutting and patching operations, by methods and with materials so as not to void existing warranties.
- C. Temporary Support: Provide temporary support of work to be cut.
- D. Protection: Protect in-place construction during cutting and patching to prevent damage. Provide protection from adverse weather conditions for portions of Project that might be exposed during cutting and patching operations.
- E. Adjacent Occupied Areas: Where interference with use of adjoining areas or interruption of free passage to adjoining areas is unavoidable, coordinate cutting and patching according to requirements in Division 01 Section "Summary."
- F. Existing Utility Services and Mechanical/Electrical Systems: Where existing services/systems are required to be removed, relocated, or abandoned, bypass such services/systems before cutting to prevent interruption to occupied areas.

- G. Cutting: Cut in-place construction by sawing, drilling, breaking, chipping, grinding, and similar operations, including excavation, using methods least likely to damage elements retained or adjoining construction. If possible, review proposed procedures with original Installer; comply with original Installer's written recommendations.
1. In general, use hand or small power tools designed for sawing and grinding, not hammering and chopping. Cut holes and slots neatly to minimum size required, and with minimum disturbance of adjacent surfaces. Temporarily cover openings when not in use.
 2. Finished Surfaces: Cut or drill from the exposed or finished side into concealed surfaces.
 3. Concrete and Masonry: Cut using a cutting machine, such as an abrasive saw or a diamond-core drill.
 4. Excavating and Backfilling: Comply with requirements in applicable Division 31 Sections where required by cutting and patching operations.
 5. Mechanical and Electrical Services: Cut off pipe or conduit in walls or partitions to be removed. Cap, valve, or plug and seal remaining portion of pipe or conduit to prevent entrance of moisture or other foreign matter after cutting.
 6. Proceed with patching after construction operations requiring cutting are complete.
- H. Patching: Patch construction by filling, repairing, refinishing, closing up, and similar operations following performance of other work. Patch with durable seams that are as invisible as practicable. Provide materials and comply with installation requirements specified in other Sections, where applicable.
1. Inspection: Where feasible, test and inspect patched areas after completion to demonstrate physical integrity of installation.
 2. Exposed Finishes: Restore exposed finishes of patched areas and extend finish restoration into retained adjoining construction in a manner that will minimize evidence of patching and refinishing.
 - a. Clean piping, conduit, and similar features before applying paint or other finishing materials.
 - b. Restore damaged pipe covering to its original condition.
 3. Floors and Walls: Where walls or partitions that are removed extend one finished area into another, patch and repair floor and wall surfaces in the new space. Provide an even surface of uniform finish, color, texture, and appearance. Remove in-place floor and wall coverings and replace with new materials, if necessary, to achieve uniform color and appearance.
 - a. Where patching occurs in a painted surface, prepare substrate and apply primer and intermediate paint coats appropriate for substrate over the patch, and apply final paint coat over entire unbroken surface containing the patch. Provide additional coats until patch blends with adjacent surfaces.
 4. Ceilings: Patch, repair, or rehang in-place ceilings as necessary to provide an even-plane surface of uniform appearance.
 5. Exterior Building Enclosure: Patch components in a manner that restores enclosure to a weathertight condition and ensures thermal and moisture integrity of building enclosure.
- I. Cleaning: Clean areas and spaces where cutting and patching are performed. Remove paint, mortar, oils, putty, and similar materials from adjacent finished surfaces.

3.7 OWNER-INSTALLED PRODUCTS

- A. Site Access: Provide access to Project site for Owner's construction personnel.
- B. Coordination: Coordinate construction and operations of the Work with work performed by Owner's construction personnel.

1. Construction Schedule: Inform Owner of Contractor's preferred construction schedule for Owner's portion of the Work. Adjust construction schedule based on a mutually agreeable timetable. Notify Owner if changes to schedule are required due to differences in actual construction progress.
2. Preinstallation Conferences: Include Owner's construction personnel at preinstallation conferences covering portions of the Work that are to receive Owner's work. Attend preinstallation conferences conducted by Owner's construction personnel if portions of the Work depend on Owner's construction.

3.8 PROGRESS CLEANING

- A. General: Clean Project site and work areas daily, including common areas. Enforce requirements strictly. Dispose of materials lawfully.
 1. Comply with requirements in NFPA 241 for removal of combustible waste materials and debris.
 2. Do not hold waste materials more than seven days during normal weather or three days if the temperature is expected to rise above 80 deg F.
 3. Containerize hazardous and unsanitary waste materials separately from other waste. Mark containers appropriately and dispose of legally, according to regulations.
 - a. Use containers intended for holding waste materials of type to be stored.
 4. Coordinate progress cleaning for joint-use areas where Contractor and other contractors are working concurrently.
- B. Site: Maintain Project site free of waste materials and debris.
- C. Work Areas: Clean areas where work is in progress to the level of cleanliness necessary for proper execution of the Work.
 1. Remove liquid spills promptly.
 2. Where dust would impair proper execution of the Work, broom-clean or vacuum the entire work area, as appropriate.
- D. Installed Work: Keep installed work clean. Clean installed surfaces according to written instructions of manufacturer or fabricator of product installed, using only cleaning materials specifically recommended. If specific cleaning materials are not recommended, use cleaning materials that are not hazardous to health or property and that will not damage exposed surfaces.
- E. Concealed Spaces: Remove debris from concealed spaces before enclosing the space.
- F. Exposed Surfaces in Finished Areas: Clean exposed surfaces and protect as necessary to ensure freedom from damage and deterioration at time of Substantial Completion.
- G. Waste Disposal: Do not bury or burn waste materials on-site. Do not wash waste materials down sewers or into waterways. Comply with waste disposal requirements in Division 01 Section "Construction Waste Management and Disposal."
- H. During handling and installation, clean and protect construction in progress and adjoining materials already in place. Apply protective covering where required to ensure protection from damage or deterioration at Substantial Completion.
- I. Clean and provide maintenance on completed construction as frequently as necessary through the remainder of the construction period. Adjust and lubricate operable components to ensure operability without damaging effects.

- J. Limiting Exposures: Supervise construction operations to assure that no part of the construction, completed or in progress, is subject to harmful, dangerous, damaging, or otherwise deleterious exposure during the construction period.

3.9 STARTING AND ADJUSTING

- A. Coordinate startup and adjusting of equipment and operating components with requirements in Division 01 Section "General Commissioning Requirements."
- B. Start equipment and operating components to confirm proper operation. Remove malfunctioning units, replace with new units, and retest.
- C. Adjust equipment for proper operation. Adjust operating components for proper operation without binding.
- D. Test each piece of equipment to verify proper operation. Test and adjust controls and safeties. Replace damaged and malfunctioning controls and equipment.
- E. Manufacturer's Field Service: Comply with qualification requirements in Division 01 Section "Quality Requirements."

3.10 PROTECTION OF INSTALLED CONSTRUCTION

- A. Provide final protection and maintain conditions that ensure installed Work is without damage or deterioration at time of Substantial Completion.
- B. Comply with manufacturer's written instructions for temperature and relative humidity.

END OF SECTION 017300

SECTION 017700 - CLOSEOUT PROCEDURES

PART 1 - GENERAL

1.1 RELATED DOCUMENTS

- A. Drawings and general provisions of the Contract, including General and Supplementary Conditions and other Division 01 Specification Sections, apply to this Section.

1.2 SUMMARY

- A. Section includes administrative and procedural requirements for contract closeout, including, but not limited to, the following:
 - 1. Substantial Completion procedures.
 - 2. Final completion procedures.
 - 3. Warranties.
 - 4. Final cleaning.
 - 5. Repair of the Work.

1.3 ACTION SUBMITTALS

- A. Product Data: For cleaning agents.

1.4 MAINTENANCE MATERIAL SUBMITTALS

- A. Schedule of Maintenance Material Items: For maintenance material submittal items specified in other Sections.

1.5 SUBSTANTIAL COMPLETION PROCEDURES

- A. Contractor's List of Incomplete Items: Prepare and submit a list of items to be completed and corrected (Contractor's punch list), indicating the value of each item on the list and reasons why the Work is incomplete.
- B. Submittals Prior to Substantial Completion: Complete the following a minimum of 10 days prior to requesting inspection for determining date of Substantial Completion. List items below that are incomplete at time of request.
 - 1. Submit closeout submittals specified in other Division 01 Sections, including project record documents, operation and maintenance manuals, final completion construction photographic documentation, damage or settlement surveys, property surveys, and similar final record information.
 - 2. Submit closeout submittals specified in individual Divisions 02 through 33 Sections, including specific warranties, workmanship bonds, maintenance service agreements, final certifications, and similar documents.
 - 3. Submit maintenance material submittals specified in individual Divisions 02 through 33 Sections, including tools, spare parts, extra materials, and similar items, and deliver to location designated by Architect. Label with manufacturer's name and model number where applicable.

- a. Schedule of Maintenance Material Items: Prepare and submit schedule of maintenance material submittal items, including name and quantity of each item and name and number of related Specification Section. Obtain signature for receipt of submittals.
 4. Submit test/adjust/balance records.
 5. Submit sustainable design submittals required in Division 01 sustainable design requirements Section and in individual Division 02 through 33 Sections.
 6. Submit changeover information related to Owner's occupancy, use, operation, and maintenance.
- C. Procedures Prior to Substantial Completion: Complete the following a minimum of 10 days prior to requesting inspection for determining date of Substantial Completion. List items below that are incomplete at time of request.
1. Advise Owner of pending insurance changeover requirements.
 2. Make final changeover of permanent locks and deliver keys to Owner. Advise Owner's personnel of changeover in security provisions.
 3. Complete startup and testing of systems and equipment.
 4. Perform preventive maintenance on equipment used prior to Substantial Completion.
 5. Instruct Owner's personnel in operation, adjustment, and maintenance of products, equipment, and systems. Submit demonstration and training video recordings specified in Division 01 Section "Demonstration and Training."
 6. Advise Owner of changeover in heat and other utilities.
 7. Participate with Owner in conducting inspection and walkthrough with local emergency responders.
 8. Terminate and remove temporary facilities from Project site, along with mockups, construction tools, and similar elements.
 9. Complete final cleaning requirements, including touchup painting.
 10. Touch up and otherwise repair and restore marred exposed finishes to eliminate visual defects.
- D. Inspection: Submit a written request for inspection to determine Substantial Completion a minimum of 10 days prior to date the work will be completed and ready for final inspection and tests. On receipt of request, Architect will either proceed with inspection or notify Contractor of unfulfilled requirements. Architect will prepare the Certificate of Substantial Completion after inspection or will notify Contractor of items, either on Contractor's list or additional items identified by Architect, that must be completed or corrected before certificate will be issued.
1. Reinspection: Request reinspection when the Work identified in previous inspections as incomplete is completed or corrected.
 2. Results of completed inspection will form the basis of requirements for final completion.

1.6 FINAL COMPLETION PROCEDURES

- A. Submittals Prior to Final Completion: Before requesting final inspection for determining final completion, complete the following:
1. Submit a final Application for Payment according to Division 01 Section "Payment Procedures."
 2. Certified List of Incomplete Items: Submit certified copy of Architect's Substantial Completion inspection list of items to be completed or corrected (punch list), endorsed and dated by Architect. Certified copy of the list shall state that each item has been completed or otherwise resolved for acceptance.
 3. Certificate of Insurance: Submit evidence of final, continuing insurance coverage complying with insurance requirements.
 4. Submit pest-control final inspection report.

- B. Inspection: Submit a written request for final inspection to determine acceptance a minimum of 10 days prior to date the work will be completed and ready for final inspection and tests. On receipt of request, Architect will either proceed with inspection or notify Contractor of unfulfilled requirements. Architect will prepare a final Certificate for Payment after inspection or will notify Contractor of construction that must be completed or corrected before certificate will be issued.
 - 1. Reinspection: Request reinspection when the Work identified in previous inspections as incomplete is completed or corrected.

1.7 LIST OF INCOMPLETE ITEMS (PUNCH LIST)

- A. Organization of List: Include name and identification of each space and area affected by construction operations for incomplete items and items needing correction including, if necessary, areas disturbed by Contractor that are outside the limits of construction.
 - 1. Organize list of spaces in sequential order, starting with exterior areas first.
 - 2. Organize items applying to each space by major element, including categories for ceiling, individual walls, floors, equipment, and building systems.
 - 3. Include the following information at the top of each page:
 - a. Project name.
 - b. Date.
 - c. Name of Architect.
 - d. Name of Contractor.
 - e. Page number.
 - 4. Submit list of incomplete items in the following format:
 - a. MS Excel electronic file. Architect will return annotated file.

1.8 SUBMITTAL OF PROJECT WARRANTIES

- A. Time of Submittal: Submit written warranties on request of Architect for designated portions of the Work where commencement of warranties other than date of Substantial Completion is indicated, or when delay in submittal of warranties might limit Owner's rights under warranty.
- B. Organize warranty documents into an orderly sequence based on the table of contents of Project Manual.
 - 1. Bind warranties and bonds in heavy-duty, three-ring, vinyl-covered, loose-leaf binders, thickness as necessary to accommodate contents, and sized to receive 8-1/2-by-11-inch paper.
 - 2. Provide heavy paper dividers with plastic-covered tabs for each separate warranty. Mark tab to identify the product or installation. Provide a typed description of the product or installation, including the name of the product and the name, address, and telephone number of Installer.
 - 3. Identify each binder on the front and spine with the typed or printed title "WARRANTIES," Project name, and name of Contractor.
 - 4. Warranty Electronic File: Scan warranties and bonds and assemble complete warranty and bond submittal package into a single indexed electronic PDF file with links enabling navigation to each item. Provide bookmarked table of contents at beginning of document.
- C. Provide additional copies of each warranty to include in operation and maintenance manuals.

PART 2 - PRODUCTS

2.1 MATERIALS

- A. Cleaning Agents: Use cleaning materials and agents recommended by manufacturer or fabricator of the surface to be cleaned. Do not use cleaning agents that are potentially hazardous to health or property or that might damage finished surfaces.

PART 3 - EXECUTION

3.1 FINAL CLEANING

- A. General: Perform final cleaning. Conduct cleaning and waste-removal operations to comply with local laws and ordinances and Federal and local environmental and antipollution regulations.
- B. Cleaning: Employ experienced workers or professional cleaners for final cleaning. Clean each surface or unit to condition expected in an average commercial building cleaning and maintenance program. Comply with manufacturer's written instructions.
 - 1. Complete the following cleaning operations before requesting inspection for certification of Substantial Completion for entire Project or for a designated portion of Project:
 - a. Clean Project site, yard, and grounds, in areas disturbed by construction activities, including landscape development areas, of rubbish, waste material, litter, and other foreign substances.
 - b. Sweep paved areas broom clean. Remove petrochemical spills, stains, and other foreign deposits.
 - c. Rake grounds that are neither planted nor paved to a smooth, even-textured surface.
 - d. Remove tools, construction equipment, machinery, and surplus material from Project site.
 - e. Remove snow and ice to provide safe access to building.
 - f. Clean exposed exterior and interior hard-surfaced finishes to a dirt-free condition, free of stains, films, and similar foreign substances. Avoid disturbing natural weathering of exterior surfaces. Restore reflective surfaces to their original condition.
 - g. Remove debris and surface dust from limited access spaces, including roofs, plenums, shafts, trenches, equipment vaults, manholes, attics, and similar spaces.
 - h. Sweep concrete floors broom clean in unoccupied spaces.
 - i. Vacuum carpet and similar soft surfaces, removing debris and excess nap; clean according to manufacturer's recommendations if visible soil or stains remain.
 - j. Clean transparent materials, including mirrors and glass in doors and windows. Remove glazing compounds and other noticeable, vision-obscuring materials. Polish mirrors and glass, taking care not to scratch surfaces.
 - k. Remove labels that are not permanent.
 - l. Wipe surfaces of mechanical and electrical equipment, elevator equipment, and similar equipment. Remove excess lubrication, paint and mortar droppings, and other foreign substances.
 - m. Clean plumbing fixtures to a sanitary condition, free of stains, including stains resulting from water exposure.
 - n. Replace disposable air filters and clean permanent air filters. Clean exposed surfaces of diffusers, registers, and grills.
 - o. Clean light fixtures, lamps, globes, and reflectors to function with full efficiency.
 - p. Leave Project clean and ready for occupancy.

- C. Pest Control: Comply with pest control requirements in Division 01 Section "Temporary Facilities and Controls." Prepare written report.
- D. Construction Waste Disposal: Comply with waste disposal requirements in Division 01 Section "Construction Waste Management and Disposal."

3.2 REPAIR OF THE WORK

- A. Complete repair and restoration operations before requesting inspection for determination of Substantial Completion.
- B. Repair or remove and replace defective construction. Repairing includes replacing defective parts, refinishing damaged surfaces, touching up with matching materials, and properly adjusting operating equipment. Where damaged or worn items cannot be repaired or restored, provide replacements. Remove and replace operating components that cannot be repaired. Restore damaged construction and permanent facilities used during construction to specified condition.
 - 1. Remove and replace chipped, scratched, and broken glass, reflective surfaces, and other damaged transparent materials.
 - 2. Touch up and otherwise repair and restore marred or exposed finishes and surfaces. Replace finishes and surfaces that that already show evidence of repair or restoration.
 - a. Do not paint over "UL" and other required labels and identification, including mechanical and electrical nameplates. Remove paint applied to required labels and identification.
 - 3. Replace parts subject to operating conditions during construction that may impede operation or reduce longevity.
 - 4. Replace burned-out bulbs, bulbs noticeably dimmed by hours of use, and defective and noisy starters in fluorescent and mercury vapor fixtures to comply with requirements for new fixtures.

END OF SECTION 017700

SECTION 017823 - OPERATION AND MAINTENANCE DATA

PART 1 - GENERAL

1.1 RELATED DOCUMENTS

- A. Drawings and general provisions of the Contract, including General and Supplementary Conditions and other Division 01 Specification Sections, apply to this Section.

1.2 SUMMARY

- A. Section includes administrative and procedural requirements for preparing operation and maintenance manuals, including the following:
 - 1. Operation and maintenance documentation directory.
 - 2. Product maintenance manuals.

1.3 DEFINITIONS

- A. System: An organized collection of parts, equipment, or subsystems united by regular interaction.
- B. Subsystem: A portion of a system with characteristics similar to a system.

1.4 CLOSEOUT SUBMITTALS

- A. Manual Content: Operations and maintenance manual content is specified in individual Specification Sections to be reviewed at the time of Section submittals. Submit reviewed manual content formatted and organized as required by this Section.
 - 1. Architect will comment on whether content of operations and maintenance submittals are acceptable.
 - 2. Where applicable, clarify and update reviewed manual content to correspond to revisions and field conditions.
- B. Format: Submit operations and maintenance manuals in the following format:
 - 1. Five (5) paper copies. Include a complete operation and maintenance directory. Enclose title pages and directories in clear plastic sleeves. Architect will return four (4) copies.
- C. Initial Manual Submittal: Submit draft copy of each manual at least 30 days before commencing demonstration and training. Architect will comment on whether general scope and content of manual are acceptable.
- D. Final Manual Submittal: Submit each manual in final form prior to requesting inspection for Substantial Completion and at least 15 days before commencing demonstration and training. Architect and Commissioning Authority will return copy with comments.
 - 1. Correct or revise each manual to comply with Architect's comments. Submit copies of each corrected manual within 15 days of receipt of Architect's and Commissioning Authority's comments and prior to commencing demonstration and training.

PART 2 - PRODUCTS

2.1 OPERATION AND MAINTENANCE DOCUMENTATION DIRECTORY

- A. Directory: Prepare a single, comprehensive directory of emergency, operation, and maintenance data and materials, listing items and their location to facilitate ready access to desired information. Include a section in the directory for each of the following:
 - 1. List of documents.
 - 2. List of systems.
 - 3. List of equipment.
 - 4. Table of contents.
- B. List of Systems and Subsystems: List systems alphabetically. Include references to operation and maintenance manuals that contain information about each system.
- C. List of Equipment: List equipment for each system, organized alphabetically by system. For pieces of equipment not part of system, list alphabetically in separate list.
- D. Tables of Contents: Include a table of contents for each emergency, operation, and maintenance manual.
- E. Identification: In the documentation directory and in each operation and maintenance manual, identify each system, subsystem, and piece of equipment with same designation used in the Contract Documents. If no designation exists, assign a designation according to ASHRAE Guideline 4, "Preparation of Operating and Maintenance Documentation for Building Systems."

2.2 REQUIREMENTS FOR EMERGENCY, OPERATION, AND MAINTENANCE MANUALS

- A. Organization: Unless otherwise indicated, organize each manual into a separate section for each system and subsystem, and a separate section for each piece of equipment not part of a system. Each manual shall contain the following materials, in the order listed:
 - 1. Title page.
 - 2. Table of contents.
 - 3. Manual contents.
- B. Title Page: Include the following information:
 - 1. Subject matter included in manual.
 - 2. Name and address of Project.
 - 3. Name and address of Owner.
 - 4. Date of submittal.
 - 5. Name and contact information for Contractor.
 - 6. Name and contact information for Architect.
 - 7. Names and contact information for major consultants to the Architect that designed the systems contained in the manuals.
 - 8. Cross-reference to related systems in other operation and maintenance manuals.
- C. Table of Contents: List each product included in manual, identified by product name, indexed to the content of the volume, and cross-referenced to Specification Section number in Project Manual.
 - 1. If operation or maintenance documentation requires more than one volume to accommodate data, include comprehensive table of contents for all volumes in each volume of the set.

- D. Manual Contents: Organize into sets of manageable size. Arrange contents alphabetically by system, subsystem, and equipment. If possible, assemble instructions for subsystems, equipment, and components of one system into a single binder.
- E. Manuals, Electronic Files: Submit manuals in the form of a multiple file composite electronic PDF file for each manual type required.
 - 1. Electronic Files: Use electronic files prepared by manufacturer where available. Where scanning of paper documents is required, configure scanned file for minimum readable file size.
 - 2. File Names and Bookmarks: Enable bookmarking of individual documents based on file names. Name document files to correspond to system, subsystem, and equipment names used in manual directory and table of contents. Group documents for each system and subsystem into individual composite bookmarked files, then create composite manual, so that resulting bookmarks reflect the system, subsystem, and equipment names in a readily navigated file tree. Configure electronic manual to display bookmark panel on opening file.
- F. Manuals, Paper Copy: Submit manuals in the form of hard copy, bound and labeled volumes.
 - 1. Binders: Heavy-duty, three-ring, vinyl-covered, loose-leaf binders, in thickness necessary to accommodate contents, sized to hold 8-1/2-by-11-inch paper; with clear plastic sleeve on spine to hold label describing contents and with pockets inside covers to hold folded oversize sheets.
 - a. If two or more binders are necessary to accommodate data of a system, organize data in each binder into groupings by subsystem and related components. Cross-reference other binders if necessary to provide essential information for proper operation or maintenance of equipment or system.
 - b. Identify each binder on front and spine, with printed title "OPERATION AND MAINTENANCE MANUAL," Project title or name, and subject matter of contents, and indicate Specification Section number on bottom of spine. Indicate volume number for multiple-volume sets.
 - 2. Dividers: Heavy-paper dividers with plastic-covered tabs for each section of the manual. Mark each tab to indicate contents. Include typed list of products and major components of equipment included in the section on each divider, cross-referenced to Specification Section number and title of Project Manual.
 - 3. Protective Plastic Sleeves: Transparent plastic sleeves designed to enclose diagnostic software storage media for computerized electronic equipment.
 - 4. Supplementary Text: Prepared on 8-1/2-by-11-inch white bond paper.
 - 5. Drawings: Attach reinforced, punched binder tabs on drawings and bind with text.
 - a. If oversize drawings are necessary, fold drawings to same size as text pages and use as foldouts.
 - b. If drawings are too large to be used as foldouts, fold and place drawings in labeled envelopes and bind envelopes in rear of manual. At appropriate locations in manual, insert typewritten pages indicating drawing titles, descriptions of contents, and drawing locations.

2.3 PRODUCT MAINTENANCE MANUALS

- A. Content: Organize manual into a separate section for each product, material, and finish. Include source information, product information, maintenance procedures, repair materials and sources, and warranties and bonds, as described below.

- B. Source Information: List each product included in manual, identified by product name and arranged to match manual's table of contents. For each product, list name, address, and telephone number of installer or supplier and maintenance service agent, and cross-reference Specification Section number and title in Project Manual and drawing or schedule designation or identifier where applicable.
- C. Product Information: Include the following, as applicable:
 - 1. Product name and model number.
 - 2. Manufacturer's name.
 - 3. Color, pattern, and texture.
 - 4. Material and chemical composition.
 - 5. Reordering information for specially manufactured products.
- D. Maintenance Procedures: Include manufacturer's written recommendations and the following:
 - 1. Inspection procedures.
 - 2. Types of cleaning agents to be used and methods of cleaning.
 - 3. List of cleaning agents and methods of cleaning detrimental to product.
 - 4. Schedule for routine cleaning and maintenance.
 - 5. Repair instructions.
- E. Repair Materials and Sources: Include lists of materials and local sources of materials and related services.
- F. Warranties and Bonds: Include copies of warranties and bonds and lists of circumstances and conditions that would affect validity of warranties or bonds.
 - 1. Include procedures to follow and required notifications for warranty claims.

PART 3 - EXECUTION

3.1 MANUAL PREPARATION

- A. Operation and Maintenance Documentation Directory: Prepare a separate manual that provides an organized reference to emergency, operation, and maintenance manuals.
- B. Product Maintenance Manual: Assemble a complete set of maintenance data indicating care and maintenance of each product, material, and finish incorporated into the Work.
- C. Operation and Maintenance Manuals: Assemble a complete set of operation and maintenance data indicating operation and maintenance of each system, subsystem, and piece of equipment not part of a system.
 - 1. Engage a factory-authorized service representative to assemble and prepare information for each system, subsystem, and piece of equipment not part of a system.
 - 2. Prepare a separate manual for each system and subsystem, in the form of an instructional manual for use by Owner's operating personnel.
- D. Manufacturers' Data: Where manuals contain manufacturers' standard printed data, include only sheets pertinent to product or component installed. Mark each sheet to identify each product or component incorporated into the Work. If data include more than one item in a tabular format, identify each item using appropriate references from the Contract Documents. Identify data applicable to the Work and delete references to information not applicable.

1. Prepare supplementary text if manufacturers' standard printed data are not available and where the information is necessary for proper operation and maintenance of equipment or systems.
- E. Drawings: Prepare drawings supplementing manufacturers' printed data to illustrate the relationship of component parts of equipment and systems and to illustrate control sequence and flow diagrams. Coordinate these drawings with information contained in record Drawings to ensure correct illustration of completed installation.
1. Do not use original project record documents as part of operation and maintenance manuals.
 2. Comply with requirements of newly prepared record Drawings in Section 017839 "Project Record Documents."
- F. Comply with Section 017700 "Closeout Procedures" for schedule for submitting operation and maintenance documentation.

END OF SECTION 017823

SECTION 017839 - PROJECT RECORD DOCUMENTS

PART 1 - GENERAL

1.1 RELATED DOCUMENTS

- A. Drawings and general provisions of the Contract, including General and Supplementary Conditions and other Division 01 Specification Sections, apply to this Section.

1.2 SUMMARY

- A. Section includes administrative and procedural requirements for project record documents, including the following:
 - 1. Record Drawings.
 - 2. Record Specifications.
 - 3. Record Product Data.
 - 4. Miscellaneous record submittals.

1.3 CLOSEOUT SUBMITTALS

- A. Record Drawings: Comply with the following:
 - 1. Number of Copies: Submit one set(s) of marked-up record prints.
- B. Record Specifications: Submit one paper copy of Project's Specifications, including addenda and contract modifications.
- C. Record Product Data: Submit one paper copy of each submittal.
 - 1. Where record Product Data are required as part of operation and maintenance manuals, submit duplicate marked-up Product Data as a component of manual.
- D. Miscellaneous Record Submittals: See other Specification Sections for miscellaneous record-keeping requirements and submittals in connection with various construction activities. Submit one paper copy of each submittal.
- E. Reports: Submit written report weekly indicating items incorporated into project record documents concurrent with progress of the Work, including revisions, concealed conditions, field changes, product selections, and other notations incorporated.

PART 2 - PRODUCTS

2.1 RECORD DRAWINGS

- A. Record Prints: Maintain one set of marked-up paper copies of the Contract Drawings and Shop Drawings, incorporating new and revised drawings as modifications are issued.

1. Preparation: Mark record prints to show the actual installation where installation varies from that shown originally. Require individual or entity who obtained record data, whether individual or entity is Installer, subcontractor, or similar entity, to provide information for preparation of corresponding marked-up record prints.
 - a. Give particular attention to information on concealed elements that would be difficult to identify or measure and record later.
 - b. Accurately record information in an acceptable drawing technique.
 - c. Record data as soon as possible after obtaining it.
 - d. Record and check the markup before enclosing concealed installations.
 - e. Cross-reference record prints to corresponding archive photographic documentation.
 2. Content: Types of items requiring marking include, but are not limited to, the following:
 - a. Dimensional changes to Drawings.
 - b. Revisions to details shown on Drawings.
 - c. Depths of foundations below first floor.
 - d. Locations and depths of underground utilities.
 - e. Revisions to routing of piping and conduits.
 - f. Revisions to electrical circuitry.
 - g. Actual equipment locations.
 - h. Changes made by Change Order or Construction Change Directive.
 - i. Changes made following Architect's written orders.
 - j. Details not on the original Contract Drawings.
 - k. Field records for variable and concealed conditions.
 3. Mark the Contract Drawings and Shop Drawings completely and accurately. Use personnel proficient at recording graphic information in production of marked-up record prints.
 4. Mark record sets with erasable, red-colored pencil. Use other colors to distinguish between changes for different categories of the Work at same location.
 5. Mark important additional information that was either shown schematically or omitted from original Drawings.
 6. Note Construction Change Directive numbers, alternate numbers, Change Order numbers, and similar identification, where applicable.
- B. Format: Identify and date each record Drawing; include the designation "PROJECT RECORD DRAWING" in a prominent location.
1. Record Prints: Organize record prints and newly prepared record Drawings into manageable sets. Bind each set with durable paper cover sheets. Include identification on cover sheets.
 2. Record Digital Data Files: Organize digital data information into separate electronic files that correspond to each sheet of the Contract Drawings. Name each file with the sheet identification. Include identification in each digital data file.
 3. Identification: As follows:
 - a. Project name.
 - b. Date.
 - c. Designation "PROJECT RECORD DRAWINGS."
 - d. Name of Architect.
 - e. Name of Contractor.
- 2.2 RECORD SPECIFICATIONS
- A. Preparation: Mark Specifications to indicate the actual product installation where installation varies from that indicated in Specifications, addenda, and contract modifications.

1. Give particular attention to information on concealed products and installations that cannot be readily identified and recorded later.
 2. For each principal product, indicate whether record Product Data has been submitted in operation and maintenance manuals instead of submitted as record Product Data.
 3. Note related Change Orders and record Drawings where applicable.
- B. Format: Submit record Specifications as scanned PDF electronic file(s) of marked-up paper copy of Specifications.

2.3 RECORD PRODUCT DATA

- A. Preparation: Mark Product Data to indicate the actual product installation where installation varies substantially from that indicated in Product Data submittal.
1. Give particular attention to information on concealed products and installations that cannot be readily identified and recorded later.
 2. Include significant changes in the product delivered to Project site and changes in manufacturer's written instructions for installation.
 3. Note related Change Orders, record Specifications, and record Drawings where applicable.
- B. Format: Submit record Product Data as paper copy.
1. Include record Product Data directory organized by Specification Section number and title, electronically linked to each item of record Product Data.

2.4 MISCELLANEOUS RECORD SUBMITTALS

- A. Assemble miscellaneous records required by other Specification Sections for miscellaneous record keeping and submittal in connection with actual performance of the Work. Bind or file miscellaneous records and identify each, ready for continued use and reference.
- B. Format: Submit miscellaneous record submittals as paper copy scanned PDF electronic file(s) of marked-up miscellaneous record submittals.
1. Include miscellaneous record submittals directory organized by Specification Section number and title, electronically linked to each item of miscellaneous record submittals.

PART 3 - EXECUTION

3.1 RECORDING AND MAINTENANCE

- A. Recording: Maintain one copy of each submittal during the construction period for project record document purposes. Post changes and revisions to project record documents as they occur; do not wait until end of Project.
- B. Maintenance of Record Documents and Samples: Store record documents and Samples in the field office apart from the Contract Documents used for construction. Do not use project record documents for construction purposes. Maintain record documents in good order and in a clean, dry, legible condition, protected from deterioration and loss. Provide access to project record documents for Architect's reference during normal working hours.

END OF SECTION 017839

SECTION 024119 - SELECTIVE DEMOLITION

PART 1 - GENERAL

1.1 RELATED DOCUMENTS

- A. Drawings and general provisions of the Contract, including General and Supplementary Conditions and Division 01 Specification Sections, apply to this Section.

1.2 SUMMARY

- A. Section Includes:
 - 1. Demolition and removal of selected portions of building or structure.
 - 2. Demolition and removal of selected site elements.

1.3 DEFINITIONS

- A. Remove: Detach items from existing construction and legally dispose of them off-site unless indicated to be removed and salvaged or removed and reinstalled.
- B. Existing to Remain: Existing items of construction that are not to be permanently removed and that are not otherwise indicated to be removed, removed and salvaged, or removed and reinstalled.

1.4 FIELD CONDITIONS

- A. Conditions existing at time of inspection for bidding purpose will be maintained by Owner as far as practical.
- B. Notify Architect of discrepancies between existing conditions and Drawings before proceeding with selective demolition.
- C. Hazardous Materials: It is not expected that hazardous materials will be encountered in the Work.
- D. Storage or sale of removed items or materials on-site is not permitted.
- E. Utility Service: Maintain existing utilities indicated to remain in service and protect them against damage during selective demolition operations.
 - 1. Maintain fire-protection facilities in service during selective demolition operations.

PART 2 - PRODUCTS

PART 3 - EXECUTION

3.1 EXAMINATION

- A. Verify that utilities have been disconnected and capped before starting selective demolition operations.
- B. Review record documents of existing construction provided by Owner. Owner does not guarantee that existing conditions are same as those indicated in record documents.
- C. Survey existing conditions and correlate with requirements indicated to determine extent of selective demolition required.
- D. When unanticipated mechanical, electrical, or structural elements that conflict with intended function or design are encountered, investigate and measure the nature and extent of conflict. Promptly submit a written report to Architect.

3.2 SELECTIVE DEMOLITION, GENERAL

- A. General: Demolish and remove existing construction only to the extent required by new construction and as indicated. Use methods required to complete the Work within limitations of governing regulations and as follows:
 - 1. Proceed with selective demolition systematically, from higher to lower level. Complete selective demolition operations above each floor or tier before disturbing supporting members on the next lower level.
 - 2. Neatly cut openings and holes plumb, square, and true to dimensions required. Use cutting methods least likely to damage construction to remain or adjoining construction. Use hand tools or small power tools designed for sawing or grinding, not hammering and chopping, to minimize disturbance of adjacent surfaces. Temporarily cover openings to remain.
 - 3. Cut or drill from the exposed or finished side into concealed surfaces to avoid marring existing finished surfaces.
 - 4. Remove decayed, vermin-infested, or otherwise dangerous or unsuitable materials and promptly dispose of off-site.
 - 5. Remove structural framing members and lower to ground by method suitable to avoid free fall and to prevent ground impact or dust generation.
 - 6. Locate selective demolition equipment and remove debris and materials so as not to impose excessive loads on supporting walls, floors, or framing.
 - 7. Dispose of demolished items and materials promptly.

3.3 CLEANING

- A. Clean adjacent structures and improvements of dust, dirt, and debris caused by selective demolition operations. Return adjacent areas to condition existing before selective demolition operations began.

END OF SECTION 024119

SECTION 033000 - CAST-IN-PLACE CONCRETE

PART 1 - GENERAL

1.1 RELATED DOCUMENTS

- A. Drawings and general provisions of the Contract, including General and Supplementary Conditions and Division 01 Specification Sections, apply to this Section.

1.2 DEFINITIONS

- A. Cementitious Materials: Portland cement alone or in combination with one or more of the following: blended hydraulic cement, fly ash and other pozzolans, ground granulated blast-furnace slag, and silica fume; subject to compliance with requirements.

PART 2 - PRODUCTS

2.1 CONCRETE MIXTURES, GENERAL

- A. Prepare design mixtures for each type and strength of concrete, proportioned on the basis of laboratory trial mixture or field test data, or both, according to ACI 301.
 - 1. Use a qualified independent testing agency for preparing and reporting proposed mixture designs based on laboratory trial mixtures.
- B. Limit water-soluble, chloride-ion content in hardened concrete to **[0.06] [0.15] [0.30] [1.00]** percent by weight of cement.

PART 3 - EXECUTION

3.1 FORMWORK

- A. Design, erect, shore, brace, and maintain formwork, according to ACI 301, to support vertical, lateral, static, and dynamic loads, and construction loads that might be applied, until structure can support such loads.
- B. Construct formwork so concrete members and structures are of size, shape, alignment, elevation, and position indicated, within tolerance limits of ACI 117.
- C. Construct forms tight enough to prevent loss of concrete mortar.
- D. Fabricate forms for easy removal without hammering or prying against concrete surfaces. Provide crush or wrecking plates where stripping may damage cast concrete surfaces. Provide top forms for inclined surfaces steeper than 1.5 horizontal to 1 vertical.
 - 1. Install keyways, reglets, recesses, and the like, for easy removal.
 - 2. Do not use rust-stained steel form-facing material.

- E. Set edge forms, bulkheads, and intermediate screed strips for slabs to achieve required elevations and slopes in finished concrete surfaces. Provide and secure units to support screed strips; use strike-off templates or compacting-type screeds.
- F. Provide temporary openings for cleanouts and inspection ports where interior area of formwork is inaccessible. Close openings with panels tightly fitted to forms and securely braced to prevent loss of concrete mortar. Locate temporary openings in forms at inconspicuous locations.
- G. exterior corners and edges of permanently exposed concrete.
- H. Form openings, chases, offsets, sinkages, keyways, reglets, blocking, screeds, and bulkheads required in the Work. Determine sizes and locations from trades providing such items.
- I. Clean forms and adjacent surfaces to receive concrete. Remove chips, wood, sawdust, dirt, and other debris just before placing concrete.
- J. Retighten forms and bracing before placing concrete, as required, to prevent mortar leaks and maintain proper alignment.
- K. Coat contact surfaces of forms with form-release agent, according to manufacturer's written instructions, before placing reinforcement.

3.2 EMBEDDED ITEMS

- A. Place and secure anchorage devices and other embedded items required for adjoining work that is attached to or supported by cast-in-place concrete. Use setting drawings, templates, diagrams, instructions, and directions furnished with items to be embedded.

3.3 REMOVING AND REUSING FORMS

- A. General: Formwork for sides of beams, walls, columns, and similar parts of the Work that does not support weight of concrete may be removed after cumulatively curing at not less than 50 deg F for [24] <Insert number> hours after placing concrete. Concrete has to be hard enough to not be damaged by form-removal operations and curing and protection operations need to be maintained.
 - 1. Leave formwork for beam soffits, joists, slabs, and other structural elements that supports weight of concrete in place until concrete has achieved[**at least 70 percent of**] its 28-day design compressive strength.
 - 2. Remove forms only if shores have been arranged to permit removal of forms without loosening or disturbing shores.
- B. Clean and repair surfaces of forms to be reused in the Work. Split, frayed, delaminated, or otherwise damaged form-facing material will not be acceptable for exposed surfaces. Apply new form-release agent.
- C. When forms are reused, clean surfaces, remove fins and laitance, and tighten to close joints. Align and secure joints to avoid offsets. Do not use patched forms for exposed concrete surfaces unless approved by Architect.

3.4 CONCRETE PLACEMENT

- A. Before placing concrete, verify that installation of formwork, reinforcement, and embedded items is complete and that required inspections have been performed.

- B. Do not add water to concrete during delivery, at Project site, or during placement unless approved by Architect.
- C. Before test sampling and placing concrete, water may be added at Project site, subject to limitations of ACI 301.
- D. Deposit concrete continuously in one layer or in horizontal layers of such thickness that no new concrete will be placed on concrete that has hardened enough to cause seams or planes of weakness. If a section cannot be placed continuously, provide construction joints as indicated. Deposit concrete to avoid segregation.
 - 1. Deposit concrete in horizontal layers of depth to not exceed formwork design pressures and in a manner to avoid inclined construction joints.
 - 2. Consolidate placed concrete with mechanical vibrating equipment according to ACI 301.
 - 3. Do not use vibrators to transport concrete inside forms. Insert and withdraw vibrators vertically at uniformly spaced locations to rapidly penetrate placed layer and at least 6 inches into preceding layer. Do not insert vibrators into lower layers of concrete that have begun to lose plasticity. At each insertion, limit duration of vibration to time necessary to consolidate concrete and complete embedment of reinforcement and other embedded items without causing mixture constituents to segregate.
- E. Cold-Weather Placement: Comply with ACI 306.1 and as follows. Protect concrete work from physical damage or reduced strength that could be caused by frost, freezing actions, or low temperatures.
 - 1. When average high and low temperature is expected to fall below 40 deg F for three successive days, maintain delivered concrete mixture temperature within the temperature range required by ACI 301.
 - 2. Do not use frozen materials or materials containing ice or snow. Do not place concrete on frozen subgrade or on subgrade containing frozen materials.
 - 3. Do not use calcium chloride, salt, or other materials containing antifreeze agents or chemical accelerators unless otherwise specified and approved in mixture designs.
- F. Hot-Weather Placement: Comply with ACI 301 and as follows:
 - 1. Maintain concrete temperature below 90 deg F at time of placement. Chilled mixing water or chopped ice may be used to control temperature, provided water equivalent of ice is calculated to total amount of mixing water. Using liquid nitrogen to cool concrete is Contractor's option.
 - 2. Fog-spray forms, steel reinforcement, and subgrade just before placing concrete. Keep subgrade uniformly moist without standing water, soft spots, or dry areas.

3.5 MISCELLANEOUS CONCRETE ITEMS

- A. Filling In: Fill in holes and openings left in concrete structures after work of other trades is in place unless otherwise indicated. Mix, place, and cure concrete, as specified, to blend with in-place construction. Provide other miscellaneous concrete filling indicated or required to complete the Work.

3.6 CONCRETE SURFACE REPAIRS

- A. Defective Concrete: Repair and patch defective areas when approved by Architect. Remove and replace concrete that cannot be repaired and patched to Architect's approval.
- B. Patching Mortar: Mix dry-pack patching mortar, consisting of one part portland cement to two and one-half parts fine aggregate passing a No. 16 sieve, using only enough water for handling and placing.

- C. Repairing Formed Surfaces: Surface defects include color and texture irregularities, cracks, spalls, air bubbles, honeycombs, rock pockets, fins and other projections on the surface, and stains and other discolorations that cannot be removed by cleaning.
1. Immediately after form removal, cut out honeycombs, rock pockets, and voids more than 1/2 inch in any dimension to solid concrete. Limit cut depth to 3/4 inch. Make edges of cuts perpendicular to concrete surface. Clean, dampen with water, and brush-coat holes and voids with bonding agent. Fill and compact with patching mortar before bonding agent has dried. Fill form-tie voids with patching mortar or cone plugs secured in place with bonding agent.
 2. Repair defects on surfaces exposed to view by blending white portland cement and standard portland cement so that, when dry, patching mortar will match surrounding color. Patch a test area at inconspicuous locations to verify mixture and color match before proceeding with patching. Compact mortar in place and strike off slightly higher than surrounding surface.
 3. Repair defects on concealed formed surfaces that affect concrete's durability and structural performance as determined by Architect.
- D. Repairing Unformed Surfaces: Test unformed surfaces, such as floors and slabs, for finish and verify surface tolerances specified for each surface. Correct low and high areas. Test surfaces sloped to drain for trueness of slope and smoothness; use a sloped template.
1. Repair finished surfaces containing defects. Surface defects include spalls, popouts, honeycombs, rock pockets, crazing and cracks in excess of 0.01 inch wide or that penetrate to reinforcement or completely through unreinforced sections regardless of width, and other objectionable conditions.
 2. After concrete has cured at least 14 days, correct high areas by grinding.
 3. Correct localized low areas during or immediately after completing surface finishing operations by cutting out low areas and replacing with patching mortar. Finish repaired areas to blend into adjacent concrete.
 4. Correct other low areas scheduled to receive floor coverings with a repair underlayment. Prepare, mix, and apply repair underlayment and primer according to manufacturer's written instructions to produce a smooth, uniform, plane, and level surface. Feather edges to match adjacent floor elevations.
 5. Correct other low areas scheduled to remain exposed with a repair topping. Cut out low areas to ensure a minimum repair topping depth of 1/4 inch to match adjacent floor elevations. Prepare, mix, and apply repair topping and primer according to manufacturer's written instructions to produce a smooth, uniform, plane, and level surface.
 6. Repair defective areas, except random cracks and single holes 1 inch or less in diameter, by cutting out and replacing with fresh concrete. Remove defective areas with clean, square cuts and expose steel reinforcement with at least a 3/4-inch clearance all around. Dampen concrete surfaces in contact with patching concrete and apply bonding agent. Mix patching concrete of same materials and mixture as original concrete except without coarse aggregate. Place, compact, and finish to blend with adjacent finished concrete. Cure in same manner as adjacent concrete.
 7. Repair random cracks and single holes 1 inch or less in diameter with patching mortar. Groove top of cracks and cut out holes to sound concrete and clean off dust, dirt, and loose particles. Dampen cleaned concrete surfaces and apply bonding agent. Place patching mortar before bonding agent has dried. Compact patching mortar and finish to match adjacent concrete. Keep patched area continuously moist for at least 72 hours.
- E. Perform structural repairs of concrete, subject to Architect's approval, using epoxy adhesive and patching mortar.
- F. Repair materials and installation not specified above may be used, subject to Architect's approval.

END OF SECTION 033000

SECTION 042000 - UNIT MASONRY

PART 1 - GENERAL

1.1 RELATED DOCUMENTS

- A. Drawings and general provisions of the Contract, including General and Supplementary Conditions and Division 01 Specification Sections, apply to this Section.

1.2 SUMMARY

- A. Section Includes:
 - 1. Concrete masonry units.
 - 2. Mortar and grout.
 - 3. Steel reinforcing bars.
 - 4. Masonry joint reinforcement.
 - 5. Ties and anchors.
 - 6. Miscellaneous masonry accessories.

1.3 DEFINITIONS

- A. CMU(s): Concrete masonry unit(s).
- B. Reinforced Masonry: Masonry containing reinforcing steel in grouted cells.

1.4 PERFORMANCE REQUIREMENTS

- A. Provide structural unit masonry that develops indicated net-area compressive strengths at 28 days.
 - 1. Determine net-area compressive strength of masonry from average net-area compressive strengths of masonry units and mortar types (unit-strength method) according to Tables 1 and 2 in ACI 530.1/ASCE 6/TMS 602.
 - 2. Determine net-area compressive strength of masonry by testing masonry prisms according to ASTM C 1314.

1.5 PRECONSTRUCTION TESTING

- A. Preconstruction Testing Service: Owner will engage a qualified independent testing agency to perform preconstruction testing indicated below. Retesting of materials that fail to comply with specified requirements shall be done at Contractor's expense.
 - 1. Prism Test: For each type of construction required, according to ASTM C 1314.

1.6 ACTION SUBMITTALS

- A. Product Data: For each type of product indicated.

- B. Shop Drawings: For the following:
1. Masonry Units: Show sizes, profiles, coursing, and locations of special shapes.
 2. Cast Stone Trim Units: Show sizes, profiles, and locations of interface with each cast stone trim unit required.
 3. Reinforcing Steel: Detail bending and placement of unit masonry reinforcing bars. Comply with ACI 315, "Details and Detailing of Concrete Reinforcement." Show elevations of reinforced walls.
 4. Fabricated Flashing: Detail corner units, end-dam units, and other special applications.
- C. Samples for Initial Selection:
1. Face brick, in the form of straps of five or more bricks.
 2. Cast stone trim.
 3. Colored mortar.
- D. Samples for Verification: For each type and color of the following:
1. Exposed CMUs.
 2. Face brick, in the form of straps of five or more bricks.
 3. Special brick shapes.
 4. Stone and Cast Stone trim.
 5. Pigmented and colored-aggregate mortar. Make Samples using same sand and mortar ingredients to be used on Project.
 6. Weep holes and vents.
 7. Accessories embedded in masonry.

1.7 INFORMATIONAL SUBMITTALS

- A. Qualification Data: For testing agency.
- B. Material Certificates: For each type and size of the following:
1. Masonry units.
 - a. For brick, include size-variation data verifying that actual range of sizes falls within specified tolerances.
 - b. For masonry units used in structural masonry, include data and calculations establishing average net-area compressive strength of units.
 2. Preblended, dry mortar mixes. Include description of type and proportions of ingredients.
 3. Grout mixes. Include description of type and proportions of ingredients.
 4. Joint reinforcement.
 5. Anchors, ties, and metal accessories.
- C. Statement of Compressive Strength of Masonry: For each combination of masonry unit type and mortar type, provide statement of average net-area compressive strength of masonry units, mortar type, and resulting net-area compressive strength of masonry determined according to Tables 1 and 2 in ACI 530.1/ASCE 6/TMS 602.

1.8 QUALITY ASSURANCE

- A. Testing Agency Qualifications: Qualified according to ASTM C 1093 for testing indicated.
- B. Source Limitations for Masonry Units: Obtain exposed masonry units of a uniform texture and color, or a uniform blend within the ranges accepted for these characteristics, from single source from single manufacturer for each product required.

- C. Source Limitations for Mortar Materials: Obtain mortar ingredients of a uniform quality, including color for exposed masonry, from single manufacturer for each cementitious component and from single source or producer for each aggregate.
- D. Masonry Standard: Comply with ACI 530.1/ASCE 6/TMS 602 unless modified by requirements in the Contract Documents.

1.9 DELIVERY, STORAGE, AND HANDLING

- A. Store masonry units on elevated platforms in a dry location. If units are not stored in an enclosed location, cover tops and sides of stacks with waterproof sheeting, securely tied. If units become wet, do not install until they are dry.
- B. Store cementitious materials on elevated platforms, under cover, and in a dry location. Do not use cementitious materials that have become damp.
- C. Store aggregates where grading and other required characteristics can be maintained and contamination avoided.
- D. Store masonry accessories, including metal items, to prevent corrosion and accumulation of dirt and oil.

1.10 PROJECT CONDITIONS

- A. Protection of Masonry: During construction, cover tops of walls, projections, and sills with waterproof sheeting at end of each day's work. Cover partially completed masonry when construction is not in progress.
 - 1. Extend cover a minimum of 24 inches down both sides of walls and hold cover securely in place.
 - 2. Where one wythe of multiwythe masonry walls is completed in advance of other wythes, secure cover a minimum of 24 inches down face next to unconstructed wythe and hold cover in place.
- B. Do not apply uniform floor or roof loads for at least 12 hours and concentrated loads for at least three days after building masonry walls or columns.
- C. Stain Prevention: Prevent grout, mortar, and soil from staining the face of masonry to be left exposed or painted. Immediately remove grout, mortar, and soil that come in contact with such masonry.
 - 1. Protect base of walls from rain-splashed mud and from mortar splatter by spreading coverings on ground and over wall surface.
 - 2. Protect sills, ledges, and projections from mortar droppings.
 - 3. Protect surfaces of window and door frames, as well as similar products with painted and integral finishes, from mortar droppings.
 - 4. Turn scaffold boards near the wall on edge at the end of each day to prevent rain from splashing mortar and dirt onto completed masonry.
- D. Cold-Weather Requirements: Do not use frozen materials or materials mixed or coated with ice or frost. Do not build on frozen substrates. Remove and replace unit masonry damaged by frost or by freezing conditions. Comply with cold-weather construction requirements contained in ACI 530.1/ASCE 6/TMS 602.
 - 1. Cold-Weather Cleaning: Use liquid cleaning methods only when air temperature is 40 deg F and higher and will remain so until masonry has dried, but not less than seven days after completing cleaning.

- E. Hot-Weather Requirements: Comply with hot-weather construction requirements contained in ACI 530.1/ASCE 6/TMS 602.

PART 2 - PRODUCTS

2.1 MASONRY UNITS, GENERAL

- A. Defective Units: Referenced masonry unit standards may allow a certain percentage of units to contain chips, cracks, or other defects exceeding limits stated in the standard. Do not use units where such defects will be exposed in the completed Work.
- B. Fire-Resistance Ratings: Where indicated, provide units that comply with requirements for fire-resistance ratings indicated as determined by testing according to ASTM E 119, by equivalent masonry thickness, or by other means, as acceptable to authorities having jurisdiction.

2.2 CONCRETE MASONRY UNITS

- A. Shapes: Provide shapes indicated and as follows, with exposed surfaces matching exposed faces of adjacent units unless otherwise indicated.
 - 1. Provide special shapes for lintels, corners, jambs, sashes, movement joints, headers, bonding, and other special conditions.

[This is typically for CMU exterior veneer. Delete if no CMU veneer. \(SSS 8/2010\)](#)

- B. Integral Water Repellent: Provide units made with integral water repellent for exterior exposed units and where indicated.
 - 1. Integral Water Repellent: Liquid polymeric, integral water-repellent admixture that does not reduce flexural bond strength. Units made with integral water repellent, when tested according to ASTM E 514 as a wall assembly made with mortar containing integral water-repellent manufacturer's mortar additive, with test period extended to 24 hours, shall show no visible water or leaks on the back of test specimen.
 - a. Products: Subject to compliance with requirements, provide one of the following:
 - 1) ACM Chemistries; RainBloc.
 - 2) BASF Aktiengesellschaft; Rheopel Plus.
 - 3) Grace Construction Products, W. R. Grace & Co. - Conn.; Dry-Block.
- C. CMUs: ASTM C 90.
 - 1. Density Classification: Lightweight.
 - 2. Size (Width): Manufactured to dimensions 3/8 inch less than nominal dimensions.
 - 3. Exposed Faces: Provide color and texture matching the range represented by Architect's sample.

2.3 MASONRY LINTELS

- A. General: Provide one of the following:
- B. Masonry Lintels: Prefabricated or built-in-place masonry lintels made from bond beam CMUs with reinforcing bars placed as indicated and filled with coarse grout. Cure precast lintels before handling and installing. Temporarily support built-in-place lintels until cured.

C. Face Brick: Facing brick complying with ASTM C 216.

1. Products: Subject to compliance with requirements, provide the following:

2.4 MORTAR AND GROUT MATERIALS

A. Regional Materials: Aggregate for mortar and grout, cement, and lime shall be extracted, harvested, or recovered, as well as manufactured, within 500 miles of Project site.

B. Portland Cement: ASTM C 150, Type I or II, except Type III may be used for cold-weather construction. Provide natural color or white cement as required to produce mortar color indicated.

C. Hydrated Lime: ASTM C 207, Type S.

D. Portland Cement-Lime Mix: Packaged blend of portland cement and hydrated lime containing no other ingredients.

E. Mortar Cement: ASTM C 1329.

F. Colored Cement Product: Packaged blend made from mortar cement and mortar pigments, all complying with specified requirements, and containing no other ingredients.

1. Formulate blend as required to produce color indicated or, if not indicated, as selected from manufacturer's standard colors.
2. Pigments shall not exceed 10 percent of portland cement by weight.
3. Pigments shall not exceed 5 percent of mortar cement by weight.
4. Match existing adjacent building's brick veneer mortar color.

G. Aggregate for Mortar: ASTM C 144.

1. White-Mortar Aggregates: Natural white sand or crushed white stone.
2. Colored-Mortar Aggregates: Natural sand or crushed stone of color necessary to produce required mortar color.

H. Aggregate for Grout: ASTM C 404.

I. Water-Repellent Admixture: Liquid water-repellent mortar admixture intended for use with CMUs containing integral water repellent by same manufacturer.

1. Products: Subject to compliance with requirements, provide one of the following:
 - a. ACM Chemistries; RainBloc for Mortar.
 - b. BASF Aktiengesellschaft; Rheopel Mortar Admixture.
 - c. Grace Construction Products, W. R. Grace & Co. - Conn.; Dry-Block Mortar Admixture.

J. Water: Potable.

2.5 REINFORCEMENT

A. Uncoated Steel Reinforcing Bars: ASTM A 615/A 615M or ASTM A 996/A 996M, Grade 60.

1. Bars that must be welded shall be grade 60.

B. Masonry Joint Reinforcement, General: ASTM A 951/A 951M.

1. Interior Walls: Mill- galvanized, carbon steel.
 2. Exterior Walls: Hot-dip galvanized, carbon steel.
 3. Wire Size for Side Rods: 0.148-inch diameter.
 4. Wire Size for Cross Rods: 0.148-inch diameter.
 5. Provide in lengths of not less than 10 feet, with prefabricated corner and tee units.
- C. Masonry Joint Reinforcement for Single-Wythe Masonry: Either ladder or truss type with single pair of side rods.
- D. Masonry Joint Reinforcement for Multiwythe Masonry:
1. Adjustable (two-piece) type, either ladder or truss design, with one side rod at each face shell of backing wythe and with separate adjustable ties with pintle-and-eye connections having a maximum adjustment of 1-1/4 inches. Size ties to extend at least halfway through facing wythe but with at least 5/8-inch cover on outside face. Ties have hooks or clips to engage a continuous horizontal wire in the facing wythe.
- E. Masonry Joint Reinforcement for Veneers Anchored with Seismic Masonry-Veneer Anchors: Single 0.187-inch- diameter, hot-dip galvanized, carbon -steel continuous wire.

2.6 TIES AND ANCHORS

- A. Materials: Provide ties and anchors specified in this article that are made from materials that comply with the following unless otherwise indicated.
1. Mill-Galvanized, Carbon-Steel Wire: ASTM A 82/A 82M; with ASTM A 641/A 641M, Class 1 coating.
 2. Hot-Dip Galvanized, Carbon-Steel Wire: ASTM A 82/A 82M; with ASTM A 153/A 153M, Class B-2 coating.
 3. Galvanized Steel Sheet: ASTM A 653/A 653M, Commercial Steel, G60 zinc coating.
 4. Steel Sheet, Galvanized after Fabrication: ASTM A 1008/A 1008M, Commercial Steel, with ASTM A 153/A 153M, Class B coating.
 5. Steel Plates, Shapes, and Bars: ASTM A 36/A 36M.
- B. Wire Ties, General: Unless otherwise indicated, size wire ties to extend at least halfway through veneer but with at least 5/8-inch cover on outside face. Outer ends of wires are bent 90 degrees and extend 2 inches parallel to face of veneer.
- C. Individual Wire Ties: Rectangular units with closed ends and not less than 4 inches wide.
1. Z-shaped ties with ends bent 90 degrees to provide hooks not less than 2 inches long may be used for masonry constructed from solid units.
 2. Where wythes do not align or are of different materials, use adjustable ties with pintle-and-eye connections having a maximum adjustment of 1-1/4 inches.
 3. Wire: Fabricate from 3/16-inch- diameter, hot-dip galvanized steel wire.
- D. Adjustable Anchors for Connecting to Structural Steel Framing: Provide anchors that allow vertical or horizontal adjustment but resist tension and compression forces perpendicular to plane of wall.
1. Anchor Section for Welding to Steel Frame: Crimped 1/4-inch- diameter, hot-dip galvanized steel or stainless-steel wire.
 2. Tie Section: Triangular-shaped wire tie, sized to extend within 1 inch of masonry face, made from 0.187-inch- diameter, hot-dip galvanized steel or stainless-steel wire.
- E. Adjustable Anchors for Connecting to Concrete: Provide anchors that allow vertical or horizontal adjustment but resist tension and compression forces perpendicular to plane of wall.

1. Connector Section: Dovetail tabs for inserting into dovetail slots in concrete and attached to tie section; formed from 0.060-inch- thick, steel sheet, galvanized after fabrication.
 2. Tie Section: Triangular-shaped wire tie, sized to extend within 1 inch of masonry face, made from 0.187-inch- diameter, hot-dip galvanized steel or stainless-steel wire.
- F. Partition Top anchors: 0.105-inch- thick metal plate with 3/8-inch- diameter metal rod 6 inches long welded to plate and with closed-end plastic tube fitted over rod that allows rod to move in and out of tube. Fabricate from steel, hot-dip galvanized after fabrication.

H&B bought Dur-o-Wal from Dayton Superior (SSS 8/2010)

Verify with structural engineer that seismic masonry anchors are required. This is a big change. (SSS 8/2010)

2.7 MISCELLANEOUS ANCHORS

- A. Anchor Bolts: Headed or L-shaped steel bolts complying with ASTM A 307, Grade A; with ASTM A 563 hex nuts and, where indicated, flat washers; hot-dip galvanized to comply with ASTM A 153/A 153M, Class C; of dimensions indicated.
- B. Postinstalled Anchors: Torque-controlled expansion anchors or chemical anchors.
 1. Load Capacity: Capable of sustaining, without failure, a load equal to six times the load imposed when installed in unit masonry and four times the load imposed when installed in concrete, as determined by testing according to ASTM E 488, conducted by a qualified independent testing agency.

Select ONE metal if possible. (SSS 8/2010)

- C. Adhesives, Primers, and Seam Tapes for Flashings: Flashing manufacturer's standard products or products recommended by flashing manufacturer for bonding flashing sheets to each other and to substrates.

2.8 MISCELLANEOUS MASONRY ACCESSORIES

- A. Compressible Filler: Premolded filler strips complying with ASTM D 1056, Grade 2A1; compressible up to 35 percent; of width and thickness indicated; formulated from neoprene or urethane.
- B. Preformed Control-Joint Gaskets: Made from styrene-butadiene-rubber compound, complying with ASTM D 2000, Designation M2AA-805 and designed to fit standard sash block and to maintain lateral stability in masonry wall; size and configuration as indicated.
- C. Bond-Breaker Strips: Asphalt-saturated, organic roofing felt complying with ASTM D 226, Type I (No. 15 asphalt felt).
- D. Reinforcing Bar Positioners: Wire units designed to fit into mortar bed joints spanning masonry unit cells and hold reinforcing bars in center of cells. Units are formed from 0.148-inch steel wire, hot-dip galvanized after fabrication. Provide units designed for number of bars indicated.

2.9 MASONRY CLEANERS

- A. Proprietary Acidic Cleaner: Manufacturer's standard-strength cleaner designed for removing mortar/grout stains, efflorescence, and other new construction stains from new masonry without discoloring or damaging masonry surfaces. Use product expressly approved for intended use by cleaner manufacturer and manufacturer of masonry units being cleaned.
1. Manufacturers: Subject to compliance with requirements, [provide products by one of the following] [available manufacturers offering products that may be incorporated into the Work include, but are not limited to, the following]:
 - a. Diedrich Technologies, Inc.
 - b. EaCo Chem, Inc.
 - c. ProSoCo, Inc.

2.10 MORTAR AND GROUT MIXES

- A. General: Do not use admixtures, including pigments, air-entraining agents, accelerators, retarders, water-repellent agents, antifreeze compounds, or other admixtures, unless otherwise indicated.
1. Do not use calcium chloride in mortar or grout.
 2. Use portland cement-lime or mortar cement mortar unless otherwise indicated.
- B. Mortar for Unit Masonry: Comply with ASTM C 270, Property Specification. Provide the following types of mortar for applications stated unless another type is indicated or needed to provide required compressive strength of masonry.
1. For masonry below grade or in contact with earth, use Type S.
 2. For reinforced masonry, use Type S.
 3. For exterior, above-grade, load-bearing and non-load-bearing walls and parapet walls; for interior load-bearing walls; for interior non-load-bearing partitions; and for other applications where another type is not indicated, use Type N.
 4. For interior non-load-bearing partitions, Type O may be used instead of Type N.
- C. Pigmented Mortar: Use colored cement product or select and proportion pigments with other ingredients to produce color required. Do not add pigments to colored cement products.
1. Pigments shall not exceed 10 percent of portland cement by weight.
 2. Pigments shall not exceed 5 percent of mortar cement by weight.
 3. Mix to match Architect's sample.
 4. Application: Use pigmented mortar for exposed mortar joints with the following units:
 - a. Cast stone trim units.
- D. Colored-Aggregate Mortar: Produce required mortar color by using colored aggregates and natural color or white cement as necessary to produce required mortar color.
1. Mix to match Architect's sample.
 2. Application: Use colored aggregate mortar for exposed mortar joints with the following units:
 - a. Face brick.
- E. Grout for Unit Masonry: Comply with ASTM C 476.

1. Use grout of type indicated or, if not otherwise indicated, of type (fine or coarse) that will comply with Table 1.15.1 in ACI 530.1/ASCE 6/TMS 602 for dimensions of grout spaces and pour height.
2. Provide grout with a slump of 8 to 11 inches as measured according to ASTM C 143/C 143M.

PART 3 - EXECUTION

3.1 EXAMINATION

- A. Examine conditions, with Installer present, for compliance with requirements for installation tolerances and other conditions affecting performance of the Work.
 1. For the record, prepare written report, endorsed by Installer, listing conditions detrimental to performance of work.
 2. Verify that foundations are within tolerances specified.
- B. Before installation, examine rough-in and built-in construction for piping systems to verify actual locations of piping connections.
- C. Proceed with installation only after unsatisfactory conditions have been corrected.

3.2 INSTALLATION, GENERAL

- A. Thickness: Build cavity and composite walls and other masonry construction to full thickness shown. Build single-wythe walls to actual widths of masonry units, using units of widths indicated.
- B. Build chases and recesses to accommodate items specified in this and other Sections.
- C. Leave openings for equipment to be installed before completing masonry. After installing equipment, complete masonry to match the construction immediately adjacent to opening.
- D. Use full-size units without cutting if possible. If cutting is required to provide a continuous pattern or to fit adjoining construction, cut units with motor-driven saws; provide clean, sharp, unchipped edges. Allow units to dry before laying unless wetting of units is specified. Install cut units with cut surfaces and, where possible, cut edges concealed.
- E. Select and arrange units for exposed unit masonry to produce a uniform blend of colors and textures.
 1. Mix units from several pallets or cubes as they are placed.
- F. Matching Existing Masonry: Match coursing, bonding, color, and texture of existing masonry.
- G. Wetting of Brick: Wet brick before laying if initial rate of absorption exceeds 30 g/30 sq. in. per minute when tested per ASTM C 67. Allow units to absorb water so they are damp but not wet at time of laying.

3.3 TOLERANCES

- A. Dimensions and Locations of Elements:

1. For dimensions in cross section or elevation do not vary by more than plus 1/2 inch or minus 1/4 inch.
2. For location of elements in plan do not vary from that indicated by more than plus or minus 1/2 inch.
3. For location of elements in elevation do not vary from that indicated by more than plus or minus 1/4 inch in a story height or 1/2 inch total.

B. Lines and Levels:

1. For bed joints and top surfaces of bearing walls do not vary from level by more than 1/4 inch in 10 feet, or 1/2 inch maximum.
2. For conspicuous horizontal lines, such as lintels, sills, parapets, and reveals, do not vary from level by more than 1/8 inch in 10 feet, 1/4 inch in 20 feet, or 1/2 inch maximum.
3. For vertical lines and surfaces do not vary from plumb by more than 1/4 inch in 10 feet, 3/8 inch in 20 feet, or 1/2 inch maximum.
4. For conspicuous vertical lines, such as external corners, door jambs, reveals, and expansion and control joints, do not vary from plumb by more than 1/8 inch in 10 feet, 1/4 inch in 20 feet, or 1/2 inch maximum.
5. For lines and surfaces do not vary from straight by more than 1/4 inch in 10 feet, 3/8 inch in 20 feet, or 1/2 inch maximum.
6. For vertical alignment of exposed head joints, do not vary from plumb by more than 1/4 inch in 10 feet, or 1/2 inch maximum.
7. For faces of adjacent exposed masonry units, do not vary from flush alignment by more than 1/16 inch except due to warpage of masonry units within tolerances specified for warpage of units.

C. Joints:

1. For bed joints, do not vary from thickness indicated by more than plus or minus 1/8 inch, with a maximum thickness limited to 1/2 inch.
2. For exposed bed joints, do not vary from bed-joint thickness of adjacent courses by more than 1/8 inch.
3. For head and collar joints, do not vary from thickness indicated by more than plus 3/8 inch or minus 1/4 inch.
4. For exposed head joints, do not vary from thickness indicated by more than plus or minus 1/8 inch. Do not vary from adjacent bed-joint and head-joint thicknesses by more than 1/8 inch.
5. For exposed bed joints and head joints of stacked bond, do not vary from a straight line by more than 1/16 inch from one masonry unit to the next.

3.4 LAYING MASONRY WALLS

- A. Lay out walls in advance for accurate spacing of surface bond patterns with uniform joint thicknesses and for accurate location of openings, movement-type joints, returns, and offsets. Avoid using less-than-half-size units, particularly at corners, jambs, and, where possible, at other locations.
- B. Bond Pattern for Exposed Masonry: Unless otherwise indicated, lay exposed masonry in one-half running bond; do not use units with less than nominal 4-inch horizontal face dimensions at corners or jambs.
- C. Lay concealed masonry with all units in a wythe in running bond or bonded by lapping not less than 2 inches. Bond and interlock each course of each wythe at corners. Do not use units with less than nominal 4-inch horizontal face dimensions at corners or jambs.
- D. Stopping and Resuming Work: Stop work by racking back units in each course from those in course below; do not tooth. When resuming work, clean masonry surfaces that are to receive mortar, remove loose masonry units and mortar, and wet brick if required before laying fresh masonry.

- E. Built-in Work: As construction progresses, build in items specified in this and other Sections. Fill in solidly with masonry around built-in items.
- F. Fill space between steel frames and masonry solidly with mortar unless otherwise indicated.
- G. Where built-in items are to be embedded in cores of hollow masonry units, place a layer of metal lath, wire mesh, or plastic mesh in the joint below and rod mortar or grout into core.
- H. Fill cores in hollow CMUs with grout 24 inches under bearing plates, beams, lintels, posts, and similar items unless otherwise indicated.
- I. Build non-load-bearing interior partitions full height of story to underside of solid floor or roof structure above unless otherwise indicated.
 - 1. Install compressible filler in joint between top of partition and underside of structure above.
 - 2. At fire-rated partitions, treat joint between top of partition and underside of structure above to comply with Division 07 Section "Fire-Resistive Joint Systems."

3.5 MORTAR BEDDING AND JOINTING

- A. Lay hollow brick and CMUs as follows:
 - 1. With face shells fully bedded in mortar and with head joints of depth equal to bed joints.
 - 2. With webs fully bedded in mortar in all courses of piers, columns, and pilasters.
 - 3. With webs fully bedded in mortar in grouted masonry, including starting course on footings.
 - 4. With entire units, including areas under cells, fully bedded in mortar at starting course on footings where cells are not grouted.
- B. Lay solid masonry units with completely filled bed and head joints; butter ends with sufficient mortar to fill head joints and shove into place. Do not deeply furrow bed joints or slush head joints.
- C. Tool exposed joints slightly concave when thumbprint hard, using a jointer larger than joint thickness unless otherwise indicated.
- D. Cut joints flush for masonry walls to receive plaster or other direct-applied finishes (other than paint) unless otherwise indicated.

3.6 MASONRY JOINT REINFORCEMENT

- A. General: Install entire length of longitudinal side rods in mortar with a minimum cover of 5/8 inch on exterior side of walls, 1/2 inch elsewhere. Lap reinforcement a minimum of 6 inches.
 - 1. Space reinforcement not more than 16 inches o.c.
 - 2. Space reinforcement not more than 8 inches o.c. in foundation walls and parapet walls.
 - 3. Provide reinforcement not more than 8 inches above and below wall openings and extending 12 inches beyond openings in addition to continuous reinforcement.
- B. Interrupt joint reinforcement at control and expansion joints unless otherwise indicated.
- C. Provide continuity at wall intersections by using prefabricated T-shaped units.
- D. Provide continuity at corners by using prefabricated L-shaped units.

3.7 ANCHORING MASONRY TO STRUCTURAL STEEL AND CONCRETE

- A. Anchor masonry to structural steel and concrete where masonry abuts or faces structural steel or concrete to comply with the following:
 - 1. Provide an open space not less than 1 inch wide between masonry and structural steel or concrete unless otherwise indicated. Keep open space free of mortar and other rigid materials.
 - 2. Anchor masonry with anchors embedded in masonry joints and attached to structure.
 - 3. Space anchors as indicated, but not more than 24 inches o.c. vertically and 36 inches o.c. horizontally.
 - 4. At concrete masonry back-up walls, insert masonry veneer anchors into protruding eyes of horizontal joint reinforcement
 - 5. At concrete walls, insert masonry wall ties into dovetail slots cast into concrete for this purpose.

3.8 CONTROL AND EXPANSION JOINTS

- A. General: Install control and expansion joint materials in unit masonry as masonry progresses. Do not allow materials to span control and expansion joints without provision to allow for in-plane wall or partition movement.
- B. Form control joints in concrete masonry as follows:
 - 1. Fit bond-breaker strips into hollow contour in ends of CMUs on one side of control joint. Fill resultant core with grout and rake out joints in exposed faces for application of sealant.
 - 2. Install preformed control-joint gaskets designed to fit standard sash block.
 - 3. Install interlocking units designed for control joints. Install bond-breaker strips at joint. Keep head joints free and clear of mortar or rake out joint for application of sealant.
 - 4. Install temporary foam-plastic filler in head joints and remove filler when unit masonry is complete for application of sealant.
- C. Form expansion joints in brick as follows:
 - 1. Build flanges of factory-fabricated, expansion-joint units into masonry.
 - 2. Build in compressible joint fillers where indicated.
 - 3. Form open joint full depth of brick wythe and of width indicated, but not less than 3/8 inch for installation of sealant and backer rod specified in Division 07 Section "Joint Sealants."
- D. Provide horizontal, pressure-relieving joints by either leaving an air space or inserting a compressible filler of width required for installing sealant and backer rod specified in Division 07 Section "Joint Sealants," but not less than .
 - 1. Locate horizontal, pressure-relieving joints beneath shelf angles supporting masonry.

3.9 LINTELS

- A. Install steel lintels where indicated.
- B. Provide masonry lintels where shown and where openings of more than 12 inches for brick-size units and 24 inches for block-size units are shown without structural steel or other supporting lintels.
- C. Provide minimum bearing of 8 inches at each jamb unless otherwise indicated.

3.10 REINFORCED UNIT MASONRY INSTALLATION

- A. Temporary Formwork and Shores: Construct formwork and shores as needed to support reinforced masonry elements during construction.
 - 1. Construct formwork to provide shape, line, and dimensions of completed masonry as indicated. Make forms sufficiently tight to prevent leakage of mortar and grout. Brace, tie, and support forms to maintain position and shape during construction and curing of reinforced masonry.
 - 2. Do not remove forms and shores until reinforced masonry members have hardened sufficiently to carry their own weight and other loads that may be placed on them during construction.
- B. Placing Reinforcement: Comply with requirements in ACI 530.1/ASCE 6/TMS 602.
- C. Grouting: Do not place grout until entire height of masonry to be grouted has attained enough strength to resist grout pressure.
 - 1. Comply with requirements in ACI 530.1/ASCE 6/TMS 602 for cleanouts and for grout placement, including minimum grout space and maximum pour height.
 - 2. Limit height of vertical grout pours to not more than 60 inches.

3.11 FIELD QUALITY CONTROL

- A. Testing and Inspecting: Owner will engage special inspectors to perform tests and inspections and prepare reports. Allow inspectors access to scaffolding and work areas, as needed to perform tests and inspections. Retesting of materials that fail to comply with specified requirements shall be done at Contractor's expense.
- B. Inspections: Level 1 special inspections according to the "International Building Code."
 - 1. Begin masonry construction only after inspectors have verified proportions of site-prepared mortar.
 - 2. Place grout only after inspectors have verified compliance of grout spaces and of grades, sizes, and locations of reinforcement.
 - 3. Place grout only after inspectors have verified proportions of site-prepared grout.
- C. Testing Prior to Construction: One set of tests.
- D. Testing Frequency: One set of tests for each 5000 sq. ft. of wall area or portion thereof.
- E. Mortar Aggregate Ratio Test (Proportion Specification): For each mix provided, according to ASTM C 780.
- F. Mortar Test (Property Specification): For each mix provided, according to ASTM C 780. Test mortar for mortar air content.
- G. Prism Test: For each type of construction provided, according to ASTM C 1314 at 7 days and at 28 days.

3.12 REPAIRING, POINTING, AND CLEANING

- A. Remove and replace masonry units that are loose, chipped, broken, stained, or otherwise damaged or that do not match adjoining units. Install new units to match adjoining units; install in fresh mortar, pointed to eliminate evidence of replacement.

- B. Pointing: During the tooling of joints, enlarge voids and holes, except weep holes, and completely fill with mortar. Point up joints, including corners, openings, and adjacent construction, to provide a neat, uniform appearance. Prepare joints for sealant application, where indicated.
- C. In-Progress Cleaning: Clean unit masonry as work progresses by dry brushing to remove mortar fins and smears before tooling joints.
- D. Final Cleaning: After mortar is thoroughly set and cured, clean exposed masonry as follows:
 - 1. Remove large mortar particles by hand with wooden paddles and nonmetallic scrape hoes or chisels.
 - 2. Test cleaning methods on sample wall panel; leave one-half of panel uncleaned for comparison purposes. Obtain Architect's approval of sample cleaning before proceeding with cleaning of masonry.
 - 3. Protect adjacent stone and nonmasonry surfaces from contact with cleaner by covering them with liquid strippable masking agent or polyethylene film and waterproof masking tape.
 - 4. Wet wall surfaces with water before applying cleaners; remove cleaners promptly by rinsing surfaces thoroughly with clear water.
 - 5. Clean brick by bucket-and-brush hand-cleaning method described in BIA Technical Notes 20.
 - 6. Clean masonry with a proprietary acidic cleaner applied according to manufacturer's written instructions.
 - 7. Clean concrete masonry by cleaning method indicated in NCMA TEK 8-2A applicable to type of stain on exposed surfaces.
 - 8. Clean stone trim to comply with stone supplier's written instructions.

3.13 MASONRY WASTE DISPOSAL

- A. Salvageable Materials: Unless otherwise indicated, excess masonry materials are Contractor's property. At completion of unit masonry work, remove from Project site.
- B. Waste Disposal as Fill Material: Dispose of clean masonry waste, including excess or soil-contaminated sand, waste mortar, and broken masonry units, by crushing and mixing with fill material as fill is placed.
 - 1. Crush masonry waste to less than 4 inches in each dimension.
 - 2. Mix masonry waste with at least two parts of specified fill material for each part of masonry waste. Fill material is specified in Division 31 Section "Earth Moving."
 - 3. Do not dispose of masonry waste as fill within 18 inches of finished grade.
- C. Excess Masonry Waste: Remove excess clean masonry waste that cannot be used as fill, as described above, and other masonry waste, and legally dispose of off Owner's property.

END OF SECTION 042000

SECTION 051200 - STRUCTURAL STEEL FRAMING

PART 1 - GENERAL

1.1 RELATED DOCUMENTS

- A. Drawings and general provisions of the Contract, including General and Supplementary Conditions and Division 01 Specification Sections, apply to this Section.

1.2 DEFINITIONS

- A. Structural Steel: Elements of structural-steel frame, as classified by AISC 303, "Code of Standard Practice for Steel Buildings and Bridges."
- B. Seismic-Load-Resisting System: Elements of structural-steel frame designated as "SLRS" or along grid lines designated as "SLRS" on Drawings, including columns, beams, and braces and their connections.
- C. Heavy Sections: Rolled and built-up sections as follows:
 - 1. Shapes included in ASTM A 6/A 6M with flanges thicker than 1-1/2 inches.
 - 2. Welded built-up members with plates thicker than 2 inches.
 - 3. Column base plates thicker than 2 inches.
- D. Protected Zone: Structural members or portions of structural members indicated as "Protected Zone" on Drawings. Connections of structural and nonstructural elements to protected zones are limited.
- E. Demand Critical Welds: Those welds, the failure of which would result in significant degradation of the strength and stiffness of the Seismic-Load-Resisting System and which are indicated as "Demand Critical" or "Seismic Critical" on Drawings.

1.3 PERFORMANCE REQUIREMENTS

- A. Connections: Provide details of simple shear connections required by the Contract Documents to be selected or completed by structural-steel fabricator to withstand loads indicated and comply with other information and restrictions indicated.
 - 1. Select and complete connections using schematic details indicated and AISC 360 14th.
 - 2. Use ASD; data are given at service-load level.
- B. Moment Connections: Type FR, fully restrained.
- C. Construction: Combined system of moment frame, braced frame, and shear walls.

1.4 QUALITY ASSURANCE

- A. Comply with applicable provisions of the following specifications and documents:
 - 1. AISC 303.
 - 2. AISC 341 and AISC 341s1.
 - 3. AISC 360.

4. RCSC's "Specification for Structural Joints Using ASTM A 325 or A 490 Bolts."

1.5 DELIVERY, STORAGE, AND HANDLING

- A. Store materials to permit easy access for inspection and identification. Keep steel members off ground and spaced by using pallets, dunnage, or other supports and spacers. Protect steel members and packaged materials from corrosion and deterioration.
 1. Do not store materials on structure in a manner that might cause distortion, damage, or overload to members or supporting structures. Repair or replace damaged materials or structures as directed.
- B. Store fasteners in a protected place in sealed containers with manufacturer's labels intact.
 1. Fasteners may be repackaged provided Owner's testing and inspecting agency observes repackaging and seals containers.
 2. Clean and relubricate bolts and nuts that become dry or rusty before use.
 3. Comply with manufacturers' written recommendations for cleaning and lubricating ASTM F 1852 fasteners and for retesting fasteners after lubrication.

1.6 COORDINATION

- A. Coordinate selection of shop primers with topcoats to be applied over them. Comply with paint and coating manufacturers' recommendations to ensure that shop primers and topcoats are compatible with one another.
- B. Coordinate installation of anchorage items to be embedded in or attached to other construction without delaying the Work. Provide setting diagrams, sheet metal templates, instructions, and directions for installation.

PART 2 - PRODUCTS

2.1 FABRICATION

- A. Thermal Cutting: Perform thermal cutting by machine to greatest extent possible.
 1. Plane thermally cut edges to be welded to comply with requirements in AWS D1.1/D1.1M.
- B. Bolt Holes: Cut, drill, or punch standard bolt holes perpendicular to metal surfaces.
- C. Finishing: Accurately finish ends of columns and other members transmitting bearing loads.
- D. Holes: Provide holes required for securing other work to structural steel and for other work to pass through steel framing members.
 1. Cut, drill, or punch holes perpendicular to steel surfaces. Do not thermally cut bolt holes or enlarge holes by burning.
 2. Baseplate Holes: Cut, drill, mechanically thermal cut, or punch holes perpendicular to steel surfaces.
 3. Weld threaded nuts to framing and other specialty items indicated to receive other work.

PART 3 - EXECUTION

3.1 EXAMINATION

- A. Verify, with steel Erector present, elevations of concrete- and masonry-bearing surfaces and locations of anchor rods, bearing plates, and other embedments for compliance with requirements.
 - 1. Prepare a certified survey of bearing surfaces, anchor rods, bearing plates, and other embedments showing dimensions, locations, angles, and elevations.
- B. Proceed with installation only after unsatisfactory conditions have been corrected.

3.2 PREPARATION

- A. Provide temporary shores, guys, braces, and other supports during erection to keep structural steel secure, plumb, and in alignment against temporary construction loads and loads equal in intensity to design loads. Remove temporary supports when permanent structural steel, connections, and bracing are in place unless otherwise indicated.
 - 1. Do not remove temporary shoring supporting composite deck construction until cast-in-place concrete has attained its design compressive strength.

3.3 REPAIRS AND PROTECTION

- A. Galvanized Surfaces: Clean areas where galvanizing is damaged or missing and repair galvanizing to comply with ASTM A 780.

END OF SECTION 051200

SECTION 052100 - STEEL JOIST FRAMING

PART 1 - GENERAL

1.1 RELATED DOCUMENTS

- A. Drawings and general provisions of the Contract, including General and Supplementary Conditions and Division 01 Specification Sections, apply to this Section.

1.2 DEFINITIONS

- A. SJI's "Specifications": Steel Joist Institute's "Standard Specifications, Load Tables and Weight Tables for Steel Joists and Joist Girders."
- B. Special Joists: Steel joists or joist girders requiring modification by manufacturer to support nonuniform, unequal, or special loading conditions that invalidate load tables in SJI's "Specifications."

1.3 QUALITY ASSURANCE

- A. Welding Qualifications: Qualify field-welding procedures and personnel according to AWS D1.1/D1.1M, "Structural Welding Code - Steel."

1.4 DELIVERY, STORAGE, AND HANDLING

- A. Deliver, store, and handle joists as recommended in SJI's "Specifications" and "Standard Specifications for Composite Steel Joists, CJ-Series" in "Standard Specifications for Composite Steel Joists, Weight Tables and Bridging Tables, Code of Standard Practice."
- B. Protect joists from corrosion, deformation, and other damage during delivery, storage, and handling.

PART 2 - PRODUCTS

PART 3 - EXECUTION

3.1 EXAMINATION

- A. Examine supporting substrates, embedded bearing plates, and abutting structural framing for compliance with requirements for installation tolerances and other conditions affecting performance.
- B. Proceed with installation only after unsatisfactory conditions have been corrected.

3.2 INSTALLATION

- A. Do not install joists until supporting construction is in place and secured.

- B. Install joists and accessories plumb, square, and true to line; securely fasten to supporting construction according to SJI's "Specifications" and "Standard Specifications for Composite Steel Joists, CJ-Series" in "Standard Specifications for Composite Steel Joists, Weight Tables and Bridging Tables, Code of Standard Practice," joist manufacturer's written recommendations, and requirements in this Section.
 - 1. Before installation, splice joists delivered to Project site in more than one piece.
 - 2. Space, adjust, and align joists accurately in location before permanently fastening.
 - 3. Install temporary bracing and erection bridging, connections, and anchors to ensure that joists are stabilized during construction.
 - 4. Delay rigidly connecting bottom-chord extensions to columns or supports until dead loads are applied.

- C. Install and connect bridging concurrently with joist erection, before construction loads are applied. Anchor ends of bridging lines at top and bottom chords if terminating at walls or beams.

3.3 PROTECTION

- A. Provide final protection and maintain conditions, in a manner acceptable to manufacturer and Installer, that ensure that joists and accessories are without damage or deterioration at time of Substantial Completion.

END OF SECTION 052100

SECTION 053100 - STEEL DECKING

PART 1 - GENERAL

1.1 RELATED DOCUMENTS

- A. Drawings and general provisions of the Contract, including General and Supplementary Conditions and Division 01 Specification Sections, apply to this Section.

1.2 QUALITY ASSURANCE

- A. Welding Qualifications: Qualify procedures and personnel according to AWS D1.3, "Structural Welding Code - Sheet Steel."
- B. FM Global Listing: Provide steel roof deck evaluated by FM Global and listed in its "Approval Guide, Building Materials" for Class 1 fire rating and Class 1-90 windstorm ratings.

1.3 DELIVERY, STORAGE, AND HANDLING

- A. Protect steel deck from corrosion, deformation, and other damage during delivery, storage, and handling.
- B. Stack steel deck on platforms or pallets and slope to provide drainage. Protect with a waterproof covering and ventilate to avoid condensation.

PART 2 - PRODUCTS

PART 3 - EXECUTION

3.1 EXAMINATION

- A. Examine supporting frame and field conditions for compliance with requirements for installation tolerances and other conditions affecting performance.
- B. Proceed with installation only after unsatisfactory conditions have been corrected.

3.2 INSTALLATION, GENERAL

- A. Install deck panels and accessories according to applicable specifications and commentary in SDI Publication No. 31, manufacturer's written instructions, and requirements in this Section.
- B. Install temporary shoring before placing deck panels if required to meet deflection limitations.
- C. Locate deck bundles to prevent overloading of supporting members.
- D. Place deck panels flat and square and fasten to supporting frame without warp or deflection.

- E. Cut and neatly fit deck panels and accessories around openings and other work projecting through or adjacent to deck.
- F. Provide additional reinforcement and closure pieces at openings as required for strength, continuity of deck, and support of other work.
- G. Comply with AWS requirements and procedures for manual shielded metal arc welding, appearance and quality of welds, and methods used for correcting welding work.

3.3 PROTECTION

- A. Provide final protection and maintain conditions to ensure that steel deck is without damage or deterioration at time of Substantial Completion.

END OF SECTION 053100

SECTION 055000 - METAL FABRICATIONS

PART 1 - GENERAL

1.1 RELATED DOCUMENTS

- A. Drawings and general provisions of the Contract, including General and Supplementary Conditions and Division 01 Specification Sections, apply to this Section.

1.2 QUALITY ASSURANCE

- A. Welding Qualifications: Qualify procedures and personnel according to AWS D1.1/D1.1M, "Structural Welding Code - Steel."
- B. Welding Qualifications: Qualify procedures and personnel according to the following:
 - 1. AWS D1.1/D1.1M, "Structural Welding Code - Steel."

1.3 PROJECT CONDITIONS

- A. Field Measurements: Verify actual locations of walls and other construction contiguous with metal fabrications by field measurements before fabrication.

1.4 COORDINATION

- A. Coordinate selection of shop primers with topcoats to be applied over them. Comply with paint and coating manufacturers' written recommendations to ensure that shop primers and topcoats are compatible with one another.

PART 2 - PRODUCTS

2.1 METALS, GENERAL

- A. Metal Surfaces, General: Provide materials with smooth, flat surfaces unless otherwise indicated. For metal fabrications exposed to view in the completed Work, provide materials without seam marks, roller marks, rolled trade names, or blemishes.

2.2 FERROUS METALS

- A. Steel Plates, Shapes, and Bars: ASTM A 36/A 36M.

2.3 NONFERROUS METALS

- A. Bronze Plate, Sheet, Strip, and Bars: ASTM B 36/B 36M, Alloy UNS No. C28000 (muntz metal, 60 percent copper).

2.4 FASTENERS

- A. General: Unless otherwise indicated, provide Type 304 stainless-steel fasteners for exterior use and zinc-plated fasteners with coating complying with ASTM B 633 or ASTM F 1941, Class Fe/Zn 5, at exterior walls. Select fasteners for type, grade, and class required.
- B. Steel Bolts and Nuts: Regular hexagon-head bolts, ASTM A 307, Grade A; with hex nuts, ASTM A 563; and, where indicated, flat washers.
- C. Steel Bolts and Nuts: Regular hexagon-head bolts, ASTM A 325, Type 3; with hex nuts, ASTM A 563, Grade C3; and, where indicated, flat washers.
- D. Stainless-Steel Bolts and Nuts: Regular hexagon-head annealed stainless-steel bolts, ASTM F 593; with hex nuts, ASTM F 594; and, where indicated, flat washers; Alloy Group 1.
- E. Eyebolts: ASTM A 489.
- F. Machine Screws: ASME B18.6.3.
- G. Lag Screws: ASME B18.2.1.
- H. Wood Screws: Flat head, ASME B18.6.1.
- I. Plain Washers: Round, ASME B18.22.1.
- J. Lock Washers: Helical, spring type, ASME B18.21.1.

2.5 MISCELLANEOUS MATERIALS

- A. Welding Rods and Bare Electrodes: Select according to AWS specifications for metal alloy welded.
- B. Shop Primers: Provide primers that comply with
- C. Bituminous Paint: Cold-applied asphalt emulsion complying with ASTM D 1187.

2.6 FABRICATION, GENERAL

- A. Shop Assembly: Preassemble items in the shop to greatest extent possible. Disassemble units only as necessary for shipping and handling limitations. Use connections that maintain structural value of joined pieces. Clearly mark units for reassembly and coordinated installation.
- B. Cut, drill, and punch metals cleanly and accurately. Remove burrs and ease edges to a radius of approximately 1/32 inch unless otherwise indicated. Remove sharp or rough areas on exposed surfaces.
- C. Form bent-metal corners to smallest radius possible without causing grain separation or otherwise impairing work.
- D. Form exposed work with accurate angles and surfaces and straight edges.
- E. Weld corners and seams continuously to comply with the following:
 - 1. Use materials and methods that minimize distortion and develop strength and corrosion resistance of base metals.
 - 2. Obtain fusion without undercut or overlap.

3. Remove welding flux immediately.
 4. At exposed connections, finish exposed welds and surfaces smooth and blended so no roughness shows after finishing.
- F. Form exposed connections with hairline joints, flush and smooth, using concealed fasteners or welds where possible. Where exposed fasteners are required, use Phillips flat-head (countersunk) fasteners unless otherwise indicated. Locate joints where least conspicuous.
- G. Fabricate seams and other connections that will be exposed to weather in a manner to exclude water. Provide weep holes where water may accumulate.
- H. Cut, reinforce, drill, and tap metal fabrications as indicated to receive finish hardware, screws, and similar items.
- I. Provide for anchorage of type indicated; coordinate with supporting structure. Space anchoring devices to secure metal fabrications rigidly in place and to support indicated loads.
1. Where units are indicated to be cast into concrete or built into masonry, equip with integrally welded steel strap anchors, 1/8 by 1-1/2 inches, with a minimum 6-inch embedment and 2-inch hook, not less than 8 inches from ends and corners of units and 24 inches o.c., unless otherwise indicated.

2.7 MISCELLANEOUS FRAMING AND SUPPORTS

- A. General: Provide steel framing and supports not specified in other Sections as needed to complete the Work.
- B. Fabricate units from steel shapes, plates, and bars of welded construction unless otherwise indicated. Fabricate to sizes, shapes, and profiles indicated and as necessary to receive adjacent construction.
- C. Prime miscellaneous framing and supports with where indicated.

2.8 FINISHES, GENERAL

- A. Comply with NAAMM's "Metal Finishes Manual for Architectural and Metal Products" for recommendations for applying and designating finishes.
- B. Finish metal fabrications after assembly.
- C. Finish exposed surfaces to remove tool and die marks and stretch lines, and to blend into surrounding surface.

2.9 STEEL AND IRON FINISHES

- A. Shop prime iron and steel items not indicated to be galvanized unless they are to be embedded in concrete, sprayed-on fireproofing, or masonry, or unless otherwise indicated.
1. Shop prime with unless indicated.

PART 3 - EXECUTION

3.1 INSTALLATION, GENERAL

- A. Cutting, Fitting, and Placement: Perform cutting, drilling, and fitting required for installing metal fabrications. Set metal fabrications accurately in location, alignment, and elevation; with edges and surfaces level, plumb, true, and free of rack; and measured from established lines and levels.
- B. Fit exposed connections accurately together to form hairline joints. Weld connections that are not to be left as exposed joints but cannot be shop welded because of shipping size limitations. Do not weld, cut, or abrade surfaces of exterior units that have been hot-dip galvanized after fabrication and are for bolted or screwed field connections.
- C. Field Welding: Comply with the following requirements:
 - 1. Use materials and methods that minimize distortion and develop strength and corrosion resistance of base metals.
 - 2. Obtain fusion without undercut or overlap.
 - 3. Remove welding flux immediately.
 - 4. At exposed connections, finish exposed welds and surfaces smooth and blended so no roughness shows after finishing and contour of welded surface matches that of adjacent surface.
- D. Fastening to In-Place Construction: Provide anchorage devices and fasteners where metal fabrications are required to be fastened to in-place construction. Provide threaded fasteners for use with concrete and masonry inserts, toggle bolts, through bolts, lag screws, wood screws, and other connectors.
- E. Provide temporary bracing or anchors in formwork for items that are to be built into concrete, masonry, or similar construction.

END OF SECTION 055000

SECTION 061053 - MISCELLANEOUS ROUGH CARPENTRY

PART 1 - GENERAL

1.1 RELATED DOCUMENTS

- A. Drawings and general provisions of the Contract, including General and Supplementary Conditions and Division 01 Specification Sections, apply to this Section.

1.2 SUMMARY

- A. Section Includes:
 - 1. Wood blocking, cants, and nailers.
 - 2. Wood furring and grounds.
 - 3. Wood sleepers.
 - 4. Plywood backing panels.

1.3 DEFINITIONS

- A. Dimension Lumber: Lumber of 2 inches nominal or greater but less than 5 inches nominal in least dimension.
- B. Lumber grading agencies, and the abbreviations used to reference them, include the following:
 - 1. NeLMA: Northeastern Lumber Manufacturers' Association.
 - 2. NLGA: National Lumber Grades Authority.
 - 3. SPIB: The Southern Pine Inspection Bureau.

1.4 ACTION SUBMITTALS

- A. Product Data: For each type of process and factory-fabricated product. Indicate component materials and dimensions and include construction and application details.
 - 1. Include data for wood-preservative treatment from chemical treatment manufacturer and certification by treating plant that treated materials comply with requirements. Indicate type of preservative used and net amount of preservative retained.
 - 2. For products receiving a waterborne treatment, include statement that moisture content of treated materials was reduced to levels specified before shipment to Project site.
 - 3. Include copies of warranties from chemical treatment manufacturers for each type of treatment.

1.5 INFORMATIONAL SUBMITTALS

- A. Evaluation Reports: For the following, from ICC-ES:
 - 1. Preservative-treated wood.
 - 2. Power-driven fasteners.
 - 3. Powder-actuated fasteners.
 - 4. Expansion anchors.

1.6 DELIVERY, STORAGE, AND HANDLING

- A. Stack lumber flat with spacers beneath and between each bundle to provide air circulation. Protect lumber from weather by covering with waterproof sheeting, securely anchored. Provide for air circulation around stacks and under coverings.

PART 2 - PRODUCTS

2.1 WOOD PRODUCTS, GENERAL

- A. Lumber: DOC PS 20 and applicable rules of grading agencies indicated. If no grading agency is indicated, provide lumber that complies with the applicable rules of any rules-writing agency certified by the ALSC Board of Review. Provide lumber graded by an agency certified by the ALSC Board of Review to inspect and grade lumber under the rules indicated.
 - 1. Factory mark each piece of lumber with grade stamp of grading agency.
 - 2. Where nominal sizes are indicated, provide actual sizes required by DOC PS 20 for moisture content specified. Where actual sizes are indicated, they are minimum dressed sizes for dry lumber.
 - 3. Provide dressed lumber, S4S, unless otherwise indicated.
- B. Maximum Moisture Content of Lumber: (19 percent for 2-inch nominal (38-mm actual) thickness or less, no limit for more than 2-inch nominal (38-mm actual) thickness unless otherwise indicated.

2.2 WOOD-PRESERVATIVE-TREATED MATERIALS

- A. Preservative Treatment by Pressure Process: AWPA U1; Use Category UC2 for interior construction not in contact with the ground, Use Category UC3b for exterior construction not in contact with the ground, and Use Category UC4a for items in contact with the ground.
 - 1. Preservative Chemicals: Acceptable to authorities having jurisdiction and containing no arsenic or chromium. Do not use inorganic boron (SBX) for sill plates.
- B. Kiln-dry lumber after treatment to a maximum moisture content of 19 percent. Do not use material that is warped or does not comply with requirements for untreated material.
- C. Mark lumber with treatment quality mark of an inspection agency approved by the ALSC Board of Review.
- D. Application: Treat items indicated on Drawings, and the following:
 - 1. Wood cants, nailers, curbs, equipment support bases, blocking, stripping, and similar members in connection with roofing, flashing, vapor barriers, and waterproofing.
 - 2. Wood sills, sleepers, blocking, furring, stripping, and similar concealed members in contact with masonry or concrete.
 - 3. Wood framing and furring attached directly to the interior of below-grade exterior masonry or concrete walls.

2.3 MISCELLANEOUS LUMBER

- A. General: Provide miscellaneous lumber indicated and lumber for support or attachment of other construction, including the following:

1. Blocking.
2. Nailers.
3. Cants.
4. Furring.
5. Grounds.

B. For items of dimension lumber size, provide Construction or No. 2 grade lumber of any species.

1. Hem-fir (north); NLGA.
2. Mixed southern pine; SPIB.
3. Spruce-pine-fir; NLGA.
4. Spruce-pine-fir (south); NeLMA, WCLIB, or WWPA.

C. For blocking not used for attachment of other construction, Utility, Stud, or No. 3 grade lumber of any species may be used provided that it is cut and selected to eliminate defects that will interfere with its attachment and purpose.

D. For blocking and nailers used for attachment of other construction, select and cut lumber to eliminate knots and other defects that will interfere with attachment of other work.

E. For furring strips for installing plywood or hardboard paneling, select boards with no knots capable of producing bent-over nails and damage to paneling.

2.4 PLYWOOD BACKING PANELS

A. Equipment Backing Panels: DOC PS 1, Exposure 1, C-D Plugged, in thickness indicated or, if not indicated, not less than 1/2-inch nominal thickness.

2.5 FASTENERS

A. General: Provide fasteners of size and type indicated that comply with requirements specified in this article for material and manufacture.

1. Where carpentry is exposed to weather, in ground contact, pressure-preservative treated, or in area of high relative humidity, provide fasteners with hot-dip zinc coating complying with ASTM A 153/A 153M.

B. Power-Driven Fasteners: NES NER-272.

C. Wood Screws: ASME B18.6.1.

D. Screws for Fastening to Metal Framing: ASTM C 954, length as recommended by screw manufacturer for material being fastened.

E. Lag Bolts: ASME B18.2.1.

F. Bolts: Steel bolts complying with ASTM A 307, Grade A; with ASTM A 563 hex nuts and, where indicated, flat washers.

G. Expansion Anchors: Anchor bolt and sleeve assembly of material indicated below with capability to sustain, without failure, a load equal to 6 times the load imposed when installed in unit masonry assemblies and equal to 4 times the load imposed when installed in concrete as determined by testing per ASTM E 488 conducted by a qualified independent testing and inspecting agency.

1. Material: Carbon-steel components, zinc plated to comply with ASTM B 633, Class Fe/Zn 5.

2.6 METAL FRAMING ANCHORS

- A. Galvanized-Steel Sheet: Hot-dip, zinc-coated steel sheet complying with ASTM A 653/A 653M, G60 coating designation.
 1. Use for interior locations unless otherwise indicated.
- B. Hot-Dip Heavy-Galvanized Steel Sheet: ASTM A 653/A 653M; Structural Steel (SS), high-strength low-alloy steel Type A (HSLAS Type A), or high-strength low-alloy steel Type B (HSLAS Type B); G185 coating designation; and not less than 0.036 inch thick.
 1. Use for wood-preservative-treated lumber and where indicated.

PART 3 - EXECUTION

3.1 INSTALLATION, GENERAL

- A. Set carpentry to required levels and lines, with members plumb, true to line, cut, and fitted. Fit carpentry to other construction; scribe and cope as needed for accurate fit. Locate furring, nailers, blocking, grounds, and similar supports to comply with requirements for attaching other construction.
- B. Where wood-preservative-treated lumber is installed adjacent to metal decking, install continuous flexible flashing separator between wood and metal decking.
- C. Install plywood backing panels by fastening through gypsum wallboard to studs; coordinate locations with utilities requiring backing panels.
- D. Metal Framing Anchors: Install metal framing anchors to comply with manufacturer's written instructions. Install fasteners through each fastener hole.
- E. Do not splice structural members between supports unless otherwise indicated.
- F. Provide blocking and framing as indicated and as required to support facing materials, fixtures, specialty items, and trim.
 1. Provide metal clips for fastening gypsum board or lath at corners and intersections where framing or blocking does not provide a surface for fastening edges of panels. Space clips not more than 16 inches o.c.
- G. Provide fire blocking in furred spaces, stud spaces, and other concealed cavities as indicated and as follows:
 1. Fire block furred spaces of walls, at each floor level, at ceiling, and at not more than 96 inches o.c. with solid wood blocking or noncombustible materials accurately fitted to close furred spaces.
- H. Sort and select lumber so that natural characteristics will not interfere with installation or with fastening other materials to lumber. Do not use materials with defects that interfere with function of member or pieces that are too small to use with minimum number of joints or optimum joint arrangement.

- I. Comply with AWPA M4 for applying field treatment to cut surfaces of preservative-treated lumber.
 - 1. Use inorganic boron for items that are continuously protected from liquid water.
 - 2. Use copper naphthenate for items not continuously protected from liquid water.

- J. Securely attach carpentry work to substrate by anchoring and fastening as indicated, complying with the following:
 - 1. NES NER-272 for power-driven fasteners.
 - 2. Table 2304.9.1, "Fastening Schedule," in ICC's International Building Code.

- K. Use steel common nails unless otherwise indicated. Select fasteners of size that will not fully penetrate members where opposite side will be exposed to view or will receive finish materials. Make tight connections between members. Install fasteners without splitting wood. Drive nails snug but do not countersink nail heads unless otherwise indicated.

3.2 WOOD GROUND, SLEEPER, BLOCKING, AND NAILER INSTALLATION

- A. Install where indicated and where required for attaching other work. Form to shapes indicated and cut as required for true line and level of attached work. Coordinate locations with other work involved.

- B. Attach items to substrates to support applied loading. Recess bolts and nuts flush with surfaces unless otherwise indicated.

3.3 WOOD FURRING INSTALLATION

- A. Install level and plumb with closure strips at edges and openings. Shim with wood as required for tolerance of finish work.

3.4 PROTECTION

- A. Protect wood that has been treated with inorganic boron (SBX) from weather. If, despite protection, inorganic boron-treated wood becomes wet, apply EPA-registered borate treatment. Apply borate solution by spraying to comply with EPA-registered label.

END OF SECTION 061053

SECTION 064116 - PLASTIC-LAMINATE-FACED ARCHITECTURAL CABINETS

PART 1 - GENERAL

1.1 RELATED DOCUMENTS

- A. Drawings and general provisions of the Contract, including General and Supplementary Conditions and Division 01 Specification Sections, apply to this Section.

1.2 SUMMARY

- A. Section Includes:
 - 1. Plastic-laminate-faced architectural cabinets.
 - 2. Wood furring, blocking, shims, and hanging strips for installing plastic-laminate-faced architectural cabinets unless concealed within other construction before cabinet installation.

1.3 ACTION SUBMITTALS

- A. Product Data: For each type of product, including panel products high-pressure decorative laminate and cabinet hardware and accessories.
- B. Shop Drawings: Show location of each item, dimensioned plans and elevations, large-scale details, attachment devices, and other components.
 - 1. Show details full size.
 - 2. Show locations and sizes of furring, blocking, and hanging strips, including concealed blocking and reinforcement specified in other Sections.
 - 3. Apply AWI Quality Certification Program label to Shop Drawings.
- C. Samples for Initial Selection:
 - 1. Plastic laminates.
 - 2. PVC edge material.

1.4 QUALITY ASSURANCE

- A. Fabricator Qualifications: Shop that employs skilled workers who custom fabricate products similar to those required for this Project and whose products have a record of successful in-service performance. Shop is a certified participant in AWI's Quality Certification Program.
- B. Installer Qualifications: Certified participant in AWI's Quality Certification Program.
- C. Testing Agency Qualifications: For testing agency providing classification marking for fire-retardant-treated material, an inspection agency acceptable to authorities having jurisdiction that periodically performs inspections to verify that the material bearing the classification marking is representative of the material tested.

1.5 DELIVERY, STORAGE, AND HANDLING

- A. Do not deliver cabinets until painting and similar operations that could damage woodwork have been completed in installation areas. If cabinets must be stored in other than installation areas, store only in areas where environmental conditions comply with requirements specified in "Field Conditions" Article.

1.6 FIELD CONDITIONS

- A. Environmental Limitations: Do not deliver or install cabinets until building is enclosed, wet work is complete, and HVAC system is operating and maintaining temperature and relative humidity at occupancy levels during the remainder of the construction period.
- B. Environmental Limitations: Do not deliver or install cabinets until building is enclosed, wet work is complete, and HVAC system is operating and maintaining temperature between 60 and 90 deg F and relative humidity between 25 and 55 percent during the remainder of the construction period.
- C. Field Measurements: Where cabinets are indicated to fit to other construction, verify dimensions of other construction by field measurements before fabrication, and indicate measurements on Shop Drawings. Coordinate fabrication schedule with construction progress to avoid delaying the Work.
 - 1. Locate concealed framing, blocking, and reinforcements that support cabinets by field measurements before being enclosed, and indicate measurements on Shop Drawings.
- D. Established Dimensions: Where cabinets are indicated to fit to other construction, establish dimensions for areas where cabinets are to fit. Provide allowance for trimming at site, and coordinate construction to ensure that actual dimensions correspond to established dimensions.

1.7 COORDINATION

- A. Coordinate sizes and locations of framing, blocking, furring, reinforcements, and other related units of Work specified in other Sections to ensure that cabinets can be supported and installed as indicated.

PART 2 - PRODUCTS

2.1 PLASTIC-LAMINATE-FACED ARCHITECTURAL CABINETS

- A. Quality Standard: Unless otherwise indicated, comply with the "Architectural Woodwork Standards" for grades of architectural plastic-laminate cabinets indicated for construction, finishes, installation, and other requirements.
 - 1. Provide labels and certificates from certification program indicating that woodwork, including installation, complies with requirements of grades specified.
 - 2. The Contract Documents contain selections chosen from options in the quality standard and additional requirements beyond those of the quality standard. Comply with those selections and requirements in addition to the quality standard.
- B. Grade: Premium.
- C. Regional Materials: Plastic-laminate cabinets shall be manufactured within 500 miles of Project site.

- D. Type of Construction: Frameless.
- E. Cabinet, Door, and Drawer Front Interface Style: Flush overlay.
- F. Reveal Dimension: 1/2 inch.
- G. High-Pressure Decorative Laminate: NEMA LD 3, grades as indicated or if not indicated, as required by woodwork quality standard.
 - 1. Manufacturers: Subject to compliance with requirements, available manufacturers offering products that may be incorporated into the Work include, but are not limited to, the following:
 - a. Formica Corporation.
 - b. Panolam Industries International, Inc.
 - c. Wilsonart International; Div. of Premark International, Inc.
- H. Laminate Cladding for Exposed Surfaces:
 - 1. Horizontal Surfaces: Grade HGS.
 - 2. Postformed Surfaces: Grade HGP.
 - 3. Vertical Surfaces: Grade VGS.
 - 4. Edges: PVC edge banding, 0.12 inch thick, matching laminate in color, pattern, and finish.
 - 5. Pattern Direction: Vertically for drawer fronts, doors, and fixed panels.
- I. Materials for Semiexposed Surfaces:
 - 1. Surfaces Other Than Drawer Bodies: High-pressure decorative laminate, NEMA LD 3, Grade VGS.
 - a. Edges of Plastic-Laminate Shelves: PVC edge banding, 0.12 inch thick, matching laminate in color, pattern, and finish.
 - b. Edges of Thermoset Decorative Panel Shelves: PVC or polyester edge banding.
 - c. For semiexposed backs of panels with exposed plastic-laminate surfaces, provide surface of high-pressure decorative laminate, NEMA LD 3, Grade VGS.
 - 2. Drawer Sides and Backs: Solid-hardwood lumber.
 - 3. Drawer Bottoms: Thermoset decorative panels.
- J. Drawer Construction: Fabricate with exposed fronts fastened to subfront with mounting screws from interior of body.
 - 1. Join subfronts, backs, and sides with glued rabbeted joints supplemented by mechanical fasteners or glued dovetail joints.
- K. Colors, Patterns, and Finishes: Provide materials and products that result in colors and textures of exposed laminate surfaces complying with the following requirements:
 - 1. As selected by Architect from laminate manufacturer's full range in the following categories:
 - a. Solid colors, matte finish.
 - b. Solid colors with core same color as surface, matte finish.
 - c. Wood grains, matte finish.
 - d. Patterns, matte finish.

2.2 WOOD MATERIALS

- A. Wood Products: Provide materials that comply with requirements of referenced quality standard for each type of woodwork and quality grade specified unless otherwise indicated.
 - 1. Wood Moisture Content: 5 to 10 percent.
- B. Composite Wood and Agrifiber Products: Provide materials that comply with requirements of referenced quality standard for each type of woodwork and quality grade specified unless otherwise indicated.
 - 1. Medium-Density Fiberboard: ANSI A208.2, .
 - 2. Softwood Plywood: DOC PS 1, medium-density overlay.
 - 3. Thermoset Decorative Panels: Particleboard or medium-density fiberboard finished with thermally fused, melamine-impregnated decorative paper and complying with requirements of NEMA LD 3, Grade VGL, for test methods 3.3, 3.4, 3.6, 3.8, and 3.10.

2.3 CABINET HARDWARE AND ACCESSORIES

- A. General: Provide cabinet hardware and accessory materials associated with architectural cabinets except for items specified in Section 087111 "Door Hardware (Descriptive Specification)."
- B. Frameless Concealed Hinges (European Type): BHMA A156.9, B01602, 100 degrees of opening, self-closing.
- C. Back-Mounted Pulls: BHMA A156.9, B02011.
- D. Shelf Rests: BHMA A156.9, B04013; metal.
- E. Drawer Slides: BHMA A156.9.
 - 1. Grade 1 and Grade 2: Side mounted and extending under bottom edge of drawer; full-extension type; zinc-plated steel with polymer rollers.
 - 2. Grade 1HD-100 and Grade 1HD-200: Side mounted; full-extension type; zinc-plated-steel ball-bearing slides.
 - 3. For drawers not more than 3 inches high and not more than 24 inches wide, provide Grade 2.
 - 4. For drawers more than 3 inches high but not more than 6 inches high and not more than 24 inches wide, provide Grade 1.
 - 5. For drawers more than 6 inches high or more than 24 inches wide, provide Grade 1HD-100.
 - 6. For computer keyboard shelves, provide Grade 1.
- F. Door and Drawer Silencers: BHMA A156.16, L03011.
- G. Exposed Hardware Finishes: For exposed hardware, provide finish that complies with BHMA A156.18 for BHMA finish number indicated.
 - 1. Dark, Oxidized, Satin Bronze, Oil Rubbed: BHMA 613 for bronze base; BHMA 640 for steel base; match Architect's sample.
 - 2. Bright Brass, Clear Coated: BHMA 605 for brass base; BHMA 632 for steel base.
 - 3. Bright Brass, Vacuum Coated: BHMA 723 for brass base; BHMA 729 for zinc-coated-steel base.
 - 4. Satin Brass, Blackened, Bright Relieved, Clear Coated: BHMA 610 for brass base; BHMA 636 for steel base.
 - 5. Satin Chromium Plated: BHMA 626 for brass or bronze base; BHMA 652 for steel base.

6. Bright Chromium Plated: BHMA 625 for brass or bronze base; BHMA 651 for steel base.
7. Satin Stainless Steel: BHMA 630.

H. For concealed hardware, provide manufacturer's standard finish that complies with product class requirements in BHMA A156.9.

2.4 MISCELLANEOUS MATERIALS

A. Furring, Blocking, Shims, and Hanging Strips: Softwood or hardwood lumber, kiln dried to less than 15 percent moisture content.

B. Adhesive for Bonding Plastic Laminate: Contact cement.

1. Adhesive for Bonding Edges: Hot-melt adhesive or adhesive specified above for faces.

2.5 FABRICATION

A. Fabricate cabinets to dimensions, profiles, and details indicated.

B. Complete fabrication, including assembly and hardware application, to maximum extent possible before shipment to Project site. Disassemble components only as necessary for shipment and installation. Where necessary for fitting at site, provide ample allowance for scribing, trimming, and fitting.

1. Notify Architect seven days in advance of the dates and times woodwork fabrication will be complete.
2. Trial fit assemblies at fabrication shop that cannot be shipped completely assembled. Install dowels, screws, bolted connectors, and other fastening devices that can be removed after trial fitting. Verify that various parts fit as intended and check measurements of assemblies against field measurements before disassembling for shipment.

C. Shop-cut openings to maximum extent possible to receive hardware, appliances, electrical work, and similar items. Locate openings accurately and use templates or roughing-in diagrams to produce accurately sized and shaped openings. Sand edges of cutouts to remove splinters and burrs.

PART 3 - EXECUTION

3.1 PREPARATION

A. Before installation, condition cabinets to average prevailing humidity conditions in installation areas.

B. Before installing cabinets, examine shop-fabricated work for completion and complete work as required.

3.2 INSTALLATION

A. Grade: Install cabinets to comply with same grade as item to be installed.

B. Assemble cabinets and complete fabrication at Project site to the extent that it was not completed in the shop.

- C. Install cabinets level, plumb, true, and straight. Shim as required with concealed shims. Install level and plumb to a tolerance of 1/8 inch in 96 inches.
- D. Scribe and cut cabinets to fit adjoining work, refinish cut surfaces, and repair damaged finish at cuts.
- E. Cabinets: Install without distortion so doors and drawers fit openings properly and are accurately aligned. Adjust hardware to center doors and drawers in openings and to provide unencumbered operation. Complete installation of hardware and accessory items as indicated.
 - 1. Install cabinets with no more than 1/8 inch in 96-inch sag, bow, or other variation from a straight line.
 - 2. Fasten wall cabinets through back, near top and bottom, and at ends not more than 16 inches o.c. with No. 10 wafer-head sheet metal screws through metal backing or metal framing behind wall finish.

3.3 ADJUSTING AND CLEANING

- A. Repair damaged and defective cabinets, where possible, to eliminate functional and visual defects; where not possible to repair, replace woodwork. Adjust joinery for uniform appearance.
- B. Clean, lubricate, and adjust hardware.
- C. Clean cabinets on exposed and semiexposed surfaces.

END OF SECTION 064116

SECTION 072100 - THERMAL INSULATION

PART 1 - GENERAL

1.1 RELATED DOCUMENTS

- A. Drawings and general provisions of the Contract, including General and Supplementary Conditions and Division 01 Specification Sections, apply to this Section.

1.2 SUMMARY

- A. Section Includes:
 - 1. Foam-plastic board insulation.
 - 2. Mineral-wool board insulation.
 - 3. Glass-fiber blanket insulation.
 - 4. Mineral-wool blanket insulation.

1.3 ACTION SUBMITTALS

- A. Product Data: For each type of product indicated.
- B. Product Test Reports: Based on evaluation of comprehensive tests performed by a qualified testing agency, for each product.
- C. Research/Evaluation Reports: For foam-plastic insulation, from ICC-ES.

1.4 QUALITY ASSURANCE

- A. Surface-Burning Characteristics: As determined by testing identical products according to ASTM E 84 by a qualified testing agency. Identify products with appropriate markings of applicable testing agency.

1.5 DELIVERY, STORAGE, AND HANDLING

- A. Protect insulation materials from physical damage and from deterioration due to moisture, soiling, and other sources. Store inside and in a dry location. Comply with manufacturer's written instructions for handling, storing, and protecting during installation.
- B. Protect foam-plastic board insulation as follows:
 - 1. Do not expose to sunlight except to necessary extent for period of installation and concealment.
 - 2. Protect against ignition at all times. Do not deliver foam-plastic board materials to Project site before installation time.
 - 3. Quickly complete installation and concealment of foam-plastic board insulation in each area of construction.

PART 2 - PRODUCTS

2.1 FOAM-PLASTIC BOARD INSULATION

- A. Extruded-Polystyrene Board Insulation: ASTM C 578, of type and minimum compressive strength indicated below, with maximum flame-spread and smoke-developed indexes of 75 and 450, respectively, per ASTM E 84.
1. Manufacturers: Subject to compliance with requirements, available manufacturers offering products that may be incorporated into the Work include, but are not limited to, the following:
 - a. Dow Chemical Company (The).
 - b. Owens Corning.
 - c. Pactiv Building Products.
 2. Type VI, 40 psi.
 3. Thermal resistivity: R-5 / inch.
- B. Adhesive for Bonding Insulation: Product with demonstrated capability to bond insulation securely to substrates without damaging insulation and substrates.

2.2 GLASS-FIBER BOARD INSULATION

- A. Manufacturers: Subject to compliance with requirements, provide products by one of the following:
1. CertainTeed Corporation.
 2. Johns Manville.
 3. Knauf Insulation.
 4. Owens Corning, CW 225 (Basis-of-Design).
- B. Unfaced, Glass-Fiber Board Insulation: ASTM C 612, Type IA; with maximum flame-spread and smoke-developed indexes of 25 and 50, respectively, per ASTM E 84, passing ASTM E 136 for combustion characteristics.
1. Nominal density of 2.25 lb/cu. ft., thermal resistivity of 4.3 deg F x h x sq. ft./Btu x in. at 75 deg F.
 - ?. Nominal density of 6 lb/cu. ft., thermal resistivity of 4.5 deg F x h x sq. ft./Btu x in. at 75 deg F.

2.3 MINERAL-WOOL BOARD INSULATION

- A. Manufacturers: Subject to compliance with requirements, provide products by one of the following:
1. Fibrex Insulations Inc.
 2. Owens Corning.
 3. Thermafiber.
- B. Unfaced, Mineral-Wool Board Insulation: ASTM C 612; with maximum flame-spread and smoke-developed indexes of 15 and zero, respectively, per ASTM E 84; passing ASTM E 136 for combustion characteristics.

1. Nominal density of 6 lb/cu. ft., Type II, thermal resistivity of 4.16 deg F x h x sq. ft./Btu x in. at 75 deg F.
2. Fiber Color: Darkened, where indicated.

2.4 GLASS-FIBER BLANKET INSULATION

- A. Manufacturers: Subject to compliance with requirements, provide products by one of the following:
1. CertainTeed Corporation.
 2. Johns Manville.
 3. Knauf Insulation.
 4. Owens Corning.
- B. Unfaced, Glass-Fiber Blanket Insulation: ASTM C 665, Type I; with maximum flame-spread and smoke-developed indexes of 25 and 50, respectively, per ASTM E 84; passing ASTM E 136 for combustion characteristics.

2.5 MINERAL-WOOL BLANKET INSULATION

- A. Manufacturers: Subject to compliance with requirements, provide products by one of the following:
1. Fibrex Insulations Inc.
 2. Owens Corning.
 3. Roxul Inc.
 4. Thermafiber. Basis-of-Design Product: "SAFB"
- B. Unfaced, Mineral-Wool Blanket Insulation: ASTM C 665, Type I (blankets without membrane facing); consisting of fibers; with maximum flame-spread and smoke-developed indexes of 25 and 50, respectively, per ASTM E 84; passing ASTM E 136 for combustion characteristics.
1. Nominal density of 3 lb/cu. ft
 2. Stud walls: Oversized, creased blankets for snug fit between studs.

2.6 SPRAY POLYURETHANE FOAM INSULATION

- A. Closed-Cell Polyurethane Foam Insulation: ASTM C 1029, Type II, with maximum flame-spread and smoke-developed indexes of 75 and 450, respectively, per ASTM E 84.
1. Manufacturers: Subject to compliance with requirements, provide products by one of the following:
 - a. BASF Corporation.
 - b. Dow Chemical Company (The).
 - c. Henry Company.
 2. Minimum density of 1.5 lb/cu. ft., thermal resistivity of 6.2 deg F x h x sq. ft./Btu x in. at 75 deg F.

2.7 INSULATION FASTENERS

- A. Adhesively Attached, Spindle-Type Anchors: Plate welded to projecting spindle; capable of holding insulation of specified thickness securely in position indicated with self-locking washer in place.
 - 1. Plate: Perforated, galvanized carbon-steel sheet, 0.030 inch thick by 2 inches square.
 - 2. Spindle: Copper-coated, low-carbon steel; fully annealed; 0.105 inch in diameter; length to suit depth of insulation indicated.
- B. Insulation-Retaining Washers: Self-locking washers formed from 0.016-inch- thick galvanized-steel sheet, with beveled edge for increased stiffness, sized as required to hold insulation securely in place, but not less than 1-1/2 inches square or in diameter.
 - 1. Protect ends with capped self-locking washers incorporating a spring steel insert to ensure permanent retention of cap in the following locations:
 - a. Ceiling plenums.
 - b. Where indicated.
- C. Anchor Adhesive: Product with demonstrated capability to bond insulation anchors securely to substrates indicated without damaging insulation, fasteners, and substrates.

PART 3 - EXECUTION

3.1 PREPARATION

- A. Clean substrates of substances that are harmful to insulation or that interfere with insulation attachment.

3.2 INSTALLATION, GENERAL

- A. Comply with insulation manufacturer's written instructions applicable to products and applications indicated.
- B. Install insulation that is undamaged, dry, and unsoiled and that has not been left exposed to ice, rain, or snow at any time.
- C. Extend insulation to envelop entire area to be insulated. Cut and fit tightly around obstructions and fill voids with insulation. Remove projections that interfere with placement.
 - 1. Install spray polyurethane insulation in same thickness as rigid board insulation at perimeter, penetrations, and termination to adjacent elements.
- D. Provide sizes to fit applications indicated and selected from manufacturer's standard thicknesses, widths, and lengths. Apply single layer of insulation units to produce thickness indicated unless multiple layers are otherwise shown or required to make up total thickness.

3.3 INSTALLATION OF CAVITY-WALL INSULATION

- A. Foam-Plastic Board Insulation: Install pads of adhesive spaced approximately 24 inches o.c. both ways on inside face, and as recommended by manufacturer. Fit courses of insulation between wall ties and other obstructions, with edges butted tightly in both directions. Press units firmly against inside substrates.

1. Supplement adhesive attachment of insulation by securing boards with two-piece wall ties designed for this purpose and specified in Division 04 Section "Unit Masonry."
- B. Acoustical Batt Insulation: Install batts over spindle-type anchors spaced at approximately 24" o.c. with insulation-retaining washers. secure batt insulation securely against on side of the cavity. Trim spindle to face of retaining washer so as to not bridge the wall cavity.
1. Location: Interior double masonry wall.
- 3.4 INSTALLATION OF INSULATION FOR FRAMED CONSTRUCTION
- A. Apply insulation units to substrates by method indicated, complying with manufacturer's written instructions. If no specific method is indicated, bond units to substrate with adhesive or use mechanical anchorage to provide permanent placement and support of units.
- B. Foam-Plastic Board Insulation: Seal joints between units by applying adhesive, mastic, or sealant to edges of each unit to form a tight seal as units are shoved into place. Fill voids in completed installation with adhesive, mastic, spray-applied insulation, or sealant as recommended by insulation manufacturer.
- C. Glass-Fiber or Mineral-Wool Blanket Insulation: Install in cavities formed by framing members according to the following requirements:
1. Use insulation widths and lengths that fill the cavities formed by framing members. If more than one length is required to fill the cavities, provide lengths that will produce a snug fit between ends.
 2. Place insulation in cavities formed by framing members to produce a friction fit between edges of insulation and adjoining framing members.
 3. Maintain 3-inch clearance of insulation around recessed lighting fixtures not rated for or protected from contact with insulation.
 4. For metal-framed wall cavities where cavity heights exceed 96 inches, support unfaced blankets mechanically and support faced blankets by taping flanges of insulation to flanges of metal studs.
 5. Hold blankets to one side of wall cavity, in full contact with wallboard.
- D. Spray-Applied Insulation: Apply spray-applied insulation according to manufacturer's written instructions. Do not apply insulation until installation of pipes, ducts, conduits, wiring, and electrical outlets in walls is completed and windows, electrical boxes, and other items not indicated to receive insulation are masked. After insulation is applied, make flush with face of studs by using method recommended by insulation manufacturer.
- E. Miscellaneous Voids: Install insulation in miscellaneous voids and cavity spaces where required to prevent gaps in insulation using the following materials:
1. Loose-Fill Insulation: Compact to approximately 40 percent of normal maximum volume equaling a density of approximately 2.5 lb/cu. ft..
 2. Spray Polyurethane Insulation: Apply according to manufacturer's written instructions.
 - a. Do not apply insulation until installation of pipes, ducts, conduits, wiring, and electrical outlets in walls is completed and windows, electrical boxes, and other items not indicated to receive insulation are masked. After insulation is applied, make flush with face of studs by using method recommended by insulation manufacturer.

3.5 INSTALLATION OF INSULATION FOR CONCRETE SUBSTRATES

- A. Install board insulation on concrete substrates by adhesively attached, spindle-type insulation anchors as follows:
 - 1. Fasten insulation anchors to concrete substrates with insulation anchor adhesive according to anchor manufacturer's written instructions. Space anchors according to insulation manufacturer's written instructions for insulation type, thickness, and application indicated.
 - 2. After adhesive has dried, install board insulation by pressing insulation into position over spindles and securing it tightly in place with insulation-retaining washers, taking care not to compress insulation below indicated thickness.
 - 3. Where insulation will not be covered by other building materials, apply capped washers to tips of spindles.

3.6 INSTALLATION OF CURTAIN-WALL INSULATION

- A. Install board insulation in curtain-wall construction where indicated on Drawings according to curtain-wall manufacturer's written instructions.
 - 1. Hold insulation in place by securing metal clips and straps or integral pockets within window frames, spaced at intervals recommended in writing by insulation manufacturer to hold insulation securely in place without touching spandrel glass. Maintain cavity width of dimension indicated between insulation and glass.
 - 2. Install insulation where it contacts perimeter fire-containment system to prevent insulation from bowing under pressure from perimeter fire-containment system.

3.7 INSTALLATION OF VAPOR RETARDERS

- A. Place vapor retarders on side of construction indicated on Drawings. Extend vapor retarders to extremities of areas to protect from vapor transmission. Secure vapor retarders in place with adhesives or other anchorage system as indicated. Extend vapor retarders to cover miscellaneous voids in insulated substrates, including those filled with loose-fiber insulation.
- B. Seal joints caused by pipes, conduits, electrical boxes, and similar items penetrating vapor retarders with vapor-retarder tape to create an airtight seal between penetrating objects and vapor retarders.
- C. Repair tears or punctures in vapor retarders immediately before concealment by other work. Cover with vapor-retarder tape or another layer of vapor retarders.

3.8 PROTECTION

- A. Protect installed insulation and vapor retarders from damage due to harmful weather exposures, physical abuse, and other causes. Provide temporary coverings or enclosures where insulation is subject to abuse and cannot be concealed and protected by permanent construction immediately after installation.

3.9 INSULATION SCHEDULE

- A. Batt Insulation : Unfaced, Glass-Fiber Blanket insulation.
- B. Acoustical Batt Insulation: Unfaced 3# density, Mineral-Wool Blanket Insulation.

- C. Spray- Applied Insulation : Spray Polyurethane Foam Insulation.

END OF SECTION 072100

SECTION 075423 - THERMOPLASTIC POLYOLEFIN (TPO) ROOFING

PART 1 - GENERAL

1.1 RELATED DOCUMENTS

- A. Drawings and general provisions of the Contract, including General and Supplementary Conditions and Division 01 Specification Sections, apply to this Section.

1.2 SUMMARY

- A. Section Includes:
 - 1. Mechanically fastened TPO membrane roofing system.
 - 2. Roof insulation.
- B. Related Sections:
 - 1. Division 07 Section "Thermal Insulation" for insulation beneath the roof deck.
 - 2. Division 07 Section "Sheet Metal Flashing and Trim" for metal roof penetration flashings, flashings, and counterflashings.

1.3 DEFINITIONS

- A. TPO: Thermoplastic polyolefin.
- B. Roofing Terminology: See ASTM D 1079 and glossary in NRCA's "The NRCA Roofing and Waterproofing Manual" for definitions of terms related to roofing work in this Section.

1.4 PERFORMANCE REQUIREMENTS

- A. General Performance: Installed membrane roofing and base flashings shall withstand specified uplift pressures, thermally induced movement, and exposure to weather without failure due to defective manufacture, fabrication, installation, or other defects in construction. Membrane roofing and base flashings shall remain watertight.
- B. Material Compatibility: Provide roofing materials that are compatible with one another under conditions of service and application required, as demonstrated by membrane roofing manufacturer based on testing and field experience.
- C. Roofing System Design: Provide membrane roofing system that is identical to systems that have been successfully tested by a qualified testing and inspecting agency to resist uplift pressure calculated according to ASCE/SEI 7 for the project's location and wind loads indicated on the structural drawings.
- D. FM Approvals Listing: Provide membrane roofing, base flashings, and component materials that comply with requirements in FM Approvals 4450 and FM Approvals 4470 as part of a membrane roofing system, and that are listed in FM Approvals' "RoofNav" for Class 1 or noncombustible construction, as applicable. Identify materials with FM Approvals markings.
 - 1. Fire/Windstorm Classification: Class 1A-90.
 - 2. Hail Resistance: MH.

- E. Solar Reflectance Index: Not less than 78 when calculated according to ASTM E 1980, based on testing identical products by a qualified testing agency.
- F. Energy Performance: Provide roofing system that is listed on the DOE's ENERGY STAR "Roof Products Qualified Product List" for low -slope roof products.

1.5 ACTION SUBMITTALS

- A. Product Data: For each type of product indicated.
- B. Shop Drawings: For roofing system. Include plans, elevations, sections, details, and attachments to other work.
 - 1. Base flashings and membrane terminations.
 - 2. Tapered insulation, including slopes.
 - 3. Insulation fastening patterns for corner, perimeter, and field-of-roof locations.
- C. Samples for Verification: For the following products:
 - 1. Sheet roofing, of color specified, including T-shaped side and end lap seam.
 - 2. Roof insulation.

1.6 INFORMATIONAL SUBMITTALS

- A. Qualification Data: For qualified Installer and manufacturer.
- B. An employer of workers trained and approved by manufacturer, and with a minimum of five (5) years experience in the installation of metal roofing that is approved, authorized, or licensed by the metal roof panel manufacturer to install the product and that is eligible to receive manufacturer's special warranty
- C. Manufacturer Certificates: Signed by roofing manufacturer certifying that roofing system complies with requirements specified in "Performance Requirements" Article.
 - 1. Submit evidence of compliance with performance requirements.
- D. Research/Evaluation Reports: For components of membrane roofing system, from the ICC-ES.
- E. Field quality-control reports.
- F. Warranties: Sample of special warranties.

1.7 CLOSEOUT SUBMITTALS

- A. Maintenance Data: For roofing system to include in maintenance manuals.

1.8 QUALITY ASSURANCE

- A. Manufacturer Qualifications: A qualified manufacturer that is FM Approvals approved for membrane roofing system identical to that used for this Project.
- B. Installer Qualifications: A qualified firm that is approved, authorized, or licensed by membrane roofing system manufacturer to install manufacturer's product and that is eligible to receive manufacturer's special warranty.

- C. Source Limitations: Obtain components including roof insulation, fasteners, and necessary related accessories for membrane roofing system from same manufacturer as membrane roofing or approved by membrane roofing manufacturer.
 - D. Exterior Fire-Test Exposure: ASTM E 108, Class C; for application and roof slopes indicated, as determined by testing identical membrane roofing materials by a qualified testing agency. Materials shall be identified with appropriate markings of applicable testing agency.
 - E. Preliminary Roofing Conference: Before starting roof deck construction, conduct conference at Project site.
 - 1. Meet with Owner, Architect, Owner's insurer if applicable, testing and inspecting agency representative, roofing Installer, roofing system manufacturer's representative, deck Installer, and installers whose work interfaces with or affects roofing, including installers of roof accessories and roof-mounted equipment.
 - 2. Review methods and procedures related to roofing installation, including manufacturer's written instructions.
 - 3. Review deck substrate requirements for conditions and finishes, including flatness and fastening.
 - 4. Review structural loading limitations of roof deck during and after roofing.
 - 5. Review base flashings, special roofing details, roof drainage, roof penetrations, equipment curbs, and condition of other construction that will affect roofing system.
 - F. Preinstallation Roofing Conference: Conduct conference at Project site.
 - 1. Meet with Owner, Architect, Owner's insurer if applicable, testing and inspecting agency representative, roofing Installer, roofing system manufacturer's representative, deck Installer, and installers whose work interfaces with or affects roofing, including installers of roof accessories and roof-mounted equipment.
 - 2. Review methods and procedures related to roofing installation, including manufacturer's written instructions.
 - 3. Review and finalize construction schedule and verify availability of materials, Installer's personnel, equipment, and facilities needed to make progress and avoid delays.
 - 4. Examine deck substrate conditions and finishes for compliance with requirements, including flatness and fastening.
 - 5. Review structural loading limitations of roof deck during and after roofing.
 - 6. Review base flashings, special roofing details, roof drainage, roof penetrations, equipment curbs, and condition of other construction that will affect roofing system.
 - 7. Review governing regulations and requirements for insurance and certificates if applicable.
 - 8. Review temporary protection requirements for roofing system during and after installation.
 - 9. Review roof observation and repair procedures after roofing installation.
- 1.9 DELIVERY, STORAGE, AND HANDLING
- A. Deliver roofing materials to Project site in original containers with seals unbroken and labeled with manufacturer's name, product brand name and type, date of manufacture, approval or listing agency markings, and directions for storing and mixing with other components.
 - B. Store liquid materials in their original undamaged containers in a clean, dry, protected location and within the temperature range required by roofing system manufacturer. Protect stored liquid material from direct sunlight.
 - 1. Discard and legally dispose of liquid material that cannot be applied within its stated shelf life.
 - C. Protect roof insulation materials from physical damage and from deterioration by sunlight, moisture, soiling, and other sources. Store in a dry location. Comply with insulation manufacturer's written instructions for handling, storing, and protecting during installation.

- D. Handle and store roofing materials and place equipment in a manner to avoid permanent deflection of deck.

1.10 PROJECT CONDITIONS

- A. Weather Limitations: Proceed with installation only when existing and forecasted weather conditions permit roofing system to be installed according to manufacturer's written instructions and warranty requirements.

1.11 WARRANTY

- A. Special Warranty: Manufacturer's standard or customized form, without monetary limitation, in which manufacturer agrees to repair or replace components of membrane roofing system that fail in materials or workmanship within specified warranty period.
 - 1. Special warranty includes membrane roofing, base flashings, roof insulation, fasteners, cover boards, roofing accessories, and other components of membrane roofing system.
 - 2. Warranty Period: 25 years from date of Substantial Completion.
- B. Special Project Warranty: Submit roofing Installer's warranty, on warranty form at end of this Section, signed by Installer, covering the Work of this Section, including all components of membrane roofing system such as membrane roofing, base flashing, roof insulation, fasteners, cover boards, substrate boards, vapor retarders, roof pavers, and walkway products, for the following warranty period:
 - 1. Warranty Period: Two years from date of Substantial Completion.

PART 2 - PRODUCTS

2.1 TPO MEMBRANE ROOFING

- A. Fabric-Reinforced Thermoplastic Polyolefin Sheet: ASTM D 6878, internally fabric or scrim reinforced, uniform, flexible fabric backed TPO sheet.
 - 1. Manufacturers: Subject to compliance with requirements, provide products by one of the following:
 - a. Carlisle SynTec Incorporated.
 - b. Firestone Building Products Company.
 - c. GAF Materials Corporation.
 - d. Johns Manville.
 - e. Stevens Roofing Systems; Division of JPS Elastomers.
 - 2. Thickness: 60 mils, nominal.
 - 3. Exposed Face Color: White.

2.2 AUXILIARY MEMBRANE ROOFING MATERIALS

- A. General: Auxiliary membrane roofing materials recommended by roofing system manufacturer for intended use, and compatible with membrane roofing.
 - 1. Liquid-type auxiliary materials shall comply with VOC limits of authorities having jurisdiction.

2. Adhesives and sealants that are not on the exterior side of weather barrier shall comply with the following limits for VOC content when calculated according to 40 CFR 59, Subpart D (EPA Method 24):
 - a. Plastic Foam Adhesives: 50 g/L.
 - b. Gypsum Board and Panel Adhesives: 50 g/L.
 - c. Multipurpose Construction Adhesives: 70 g/L.
 - d. Fiberglass Adhesives: 80 g/L.
 - e. Single-Ply Roof Membrane Adhesives: 250 g/L.
 - f. Other Adhesives: 250 g/L.
 - g. Single-Ply Roof Membrane Sealants: 450 g/L.
 - h. Nonmembrane Roof Sealants: 300 g/L.
 - i. Sealant Primers for Nonporous Substrates: 250 g/L.
 - j. Sealant Primers for Porous Substrates: 775 g/L.
- B. Sheet Flashing: Manufacturer's standard unreinforced thermoplastic polyolefin sheet flashing, 55 mils thick, minimum, of same color as sheet membrane.
- C. Bonding Adhesive: Manufacturer's standard, water based.
- D. Metal Termination Bars: Manufacturer's standard, predrilled stainless-steel or aluminum bars, approximately 1 by 1/8 inch thick; with anchors.
- E. Fasteners: Factory-coated steel fasteners and metal or plastic plates complying with corrosion-resistance provisions in FM Approvals 4470, designed for fastening membrane to substrate, and acceptable to membrane roofing system manufacturer.
- F. Miscellaneous Accessories: Provide pourable sealers, preformed cone and vent sheet flashings, preformed inside and outside corner sheet flashings, T-joint covers, lap sealants, termination reglets, and other accessories.

2.3 VAPOR RETARDER

- A. Polyethylene Film: ASTM D 4397, 6 mils thick, minimum, with maximum permeance rating of 0.13 perm.
 1. Tape: Pressure-sensitive tape of type recommended by vapor-retarder manufacturer for sealing joints and penetrations in vapor retarder.
 2. Adhesive: Manufacturer's standard lap adhesive, FM Approvals approved for vapor-retarder application.

2.4 ROOF INSULATION

- A. General: Preformed roof insulation boards manufactured or approved by TPO membrane roofing manufacturer, selected from manufacturer's standard sizes suitable for application, of thicknesses indicated and that produce FM Approvals-approved roof insulation.
- B. Polyisocyanurate Board Insulation: ASTM C 1289, Type II, Class 1, Grade 2, felt or glass-fiber mat facer on both major surfaces.
- C. Provide preformed saddles, crickets, tapered edge strips, and other insulation shapes where indicated for sloping to drain. Fabricate to slopes indicated.

2.5 INSULATION ACCESSORIES

- A. General: Furnish roof insulation accessories recommended by insulation manufacturer for intended use and compatibility with membrane roofing.
- B. Fasteners: Factory-coated steel fasteners and metal or plastic plates complying with corrosion-resistance provisions in FM Approvals 4470, designed for fastening roof insulation to substrate, and acceptable to roofing system manufacturer.
- C. Full-Spread Applied Insulation Adhesive: Insulation manufacturer's recommended spray-applied, low-rise, two-component urethane adhesive formulated to attach roof insulation to substrate or to another insulation layer.
- D. Cover Board: ASTM C 1177/C 1177M, glass-mat, water-resistant gypsum substrate, 1/4 inch thick, factory primed.

PART 3 - EXECUTION

3.1 EXAMINATION

- A. Examine substrates, areas, and conditions, with Installer present, for compliance with the following requirements and other conditions affecting performance of roofing system:
 - 1. Verify that roof openings and penetrations are in place and curbs are set and braced and that roof drain bodies are securely clamped in place.
 - 2. Verify that wood blocking, curbs, and nailers are securely anchored to roof deck at penetrations and terminations and that nailers match thicknesses of insulation.
 - 3. Verify that surface plane flatness and fastening of steel roof deck complies with requirements in Division 05 Section "Steel Decking."
 - 4. Verify that minimum concrete drying period recommended by roofing system manufacturer has passed.
 - 5. Verify that concrete substrate is visibly dry and free of moisture. Test for capillary moisture by plastic sheet method according to ASTM D 4263.
 - 6. Verify that concrete curing compounds that will impair adhesion of roofing components to roof deck have been removed.
- B. Proceed with installation only after unsatisfactory conditions have been corrected.

3.2 PREPARATION

- A. Clean substrate of dust, debris, moisture, and other substances detrimental to roofing installation according to roofing system manufacturer's written instructions. Remove sharp projections.
- B. Prevent materials from entering and clogging roof drains and conductors and from spilling or migrating onto surfaces of other construction. Remove roof-drain plugs when no work is taking place or when rain is forecast.
- C. Complete terminations and base flashings and provide temporary seals to prevent water from entering completed sections of roofing system at the end of the workday or when rain is forecast. Remove and discard temporary seals before beginning work on adjoining roofing.

3.3 VAPOR-RETARDER INSTALLATION

- A. Polyethylene Film: Loosely lay polyethylene-film vapor retarder in a single layer over area to receive vapor retarder, side and end lapping each sheet a minimum of 2 inches and 6 inches, respectively.
 - 1. Continuously seal side and end laps with tape.

3.4 INSULATION INSTALLATION

- A. Coordinate installing membrane roofing system components so insulation is not exposed to precipitation or left exposed at the end of the workday.
- B. Comply with membrane roofing system and insulation manufacturer's written instructions for installing roof insulation.
- C. Install tapered insulation under area of roofing to conform to slopes indicated.
- D. Install insulation under area of roofing to achieve required thickness. Where overall insulation thickness is 2.7 inches or greater, install two or more layers with joints of each succeeding layer staggered from joints of previous layer a minimum of 6 inches in each direction.
 - 1. Where installing composite and noncomposite insulation in two or more layers, install noncomposite board insulation for bottom layer and intermediate layers, if applicable, and install composite board insulation for top layer.
- E. Trim surface of insulation where necessary at roof drains so completed surface is flush and does not restrict flow of water.
- F. Install insulation with long joints of insulation in a continuous straight line with end joints staggered between rows, abutting edges and ends between boards. Fill gaps exceeding 1/4 inch with insulation.
 - 1. Cut and fit insulation within 1/4 inch of nailers, projections, and penetrations.
 - 2. Adhere insulation over concrete roof decks.
- G. Mechanically Fastened Insulation: Install each layer of insulation and secure to deck using mechanical fasteners specifically designed and sized for fastening specified board-type roof insulation to deck type.
 - 1. Fasten insulation to resist uplift pressure at corners, perimeter, and field of roof.
 - 2. Mechanically fasten insulation over metal roof decks.
- H. Install cover boards over insulation with long joints in continuous straight lines with end joints staggered between rows. Offset joints of insulation below a minimum of 6 inches in each direction. Loosely butt cover boards together.
 - 1. Fasten cover boards to resist uplift pressure at corners, perimeter, and field of roof.

3.5 ADHERED MEMBRANE ROOFING INSTALLATION

- A. Adhere membrane roofing over area to receive roofing and install according to membrane roofing system manufacturer's written instructions.
 - 1. Fully adhere insulation and roofing over concrete roof decks.

- B. Start installation of membrane roofing in presence of membrane roofing system manufacturer's technical personnel.
- C. Bonding Adhesive: Apply to substrate and underside of membrane roofing at rate required by manufacturer and allow to partially dry before installing membrane roofing. Do not apply to splice area of membrane roofing.
- D. Apply membrane roofing with side laps shingled with slope of roof deck where possible.
- E. Seams: Clean seam areas, overlap membrane roofing, and hot-air weld side and end laps of membrane roofing and sheet flashings according to manufacturer's written instructions to ensure a watertight seam installation.
 - 1. Test lap edges with probe to verify seam weld continuity. Apply lap sealant to seal cut edges of sheet membrane.
 - 2. Verify field strength of seams a minimum of twice daily and repair seam sample areas.
 - 3. Repair tears, voids, and lapped seams in roofing that does not comply with requirements.
- F. Spread sealant bed over deck drain flange at roof drains and securely seal membrane roofing in place with clamping ring.
- G. Flood Test entire deck area to receive paver system.

3.6 MECHANICALLY FASTENED MEMBRANE ROOFING INSTALLATION

- A. Mechanically fasten membrane roofing over area to receive roofing and install according to roofing system manufacturer's written instructions.
 - 1. Mechanically fasten roofing system over metal roof decks.
 - 2. For in-splice attachment, install membrane roofing with long dimension perpendicular to steel roof deck flutes.
- B. Start installation of membrane roofing in presence of roofing system manufacturer's technical personnel.
- C. Accurately align membrane roofing and maintain uniform side and end laps of minimum dimensions required by manufacturer. Stagger end laps.
- D. Mechanically fasten or adhere membrane roofing securely at terminations, penetrations, and perimeter of roofing.
- E. Apply membrane roofing with side laps shingled with slope of roof deck where possible.
- F. Seams: Clean seam areas, overlap membrane roofing, and hot-air weld side and end laps of membrane roofing and sheet flashings according to manufacturer's written instructions to ensure a watertight seam installation.
 - 1. Test lap edges with probe to verify seam weld continuity. Apply lap sealant to seal cut edges of sheet membrane.
 - 2. Verify field strength of seams a minimum of twice daily and repair seam sample areas.
 - 3. Repair tears, voids, and lapped seams in roofing that does not comply with requirements.
- G. Spread sealant bed over deck drain flange at roof drains and securely seal membrane roofing in place with clamping ring.

3.7 BASE FLASHING INSTALLATION

- A. Install sheet flashings and preformed flashing accessories and adhere to substrates according to membrane roofing system manufacturer's written instructions.
- B. Apply bonding adhesive to substrate and underside of sheet flashing at required rate and allow to partially dry. Do not apply to seam area of flashing.
- C. Flash penetrations and field-formed inside and outside corners with cured or uncured sheet flashing.
- D. Clean seam areas, overlap, and firmly roll sheet flashings into the adhesive. Hot-air weld side and end laps to ensure a watertight seam installation.
- E. Terminate and seal top of sheet flashings and mechanically anchor to substrate through termination bars.

3.8 WALKWAY INSTALLATION

- A. Flexible Walkways: Install walkway products in locations indicated. Heat weld to substrate or adhere walkway products to substrate with compatible adhesive according to roofing system manufacturer's written instructions.

3.9 FIELD QUALITY CONTROL

- A. Testing Agency: Engage a qualified testing agency to perform tests and inspections.
- B. Final Roof Inspection: Arrange for roofing system manufacturer's technical personnel to inspect roofing installation on completion.
- C. Repair or remove and replace components of membrane roofing system where inspections indicate that they do not comply with specified requirements.
- D. Additional inspections, at Contractor's expense, will be performed to determine compliance of replaced or additional work with specified requirements.

3.10 PROTECTING AND CLEANING

- A. Protect membrane roofing system from damage and wear during remainder of construction period. When remaining construction will not affect or endanger roofing, inspect roofing for deterioration and damage, describing its nature and extent in a written report, with copies to Architect and Owner.
- B. Correct deficiencies in or remove membrane roofing system that does not comply with requirements; repair substrates; and repair or reinstall membrane roofing system to a condition free of damage and deterioration at time of Substantial Completion and according to warranty requirements.

3.11 ROOFING INSTALLER'S WARRANTY

- A. WHEREAS Insert name of Insert address, herein called the "Roofing Installer," has performed roofing and associated work ("work") on the following project:

- 1. Owner: Insert name of Owner.

2. Address: Insert address.
 3. Building Name/Type: Insert information.
 4. Address: Insert address.
 5. Area of Work: Insert information.
 6. Acceptance Date: Insert date.
 7. Warranty Period: Insert time.
 8. Expiration Date: Insert date.
- B. AND WHEREAS Roofing Installer has contracted (either directly with Owner or indirectly as a subcontractor) to warrant said work against leaks and faulty or defective materials and workmanship for designated Warranty Period,
- C. NOW THEREFORE Roofing Installer hereby warrants, subject to terms and conditions herein set forth, that during Warranty Period he will, at his own cost and expense, make or cause to be made such repairs to or replacements of said work as are necessary to correct faulty and defective work and as are necessary to maintain said work in a watertight condition.
- D. This Warranty is made subject to the following terms and conditions:
1. Specifically excluded from this Warranty are damages to work and other parts of the building, and to building contents, caused by:
 - a. Lightning;
 - b. Peak gust wind speed exceeding _____ mph;
 - c. Fire;
 - d. Failure of roofing system substrate, including cracking, settlement, excessive deflection, deterioration, and decomposition;
 - e. Faulty construction of parapet walls, copings, chimneys, skylights, vents, equipment supports, and other edge conditions and penetrations of the work;
 - f. Vapor condensation on bottom of roofing; and
 - g. Activity on roofing by others, including construction contractors, maintenance personnel, other persons, and animals, whether authorized or unauthorized by Owner.
 2. When work has been damaged by any of foregoing causes, Warranty shall be null and void until such damage has been repaired by Roofing Installer and until cost and expense thereof have been paid by Owner or by another responsible party so designated.
 3. Roofing Installer is responsible for damage to work covered by this Warranty but is not liable for consequential damages to building or building contents resulting from leaks or faults or defects of work.
 4. During Warranty Period, if Owner allows alteration of work by anyone other than Roofing Installer, including cutting, patching, and maintenance in connection with penetrations, attachment of other work, and positioning of anything on roof, this Warranty shall become null and void on date of said alterations, but only to the extent said alterations affect work covered by this Warranty. If Owner engages Roofing Installer to perform said alterations, Warranty shall not become null and void unless Roofing Installer, before starting said work, shall have notified Owner in writing, showing reasonable cause for claim, that said alterations would likely damage or deteriorate work, thereby reasonably justifying a limitation or termination of this Warranty.
 5. During Warranty Period, if original use of roof is changed and it becomes used for, but was not originally specified for, a promenade, work deck, spray-cooled surface, flooded basin, or other use or service more severe than originally specified, this Warranty shall become null and void on date of said change, but only to the extent said change affects work covered by this Warranty.
 6. Owner shall promptly notify Roofing Installer of observed, known, or suspected leaks, defects, or deterioration and shall afford reasonable opportunity for Roofing Installer to inspect work and to examine evidence of such leaks, defects, or deterioration.

7. This Warranty is recognized to be the only warranty of Roofing Installer on said work and shall not operate to restrict or cut off Owner from other remedies and resources lawfully available to Owner in cases of roofing failure. Specifically, this Warranty shall not operate to relieve Roofing Installer of responsibility for performance of original work according to requirements of the Contract Documents, regardless of whether Contract was a contract directly with Owner or a subcontract with Owner's General Contractor.

E. IN WITNESS THEREOF, this instrument has been duly executed this Insert day day of Insert month, Insert year.

1. Authorized Signature: Insert signature.
2. Name: Insert name.
3. Title: Insert title.

END OF SECTION 075423

SECTION 076200 - SHEET METAL FLASHING AND TRIM

PART 1 - GENERAL

1.1 RELATED DOCUMENTS

- A. Drawings and general provisions of the Contract, including General and Supplementary Conditions and Division 01 Specification Sections, apply to this Section.

1.2 SUMMARY

- A. Section Includes:
 - 1. Manufactured Products:
 - a. Manufactured through-wall flashing and counterflashing.
 - b. Manufactured reglets and counterflashing.
 - 2. Formed Products:
 - a. Formed roof drainage sheet metal fabrications.
 - b. Formed low-slope roof sheet metal fabrications.
 - c. Formed steep-slope roof sheet metal fabrications.
 - d. Formed wall sheet metal fabrications.

1.3 PERFORMANCE REQUIREMENTS

- A. General: Sheet metal flashing and trim assemblies as indicated shall withstand wind loads, structural movement, thermally induced movement, and exposure to weather without failure due to defective manufacture, fabrication, installation, or other defects in construction. Completed sheet metal flashing and trim shall not rattle, leak, or loosen, and shall remain watertight.
- B. Thermal Movements: Provide sheet metal flashing and trim that allows for thermal movements from ambient and surface temperature changes.
 - 1. Temperature Change (Range): 120 deg F, ambient; 180 deg F, material surfaces.

1.4 ACTION SUBMITTALS

- A. Product Data: For each type of product indicated. Include construction details, material descriptions, dimensions of individual components and profiles, and finishes for each manufactured product and accessory.
- B. Shop Drawings: Show fabrication and installation layouts of sheet metal flashing and trim, including plans, elevations, expansion-joint locations, and keyed details. Distinguish between shop- and field-assembled work. Include the following:
 - 1. Identification of material, thickness, weight, and finish for each item and location in Project.
 - 2. Details for forming sheet metal flashing and trim, including profiles, shapes, seams, and dimensions.

3. Details for joining, supporting, and securing sheet metal flashing and trim, including layout of fasteners, cleats, clips, and other attachments. Include pattern of seams.
4. Details of termination points and assemblies, including fixed points.
5. Details of expansion joints and expansion-joint covers, including showing direction of expansion and contraction.
6. Details of edge conditions, including eaves, ridges, valleys, rakes, crickets, and counterflashings as applicable.
7. Details of special conditions.
8. Details of connections to adjoining work.
9. Details of expansion provisions for long runs of metal flashing.
10. Detail formed flashing and trim at a scale of not less than 1-1/2 inches per 12 inches.

C. Samples for Verification: For each type of exposed finish required, prepared on Samples of size indicated below if requested by Architect:

1. Trim, Metal Closures, Expansion Joints, Joint Intersections, and Miscellaneous Fabrications: 12 inches long and in required profile. Include fasteners and other exposed accessories.

1.5 INFORMATIONAL SUBMITTALS

A. Qualification Data: For qualified fabricator.

1.6 QUALITY ASSURANCE

- A. Fabricator Qualifications: Shop that employs skilled workers who custom fabricate sheet metal flashing and trim similar to that required for this Project and whose products have a record of successful in-service performance.
- B. Sheet Metal Flashing and Trim Standard: Comply with SMACNA's "Architectural Sheet Metal Manual" unless more stringent requirements are specified or shown on Drawings.

1.7 DELIVERY, STORAGE, AND HANDLING

- A. Do not store sheet metal flashing and trim materials in contact with other materials that might cause staining, denting, or other surface damage. Store sheet metal flashing and trim materials away from uncured concrete and masonry.
- B. Protect strippable protective covering on sheet metal flashing and trim from exposure to sunlight and high humidity, except to the extent necessary for the period of sheet metal flashing and trim installation.

1.8 WARRANTY

- A. Special Warranty on Finishes: Manufacturer's standard form in which manufacturer agrees to repair finish or replace sheet metal flashing and trim that shows evidence of deterioration of factory-applied finishes within specified warranty period.
 1. Exposed Panel Finish: Deterioration includes, but is not limited to, the following:
 - a. Color fading more than 5 Hunter units when tested according to ASTM D 2244.
 - b. Chalking in excess of a No. 8 rating when tested according to ASTM D 4214.
 - c. Cracking, checking, peeling, or failure of paint to adhere to bare metal.

2. Finish Warranty Period: 20 years from date of Substantial Completion.

PART 2 - PRODUCTS

2.1 SHEET METALS

- A. General: Protect mechanical and other finishes on exposed surfaces from damage by applying a strippable, temporary protective film before shipping.
- B. Copper Sheet: ASTM B 370, cold-rolled copper sheet, H00 or H01 temper.
 1. Non-Patinated Exposed Finish: Mill.
- C. Aluminum Sheet: ASTM B 209, alloy as standard with manufacturer for finish required, with temper as required to suit forming operations and performance required.
 1. Exposed Coil-Coated Finishes:
 - a. Two-Coat Fluoropolymer: AAMA 620. Fluoropolymer finish containing not less than 70 percent PVDF resin by weight in color coat. Prepare, pretreat, and apply coating to exposed metal surfaces to comply with coating and resin manufacturers' written instructions.
 2. Color: As selected by Architect from manufacturer's full range.
- D. Stainless-Steel Sheet: ASTM A 240/A 240M or ASTM A 666, Type 304, dead soft, fully annealed.
 1. Finish: 3 (coarse, polished directional satin).
 2. Surface: Smooth, flat.

2.2 UNDERLAYMENT MATERIALS

- A. Felt: ASTM D 226, Type II (No. 30), asphalt-saturated organic felt, nonperforated.
- B. Self-Adhering, High-Temperature Sheet: Minimum 30 to 40 mils thick, consisting of slip-resisting polyethylene-film top surface laminated to layer of butyl or SBS-modified asphalt adhesive, with release-paper backing; cold applied. Provide primer when recommended by underlayment manufacturer.
 1. Thermal Stability: ASTM D 1970; stable after testing at 240 deg F.
 2. Low-Temperature Flexibility: ASTM D 1970; passes after testing at minus 20 deg F.

2.3 MISCELLANEOUS MATERIALS

- A. General: Provide materials and types of fasteners, solder, welding rods, protective coatings, separators, sealants, and other miscellaneous items as required for complete sheet metal flashing and trim installation and recommended by manufacturer of primary sheet metal or manufactured item unless otherwise indicated.
- B. Fasteners: Wood screws, annular threaded nails, self-tapping screws, self-locking rivets and bolts, and other suitable fasteners designed to withstand design loads and recommended by manufacturer of primary sheet metal or manufactured item.

1. General: Blind fasteners or self-drilling screws, gasketed, with hex-washer head.
 - a. Exposed Fasteners: Heads matching color of sheet metal using plastic caps or factory-applied coating.
 - b. Blind Fasteners: High-strength aluminum or stainless-steel rivets suitable for metal being fastened.
 - c. Spikes and Ferrules: Same material as gutter; with spike with ferrule matching internal gutter width.
 2. Fasteners for Aluminum Sheet: Aluminum or Series 300 stainless steel.
 3. Fasteners for Stainless-Steel Sheet: Series 300 stainless steel.
- C. Solder:
1. For Copper: ASTM B 32, Grade Sn50, 50 percent tin and 50 percent lead.
 2. For Stainless Steel: ASTM B 32, Grade Sn60, with an acid flux of type recommended by stainless-steel sheet manufacturer.
- D. Sealant Tape: Pressure-sensitive, 100 percent solids, gray polyisobutylene compound sealant tape with release-paper backing. Provide permanently elastic, nonsag, nontoxic, nonstaining tape 1/2 inch wide and 1/8 inch thick.
- E. Elastomeric Sealant: ASTM C 920, elastomeric silicone polymer sealant; low modulus; of type, grade, class, and use classifications required to seal joints in sheet metal flashing and trim and remain watertight.
- F. Butyl Sealant: ASTM C 1311, single-component, solvent-release butyl rubber sealant; polyisobutylene plasticized; heavy bodied for hooked-type expansion joints with limited movement.
- G. Epoxy Seam Sealer: Two-part, noncorrosive, aluminum seam-cementing compound, recommended by aluminum manufacturer for exterior nonmoving joints, including riveted joints.
- H. Bituminous Coating: Cold-applied asphalt emulsion complying with ASTM D 1187.
- I. Asphalt Roofing Cement: ASTM D 4586, asbestos free, of consistency required for application.

2.4 MANUFACTURED SHEET METAL FLASHING AND TRIM

- A. Reglets: Units of type, material, and profile indicated, formed to provide secure interlocking of separate reglet and counterflashing pieces, and compatible with flashing indicated with factory-mitered and -welded corners and junctions with interlocking counterflashing on exterior face, of same metal as reglet.
1. Manufacturers: Subject to compliance with requirements, provide products by one of the following:
 - a. Cheney Flashing Company.
 - b. Fry Reglet Corporation.
 - c. Heckmann Building Products Inc.
 - d. Hickman, W. P. Company.
 - e. Hohmann & Barnard, Inc.
 - f. Keystone Flashing Company, Inc.
 - g. Sandell Manufacturing Company, Inc.
 2. Material: Stainless steel, 0.019 inch thick.

3. Surface-Mounted Type: Provide with slotted holes for fastening to substrate, with neoprene or other suitable weatherproofing washers, and with channel for sealant at top edge.
4. Concrete Type: Provide temporary closure tape to keep reglet free of concrete materials, special fasteners for attaching reglet to concrete forms, and guides to ensure alignment of reglet section ends.
5. Masonry Type: Provide with offset top flange for embedment in masonry mortar joint.
6. Accessories:
 - a. Flexible-Flashing Retainer: Provide resilient plastic or rubber accessory to secure flexible flashing in reglet where clearance does not permit use of standard metal counterflashing or where Drawings show reglet without metal counterflashing.
 - b. Counterflashing Wind-Restraint Clips: Provide clips to be installed before counterflashing to prevent wind uplift of counterflashing lower edge.
7. Finish: Mill.

2.5 FABRICATION, GENERAL

- A. General: Custom fabricate sheet metal flashing and trim to comply with recommendations in SMACNA's "Architectural Sheet Metal Manual" that apply to design, dimensions, geometry, metal thickness, and other characteristics of item indicated. Fabricate items at the shop to greatest extent possible.
 1. Fabricate sheet metal flashing and trim in thickness or weight needed to comply with performance requirements, but not less than that specified for each application and metal.
 2. Obtain field measurements for accurate fit before shop fabrication.
 3. Form sheet metal flashing and trim without excessive oil canning, buckling, and tool marks and true to line and levels indicated, with exposed edges folded back to form hems.
 4. Conceal fasteners and expansion provisions where possible. Exposed fasteners are not allowed on faces exposed to view.
- B. Fabrication Tolerances: Fabricate sheet metal flashing and trim that is capable of installation to a tolerance of 1/4 inch in 20 feet on slope and location lines as indicated and within 1/8-inch offset of adjoining faces and of alignment of matching profiles.
- C. Sealed Joints: Form nonexpansion but movable joints in metal to accommodate elastomeric sealant.
- D. Expansion Provisions: Where lapped expansion provisions cannot be used, form expansion joints of intermeshing hooked flanges, not less than 1 inch deep, filled with butyl sealant concealed within joints.
- E. Fabricate cleats and attachment devices from same material as accessory being anchored or from compatible, noncorrosive metal.
- F. Fabricate cleats and attachment devices of sizes as recommended by SMACNA's "Architectural Sheet Metal Manual" for application, but not less than thickness of metal being secured.
- G. Seams: Fabricate nonmoving seams with flat-lock seams. Tin edges to be seamed, form seams, and solder.
- H. Do not use graphite pencils to mark metal surfaces.

2.6 LOW-SLOPE ROOF SHEET METAL FABRICATIONS

- A. Counterflashing: Fabricate from the following materials:

SHEET METAL FLASHING AND TRIM

1. Stainless Steel: 0.019 inch thick.

B. Flashing Receivers: Fabricate from the following materials:

1. Stainless Steel: 0.019 inch thick.

2.7 STEEP-SLOPE ROOF SHEET METAL FABRICATIONS

A. Drip Edges: Fabricate from the following materials:

1. Aluminum: 0.032 inch thick.

2.8 WALL SHEET METAL FABRICATIONS

A. Through-Wall Flashing Drip Edge: Fabricate continuous flashings in minimum 96-inch- long, but not exceeding 12-foot- long, sections, Fabricate from the following materials:

1. Stainless Steel: 0.016 inch thick.

2.9 MISCELLANEOUS SHEET METAL FABRICATIONS

A. Equipment Support Flashing: Fabricate from the following materials:

1. Galvanized Steel: [0.028 inch] <Insert thickness> thick.

B. Overhead-Piping Safety Pans: Fabricate from the following materials:

1. Galvanized Steel: 0.040 inch thick.

PART 3 - EXECUTION

3.1 EXAMINATION

A. Examine substrates, areas, and conditions, with Installer present, to verify actual locations, dimensions and other conditions affecting performance of the Work.

1. Verify compliance with requirements for installation tolerances of substrates.
2. Verify that substrate is sound, dry, smooth, clean, sloped for drainage, and securely anchored.

B. Proceed with installation only after unsatisfactory conditions have been corrected.

3.2 UNDERLAYMENT INSTALLATION

A. General: Install underlayment as indicated on Drawings.

B. Felt Underlayment: Install felt underlayment with adhesive for temporary anchorage to minimize use of mechanical fasteners under sheet metal flashing and trim. Apply in shingle fashion to shed water, with lapped joints of not less than 2 inches.

- C. Self-Adhering Sheet Underlayment: Install self-adhering sheet underlayment, wrinkle free. Apply primer if required by underlayment manufacturer. Comply with temperature restrictions of underlayment manufacturer for installation; use primer rather than nails for installing underlayment at low temperatures. Apply in shingle fashion to shed water, with end laps of not less than 6 inches staggered 24 inches between courses. Overlap side edges not less than 3-1/2 inches. Roll laps with roller. Cover underlayment within 14 days.

3.3 INSTALLATION, GENERAL

- A. General: Anchor sheet metal flashing and trim and other components of the Work securely in place, with provisions for thermal and structural movement. Use fasteners, solder, welding rods, protective coatings, separators, sealants, and other miscellaneous items as required to complete sheet metal flashing and trim system.
1. Install sheet metal flashing and trim true to line and levels indicated. Provide uniform, neat seams with minimum exposure of solder, welds, and sealant.
 2. Install sheet metal flashing and trim to fit substrates and to result in watertight performance. Verify shapes and dimensions of surfaces to be covered before fabricating sheet metal.
 3. Space cleats not more than 12 inches apart. Anchor each cleat with two fasteners. Bend tabs over fasteners.
 4. Install exposed sheet metal flashing and trim without excessive oil canning, buckling, and tool marks.
 5. Install sealant tape where indicated.
 6. Torch cutting of sheet metal flashing and trim is not permitted.
 7. Do not use graphite pencils to mark metal surfaces.
- B. Metal Protection: Where dissimilar metals will contact each other or corrosive substrates, protect against galvanic action by painting contact surfaces with bituminous coating or by other permanent separation as recommended by SMACNA.
1. Coat back side of stainless-steel sheet metal flashing and trim with bituminous coating where flashing and trim will contact wood, ferrous metal, or cementitious construction.
 2. Underlayment: Where installing metal flashing directly on cementitious or wood substrates, install a course of felt underlayment and cover with a slip sheet or install a course of polyethylene sheet.
- C. Expansion Provisions: Provide for thermal expansion of exposed flashing and trim. Space movement joints at a maximum of 10 feet with no joints allowed within 24 inches of corner or intersection. Where lapped expansion provisions cannot be used or would not be sufficiently watertight, form expansion joints of intermeshing hooked flanges, not less than 1 inch deep, filled with sealant concealed within joints.
- D. Seal joints as shown and as required for watertight construction.
1. Where sealant-filled joints are used, embed hooked flanges of joint members not less than 1 inch into sealant. Form joints to completely conceal sealant. When ambient temperature at time of installation is moderate, between 40 and 70 deg F, set joint members for 50 percent movement each way. Adjust setting proportionately for installation at higher ambient temperatures. Do not install sealant-type joints at temperatures below 40 deg F.
 2. Prepare joints and apply sealants to comply with requirements in Division 07 Section "Joint Sealants."
- E. Soldered Joints: Clean surfaces to be soldered, removing oils and foreign matter. Pre-tin edges of sheets to be soldered to a width of 1-1/2 inches, except reduce pre-tinning where pre-tinned surface would show in completed Work.

1. Do not use torches for soldering. Heat surfaces to receive solder and flow solder into joint. Fill joint completely. Completely remove flux and spatter from exposed surfaces.
2. Stainless-Steel Soldering: Tin edges of uncoated sheets using solder recommended for stainless steel and acid flux. Promptly remove acid flux residue from metal after tinning and soldering. Comply with solder manufacturer's recommended methods for cleaning and neutralization.
3. Copper Soldering: Tin edges of uncoated copper sheets using solder for copper.

3.4 ROOF DRAINAGE SYSTEM INSTALLATION

- A. General: Install sheet metal roof drainage items to produce complete roof drainage system according to SMACNA recommendations and as indicated. Coordinate installation of roof perimeter flashing with installation of roof drainage system.
- B. Expansion-Joint Covers: Install expansion-joint covers at locations and of configuration indicated. Lap joints a minimum of 4 inches in direction of water flow.

3.5 ROOF FLASHING INSTALLATION

- A. Counterflashing: Coordinate installation of counterflashing with installation of base flashing. Insert counterflashing in reglets or receivers and fit tightly to base flashing. Extend counterflashing 4 inches over base flashing. Lap counterflashing joints a minimum of 4 inches and bed with sealant. Secure in a waterproof manner by means of snap-in installation and sealant or lead wedges and sealant .
- B. Roof-Penetration Flashing: Coordinate installation of roof-penetration flashing with installation of roofing and other items penetrating roof. Seal with elastomeric sealant and clamp flashing to pipes that penetrate roof.

3.6 WALL FLASHING INSTALLATION

- A. General: Install sheet metal wall flashing to intercept and exclude penetrating moisture according to SMACNA recommendations and as indicated. Coordinate installation of wall flashing with installation of wall-opening components such as windows, doors, and louvers.
- B. Through-Wall Flashing: Installation of through-wall flashing is specified in Division 04 Section "Unit Masonry."
- C. Reglets: Installation of reglets is specified in Division 04 Section "Unit Masonry."

3.7 MISCELLANEOUS FLASHING INSTALLATION

- A. Equipment Support Flashing: Coordinate installation of equipment support flashing with installation of roofing and equipment. Weld or seal flashing with elastomeric sealant to equipment support member.

3.8 ERECTION TOLERANCES

- A. Installation Tolerances: Shim and align sheet metal flashing and trim within installed tolerance of 1/4 inch in 20 feet on slope and location lines as indicated and within 1/8-inch offset of adjoining faces and of alignment of matching profiles.

3.9 CLEANING AND PROTECTION

- A. Clean exposed metal surfaces of substances that interfere with uniform oxidation and weathering.
- B. Clean and neutralize flux materials. Clean off excess solder.
- C. Clean off excess sealants.
- D. Remove temporary protective coverings and strippable films as sheet metal flashing and trim are installed unless otherwise indicated in manufacturer's written installation instructions. On completion of installation, remove unused materials and clean finished surfaces. Maintain in a clean condition during construction.
- E. Replace sheet metal flashing and trim that have been damaged or that have deteriorated beyond successful repair by finish touchup or similar minor repair procedures.

END OF SECTION 076200

SECTION 078413 - PENETRATION FIRESTOPPING

PART 1 - GENERAL

1.1 RELATED DOCUMENTS

- A. Drawings and general provisions of the Contract, including General and Supplementary Conditions and Division 01 Specification Sections, apply to this Section.

1.2 SUMMARY

- A. Section Includes:
 - 1. Penetrations in fire-resistance-rated walls.

1.3 SUBMITTALS

- A. Product Data: For each type of product indicated.
- B. Product Schedule: For each penetration firestopping system. Include location and design designation of qualified testing and inspecting agency.
- C. Qualification Data: For qualified Installer.
- D. Installer Certificates: From Installer indicating penetration firestopping has been installed in compliance with requirements and manufacturer's written recommendations.
- E. Product Test Reports: Based on evaluation of comprehensive tests performed by a qualified testing agency, for penetration firestopping.

1.4 QUALITY ASSURANCE

- A. Installer Qualifications: A firm experienced in installing penetration firestopping similar in material, design, and extent to that indicated for this Project, whose work has resulted in construction with a record of successful performance. Qualifications include having the necessary experience, staff, and training to install manufacturer's products per specified requirements. Manufacturer's willingness to sell its penetration firestopping products to Contractor or to Installer engaged by Contractor does not in itself confer qualification on buyer.
- B. Fire-Test-Response Characteristics: Penetration firestopping shall comply with the following requirements:
 - 1. Penetration firestopping tests are performed by a qualified testing agency acceptable to authorities having jurisdiction.
 - 2. Penetration firestopping is identical to those tested per testing standard referenced in "Penetration Firestopping" Article. Provide rated systems complying with the following requirements:
 - a. Penetration firestopping products bear classification marking of qualified testing and inspecting agency.
 - b. Classification markings on penetration firestopping correspond to designations listed by the following:

1.5 PROJECT CONDITIONS

- A. Environmental Limitations: Do not install penetration firestopping when ambient or substrate temperatures are outside limits permitted by penetration firestopping manufacturers or when substrates are wet because of rain, frost, condensation, or other causes.
- B. Install and cure penetration firestopping per manufacturer's written instructions using natural means of ventilations or, where this is inadequate, forced-air circulation.

1.6 COORDINATION

- A. Coordinate construction of openings and penetrating items to ensure that penetration firestopping is installed according to specified requirements.
- B. Coordinate sizing of sleeves, openings, core-drilled holes, or cut openings to accommodate penetration firestopping.

PART 2 - PRODUCTS

2.1 MANUFACTURERS

- A. Manufacturers: Subject to compliance with requirements, [provide products by one of the following] [available manufacturers offering products that may be incorporated into the Work include, but are not limited to, the following]:
 - 1. Grace Construction Products.
 - 2. Hilti, Inc.
 - 3. Johns Manville.
 - 4. 3M Fire Protection Products.
 - 5. Tremco, Inc.; Tremco Fire Protection Systems Group.
 - 6. USG Corporation.

2.2 PENETRATION FIRESTOPPING

- A. Provide penetration firestopping that is produced and installed to resist spread of fire according to requirements indicated, resist passage of smoke and other gases, and maintain original fire-resistance rating of construction penetrated. Penetration firestopping systems shall be compatible with one another, with the substrates forming openings, and with penetrating items if any.
- B. Penetrations in Fire-Resistance-Rated Walls: Provide penetration firestopping with ratings determined per ASTM E 814 or UL 1479, based on testing at a positive pressure differential of 0.01-inch wg .
 - 1. Fire-resistance-rated walls include fire walls smoke-barrier walls.
 - 2. F-Rating: Not less than the fire-resistance rating of constructions penetrated.
- C. Penetrations in Horizontal Assemblies: Provide penetration firestopping with ratings determined per ASTM E 814 or UL 1479, based on testing at a positive pressure differential of 0.01-inch wg .
 - 1. Horizontal assemblies include floor/ceiling assemblies and ceiling membranes of roof/ceiling assemblies.
 - 2. F-Rating: At least 1 hour, but not less than the fire-resistance rating of constructions penetrated.

3. T-Rating: At least 1 hour, but not less than the fire-resistance rating of constructions penetrated except for floor penetrations within the cavity of a wall.
- D. Accessories: Provide components for each penetration firestopping system that are needed to install fill materials and to maintain ratings required. Use only those components specified by penetration firestopping manufacturer and approved by qualified testing and inspecting agency for firestopping indicated.
1. Permanent forming/damming/backing materials, including the following:
 - a. Slag-wool-fiber or rock-wool-fiber insulation.
 2. Substrate primers.
 3. Collars.
 4. Steel sleeves.

2.3 FILL MATERIALS

- A. Cast-in-Place Firestop Devices: Factory-assembled devices for use in cast-in-place concrete floors and consisting of an outer metallic sleeve lined with an intumescent strip, a radial extended flange attached to one end of the sleeve for fastening to concrete formwork, and a neoprene gasket.
- B. Latex Sealants: Single-component latex formulations that do not re-emulsify after cure during exposure to moisture.
- C. Firestop Devices: Factory-assembled collars formed from galvanized steel and lined with intumescent material sized to fit specific diameter of penetrant.
- D. Intumescent Composite Sheets: Rigid panels consisting of aluminum-foil-faced elastomeric sheet bonded to galvanized-steel sheet.
- E. Intumescent Putties: Nonhardening dielectric, water-resistant putties containing no solvents, inorganic fibers, or silicone compounds.
- F. Intumescent Wrap Strips: Single-component intumescent elastomeric sheets with aluminum foil on one side.
- G. Mortars: Prepackaged dry mixes consisting of a blend of inorganic binders, hydraulic cement, fillers, and lightweight aggregate formulated for mixing with water at Project site to form a nonshrinking, homogeneous mortar.
- H. Pillows/Bags: Reusable heat-expanding pillows/bags consisting of glass-fiber cloth cases filled with a combination of mineral-fiber, water-insoluble expansion agents, and fire-retardant additives. Where exposed, cover openings with steel-reinforcing wire mesh to protect pillows/bags from being easily removed.
- I. Silicone Foams: Multicomponent, silicone-based liquid elastomers that, when mixed, expand and cure in place to produce a flexible, nonshrinking foam.
- J. Silicone Sealants: Single-component, silicone-based, neutral-curing elastomeric sealants of grade indicated below:

2.4 MIXING

- A. For those products requiring mixing before application, comply with penetration firestopping manufacturer's written instructions for accurate proportioning of materials, water (if required), type of mixing equipment, selection of mixer speeds, mixing containers, mixing time, and other items or procedures needed to produce products of uniform quality with optimum performance characteristics for application indicated.

PART 3 - EXECUTION

3.1 EXAMINATION

- A. Examine substrates and conditions, with Installer present, for compliance with requirements for opening configurations, penetrating items, substrates, and other conditions affecting performance of the Work.
- B. Proceed with installation only after unsatisfactory conditions have been corrected.

3.2 PREPARATION

- A. Surface Cleaning: Clean out openings immediately before installing penetration firestopping to comply with manufacturer's written instructions and with the following requirements:
 - 1. Remove from surfaces of opening substrates and from penetrating items foreign materials that could interfere with adhesion of penetration firestopping.
 - 2. Clean opening substrates and penetrating items to produce clean, sound surfaces capable of developing optimum bond with penetration firestopping. Remove loose particles remaining from cleaning operation.
 - 3. Remove laitance and form-release agents from concrete.
- B. Priming: Prime substrates where recommended in writing by manufacturer using that manufacturer's recommended products and methods. Confine primers to areas of bond; do not allow spillage and migration onto exposed surfaces.
- C. Masking Tape: Use masking tape to prevent penetration firestopping from contacting adjoining surfaces that will remain exposed on completion of the Work and that would otherwise be permanently stained or damaged by such contact or by cleaning methods used to remove stains. Remove tape as soon as possible without disturbing firestopping's seal with substrates.

3.3 INSTALLATION

- A. General: Install penetration firestopping to comply with manufacturer's written installation instructions and published drawings for products and applications indicated.
- B. Install forming materials and other accessories of types required to support fill materials during their application and in the position needed to produce cross-sectional shapes and depths required to achieve fire ratings indicated.
 - 1. After installing fill materials and allowing them to fully cure, remove combustible forming materials and other accessories not indicated as permanent components of firestopping.
- C. Install fill materials for firestopping by proven techniques to produce the following results:

1. Fill voids and cavities formed by openings, forming materials, accessories, and penetrating items as required to achieve fire-resistance ratings indicated.
2. Apply materials so they contact and adhere to substrates formed by openings and penetrating items.
3. For fill materials that will remain exposed after completing the Work, finish to produce smooth, uniform surfaces that are flush with adjoining finishes.

3.4 IDENTIFICATION

- A. Identify penetration firestopping with preprinted metal or plastic labels. Attach labels permanently to surfaces adjacent to and within 6 inches of firestopping edge so labels will be visible to anyone seeking to remove penetrating items or firestopping. Use mechanical fasteners or self-adhering-type labels with adhesives capable of permanently bonding labels to surfaces on which labels are placed. Include the following information on labels:
 1. The words "Warning - Penetration Firestopping - Do Not Disturb. Notify Building Management of Any Damage."
 2. Contractor's name, address, and phone number.
 3. Designation of applicable testing and inspecting agency.
 4. Date of installation.
 5. Manufacturer's name.
 6. Installer's name.

3.5 FIELD QUALITY CONTROL

- A. Owner will engage a qualified testing agency to perform tests and inspections.
- B. Where deficiencies are found or penetration firestopping is damaged or removed because of testing, repair or replace penetration firestopping to comply with requirements.
- C. Proceed with enclosing penetration firestopping with other construction only after inspection reports are issued and installations comply with requirements.

3.6 CLEANING AND PROTECTION

- A. Clean off excess fill materials adjacent to openings as the Work progresses by methods and with cleaning materials that are approved in writing by penetration firestopping manufacturers and that do not damage materials in which openings occur.
- B. Provide final protection and maintain conditions during and after installation that ensure that penetration firestopping is without damage or deterioration at time of Substantial Completion. If, despite such protection, damage or deterioration occurs, immediately cut out and remove damaged or deteriorated penetration firestopping and install new materials to produce systems complying with specified requirements.

END OF SECTION 078413

SECTION 078446 - FIRE-RESISTIVE JOINT SYSTEMS

PART 1 - GENERAL

1.1 RELATED DOCUMENTS

- A. Drawings and general provisions of the Contract, including General and Supplementary Conditions and Division 01 Specification Sections, apply to this Section.

1.2 ACTION SUBMITTALS

- A. Product Schedule: For each fire-resistive joint system. Include location and design designation of qualified testing agency.
 - 1. Where Project conditions require modification to a qualified testing agency's illustration for a particular fire-resistive joint system condition, submit illustration, with modifications marked, approved by fire-resistive joint system manufacturer's fire-protection engineer as an engineering judgment or equivalent fire-resistance-rated assembly.

1.3 INFORMATIONAL SUBMITTALS

- A. Qualification Data: For qualified Installer.
- B. Installer Certificates: From Installer indicating fire-resistive joint systems have been installed in compliance with requirements and manufacturer's written recommendations.

1.4 QUALITY ASSURANCE

- A. Installer Qualifications: A firm that has been approved by FM Global according to FM Global 4991, "Approval of Firestop Contractors," or been evaluated by UL and found to comply with UL's "Qualified Firestop Contractor Program Requirements."
- B. Installer Qualifications: A firm experienced in installing fire-resistive joint systems similar in material, design, and extent to that indicated for this Project, whose work has resulted in construction with a record of successful performance. Qualifications include having the necessary experience, staff, and training to install manufacturer's products per specified requirements. Manufacturer's willingness to sell its fire-resistive joint system products to Contractor or to Installer engaged by Contractor does not in itself confer qualification on buyer.
- C. Fire-Test-Response Characteristics: Fire-resistive joint systems shall comply with the following requirements:
 - 1. Fire-resistive joint system tests are performed by a qualified testing agency acceptable to authorities having jurisdiction.
 - 2. Fire-resistive joint systems are identical to those tested per testing standard referenced in "Fire-Resistive Joint Systems" Article. Provide rated systems complying with the following requirements:
 - a. Fire-resistive joint system products bear classification marking of qualified testing agency.
 - b. Fire-resistive joint systems correspond to those indicated by reference to designations listed by the following:

- 1) UL in its "Fire Resistance Directory."

1.5 PROJECT CONDITIONS

- A. Environmental Limitations: Do not install fire-resistive joint systems when ambient or substrate temperatures are outside limits permitted by fire-resistive joint system manufacturers or when substrates are wet due to rain, frost, condensation, or other causes.
- B. Install and cure fire-resistive joint systems per manufacturer's written instructions using natural means of ventilation or, where this is inadequate, forced-air circulation.

1.6 COORDINATION

- A. Coordinate construction of joints to ensure that fire-resistive joint systems are installed according to specified requirements.
- B. Coordinate sizing of joints to accommodate fire-resistive joint systems.
- C. Notify Owner's testing agency at least seven days in advance of fire-resistive joint system installations; confirm dates and times on day preceding each series of installations.

PART 2 - PRODUCTS

2.1 FIRE-RESISTIVE JOINT SYSTEMS

- A. Where required, provide fire-resistive joint systems that are produced and installed to resist spread of fire according to requirements indicated, resist passage of smoke and other gases, and maintain original fire-resistance rating of assemblies in or between which fire-resistive joint systems are installed. Fire-resistive joint systems shall accommodate building movements without impairing their ability to resist the passage of fire and hot gases.
- B. Joints in or between Fire-Resistance-Rated Construction: Provide fire-resistive joint systems with ratings determined per ASTM E 1966 or UL 2079:
 1. Fire-Resistance Rating: Equal to or exceeding the fire-resistance rating of construction they will join.
 2. Manufacturers: Subject to compliance with requirements, provide products by one of the following:
 - a. Hilti, Inc.
 - b. Johns Manville.
 - c. Specified Technologies Inc.
 - d. 3M Fire Protection Products.
 - e. Tremco, Inc.; Tremco Fire Protection Systems Group.
 - f. USG Corporation.
- C. Exposed Fire-Resistive Joint Systems: Provide products with flame-spread and smoke-developed indexes of less than 25 and 450, respectively, as determined per ASTM E 84.
- D. Accessories: Provide components of fire-resistive joint systems, including primers and forming materials, that are needed to install fill materials and to maintain ratings required. Use only components specified by fire-resistive joint system manufacturer and approved by the qualified testing agency for systems indicated.

PART 3 - EXECUTION

3.1 EXAMINATION

- A. Examine substrates and conditions, with Installer present, for compliance with requirements for joint configurations, substrates, and other conditions affecting performance of the Work.
- B. Proceed with installation only after unsatisfactory conditions have been corrected.

3.2 PREPARATION

- A. Surface Cleaning: Clean joints immediately before installing fire-resistive joint systems to comply with fire-resistive joint system manufacturer's written instructions and the following requirements:
 - 1. Remove from surfaces of joint substrates foreign materials that could interfere with adhesion of fill materials.
 - 2. Clean joint substrates to produce clean, sound surfaces capable of developing optimum bond with fill materials. Remove loose particles remaining from cleaning operation.
 - 3. Remove laitance and form-release agents from concrete.
- B. Priming: Prime substrates where recommended in writing by fire-resistive joint system manufacturer using that manufacturer's recommended products and methods. Confine primers to areas of bond; do not allow spillage and migration onto exposed surfaces.
- C. Masking Tape: Use masking tape to prevent fill materials of fire-resistive joint system from contacting adjoining surfaces that will remain exposed on completion of the Work and that would otherwise be permanently stained or damaged by such contact or by cleaning methods used to remove stains. Remove tape as soon as possible without disturbing fire-resistive joint system's seal with substrates.

3.3 INSTALLATION

- A. General: Install fire-resistive joint systems to comply with manufacturer's written installation instructions and published drawings for products and applications indicated.
- B. Install forming materials and other accessories of types required to support fill materials during their application and in position needed to produce cross-sectional shapes and depths required to achieve fire ratings indicated.
 - 1. After installing fill materials and allowing them to fully cure, remove combustible forming materials and other accessories not indicated as permanent components of fire-resistive joint system.
- C. Install fill materials for fire-resistive joint systems by proven techniques to produce the following results:
 - 1. Fill voids and cavities formed by joints and forming materials as required to achieve fire-resistance ratings indicated.
 - 2. Apply fill materials so they contact and adhere to substrates formed by joints.
 - 3. For fill materials that will remain exposed after completing the Work, finish to produce smooth, uniform surfaces that are flush with adjoining finishes.

3.4 IDENTIFICATION

- A. Identify fire-resistive joint systems with preprinted metal or plastic labels. Attach labels permanently to surfaces adjacent to and within 6 inches of joint edge so labels will be visible to anyone seeking to remove or penetrate joint system. Use mechanical fasteners or self-adhering-type labels with adhesives capable of permanently bonding labels to surfaces on which labels are placed. Include the following information on labels:
1. The words "Warning - Fire-Resistive Joint System - Do Not Disturb. Notify Building Management of Any Damage."
 2. Contractor's name, address, and phone number.
 3. Designation of applicable testing agency.
 4. Date of installation.
 5. Manufacturer's name.
 6. Installer's name.

3.5 FIELD QUALITY CONTROL

- A. Where deficiencies are found or fire-resistive joint systems are damaged or removed due to testing, repair or replace fire-resistive joint systems so they comply with requirements.
- B. Proceed with enclosing fire-resistive joint systems with other construction only after inspection reports are issued and installations comply with requirements.

3.6 CLEANING AND PROTECTING

- A. Clean off excess fill materials adjacent to joints as the Work progresses by methods and with cleaning materials that are approved in writing by fire-resistive joint system manufacturers and that do not damage materials in which joints occur.
- B. Provide final protection and maintain conditions during and after installation that ensure fire-resistive joint systems are without damage or deterioration at time of Substantial Completion. If damage or deterioration occurs despite such protection, cut out and remove damaged or deteriorated fire-resistive joint systems immediately and install new materials to produce fire-resistive joint systems complying with specified requirements.

END OF SECTION 078446

SECTION 079200 - JOINT SEALANTS

PART 1 - GENERAL

1.1 RELATED DOCUMENTS

- A. Drawings and general provisions of the Contract, including General and Supplementary Conditions and Division 01 Specification Sections, apply to this Section.

1.2 SUMMARY

- A. Section Includes:

1. Silicone joint sealants.
2. Urethane joint sealants.
3. Latex joint sealants.
4. Acoustical joint sealants.

- B. Related Sections:

1. Division 04 Section "Unit Masonry" for masonry control and expansion joint fillers and gaskets.
2. Division 07 Section "Fire-Resistive Joint Systems" for sealing joints in fire-resistance-rated construction.
3. Division 08 Section "Glazing" for glazing sealants.
4. Division 09 Section "Gypsum Board" for sealing perimeter joints.

1.3 |PRECONSTRUCTION TESTING

- A. Preconstruction Compatibility and Adhesion Testing: Submit to joint-sealant manufacturers, for testing indicated below, samples of materials that will contact or affect joint sealants.
 1. Use ASTM C 1087 to determine whether priming and other specific joint preparation techniques are required to obtain rapid, optimum adhesion of joint sealants to joint substrates.
 2. Testing will not be required if joint-sealant manufacturers submit joint preparation data that are based on previous testing, not older than 24 months, of sealant products for adhesion to, and compatibility with, joint substrates and other materials matching those submitted.

1.4 SUBMITTALS

- A. Product Data: For each joint-sealant product indicated.
- B. Joint-Sealant Schedule: Include the following information:
 1. Joint-sealant application, joint location, and designation.
 2. Joint-sealant manufacturer and product name.
 3. Joint-sealant formulation.
 4. Joint-sealant color.
- C. Qualification Data: For qualified Installer.

- D. Product Certificates: For each kind of joint sealant and accessory, from manufacturer.
- E. Preconstruction Compatibility and Adhesion Test Reports: From sealant manufacturer, indicating the following:
 - 1. Materials forming joint substrates and joint-sealant backings have been tested for compatibility and adhesion with joint sealants.
 - 2. Interpretation of test results and written recommendations for primers and substrate preparation needed for adhesion.

1.5 QUALITY ASSURANCE

- A. Installer Qualifications: Manufacturer's authorized representative who is trained and approved for installation of units required for this Project.
- B. Source Limitations: Obtain each kind of joint sealant from single source from single manufacturer.

1.6 PROJECT CONDITIONS

- A. Do not proceed with installation of joint sealants under the following conditions:
 - 1. When ambient and substrate temperature conditions are outside limits permitted by joint-sealant manufacturer or are below 40 deg F .
 - 2. When joint substrates are wet.
 - 3. Where joint widths are less than those allowed by joint-sealant manufacturer for applications indicated.
 - 4. Where contaminants capable of interfering with adhesion have not yet been removed from joint substrates.

1.7 WARRANTY

- A. Special Installer's Warranty: Manufacturer's standard form in which Installer agrees to repair or replace joint sealants that do not comply with performance and other requirements specified in this Section within specified warranty period.
 - 1. Warranty Period: Two years from date of Substantial Completion.
- B. Special Manufacturer's Warranty: Manufacturer's standard form in which joint-sealant manufacturer agrees to furnish joint sealants to repair or replace those that do not comply with performance and other requirements specified in this Section within specified warranty period.
 - 1. Warranty Period: Five years from date of Substantial Completion.

PART 2 - PRODUCTS

2.1 MATERIALS, GENERAL

- A. Compatibility: Provide joint sealants, backings, and other related materials that are compatible with one another and with joint substrates under conditions of service and application, as demonstrated by joint-sealant manufacturer, based on testing and field experience.

- B. Liquid-Applied Joint Sealants: Comply with ASTM C 920 and other requirements indicated for each liquid-applied joint sealant specified, including those referencing ASTM C 920 classifications for type, grade, class, and uses related to exposure and joint substrates.
 - 1. Suitability for Immersion in Liquids. Where sealants are indicated for Use I for joints that will be continuously immersed in liquids, provide products that have undergone testing according to ASTM C 1247. Liquid used for testing sealants is deionized water, unless otherwise indicated.
- C. Stain-Test-Response Characteristics: Where sealants are specified to be nonstaining to porous substrates, provide products that have undergone testing according to ASTM C 1248 and have not stained porous joint substrates indicated for Project.
- D. Suitability for Contact with Food: Where sealants are indicated for joints that will come in repeated contact with food, provide products that comply with 21 CFR 177.2600.
- E. Colors of Exposed Joint Sealants: As selected by Architect from manufacturer's full range - For any sealants that will be visible in the finished project, the Architect shall make initial color selections from manufacturer's samples, the contractor shall obtain a small sample of each color selection and place a 12" long x 1/2" wide bead on a suitable substrate for the architect's final selection.

2.2 SILICONE JOINT SEALANTS

- A. Single-Component, Nonsag, Neutral-Curing Silicone Joint Sealant: ASTM C 920, Type S, Grade NS, Class 100/50, for Use NT.
 - 1. Products: Subject to compliance with requirements, provide one of the following:
 - a. Dow Corning Corporation; 790.
 - b. GE Advanced Materials - Silicones; SilPruf LM SCS2700.
 - c. Pecora Corporation; 301 NS.
 - d. Tremco Incorporated; Spectrem 1.
- B. Single-Component, Nonsag, Traffic-Grade, Neutral-Curing Silicone Joint Sealant: ASTM C 920, Type S, Grade NS, Class 100/50, for Use T.
 - 1. Products: Subject to compliance with requirements, provide one of the following:
 - a. Dow Corning Corporation; 790.
 - b. Pecora Corporation; 301 NS.
 - c. Tremco Incorporated; Spectrem 800.
- C. Mildew-Resistant, Single-Component, Nonsag, Neutral-Curing Silicone Joint Sealant: ASTM C 920, Type S, Grade NS, Class 25, for Use NT.
 - 1. Products: Subject to compliance with requirements, available products that may be incorporated into the Work include, but are not limited to, the following:
 - a. Pecora Corporation; 898.

2.3 URETHANE JOINT SEALANTS

- A. Single-Component, Nonsag, Urethane Joint Sealant: ASTM C 920, Type S, Grade NS, Class 25, for Use NT.

1. Products: Subject to compliance with requirements, available products that may be incorporated into the Work include, but are not limited to, the following:
 - a. BASF Building Systems; Sonolastic NP1.
 - b. Pecora Corporation; Dynatrol I-XL.
 - c. Sika Corporation, Construction Products Division; Sikaflex - 1a.
 - d. Tremco Incorporated; Vulkem 116.
 - B. Single-Component, Pourable, Traffic-Grade, Urethane Joint Sealant: ASTM C 920, Type S, Grade P, Class 25, for Use T.
 1. Products: Subject to compliance with requirements, available products that may be incorporated into the Work include, but are not limited to, the following:
 - a. BASF Building Systems; Sonolastic SL 1.
 - b. Pecora Corporation; Urexpan NR-201.
 - c. Sika Corporation. Construction Products Division; Sikaflex - 1CSL.
 - d. Tremco Incorporated; Vulkem 45.
- 2.4 LATEX JOINT SEALANTS
- A. Latex Joint Sealant: Acrylic latex or siliconized acrylic latex, ASTM C 834, Type OP, Grade NF.
 1. Products: Subject to compliance with requirements, available products that may be incorporated into the Work include, but are not limited to, the following:
 - a. BASF Building Systems; Sonolac.
 - b. Pecora Corporation; AC-20+.
 - c. Tremco Incorporated; Tremflex 834.
- 2.5 ACOUSTICAL JOINT SEALANTS
- A. Acoustical Joint Sealant: Manufacturer's standard nonsag, paintable, nonstaining latex sealant complying with ASTM C 834. Product effectively reduces airborne sound transmission through perimeter joints and openings in building construction as demonstrated by testing representative assemblies according to ASTM E 90.
 1. Products: Subject to compliance with requirements, [provide the following] [provide one of the following] [available products that may be incorporated into the Work include, but are not limited to, the following]:
 - a. Pecora Corporation; AC-20 FTR.
 - b. USG Corporation; SHEETROCK Acoustical Sealant.
- 2.6 JOINT SEALANT BACKING
- A. General: Provide sealant backings of material that are nonstaining; are compatible with joint substrates, sealants, primers, and other joint fillers; and are approved for applications indicated by sealant manufacturer based on field experience and laboratory testing.
 - B. Cylindrical Sealant Backings: ASTM C 1330, Type C (closed-cell material with a surface skin) Type O (open-cell material) Type B (bicellular material with a surface skin) or any of the preceding types, as approved in writing by joint-sealant manufacturer for joint application indicated, and of size and density to control sealant depth and otherwise contribute to producing optimum sealant performance.

2.7 MISCELLANEOUS MATERIALS

- A. Primer: Material recommended by joint-sealant manufacturer where required for adhesion of sealant to joint substrates indicated, as determined from preconstruction joint-sealant-substrate tests and field tests.
- B. Cleaners for Nonporous Surfaces: Chemical cleaners acceptable to manufacturers of sealants and sealant backing materials, free of oily residues or other substances capable of staining or harming joint substrates and adjacent nonporous surfaces in any way, and formulated to promote optimum adhesion of sealants to joint substrates.
- C. Masking Tape: Nonstaining, nonabsorbent material compatible with joint sealants and surfaces adjacent to joints.

PART 3 - EXECUTION

3.1 EXAMINATION

- A. Examine joints indicated to receive joint sealants, with Installer present, for compliance with requirements for joint configuration, installation tolerances, and other conditions affecting joint-sealant performance.
- B. Proceed with installation only after unsatisfactory conditions have been corrected.

3.2 PREPARATION

- A. Surface Cleaning of Joints: Clean out joints immediately before installing joint sealants to comply with joint-sealant manufacturer's written instructions and the following requirements:
 - 1. Remove all foreign material from joint substrates that could interfere with adhesion of joint sealant, including dust, paints (except for permanent, protective coatings tested and approved for sealant adhesion and compatibility by sealant manufacturer), old joint sealants, oil, grease, waterproofing, water repellents, water, surface dirt, and frost.
 - 2. Clean porous joint substrate surfaces by brushing, grinding, mechanical abrading, or a combination of these methods to produce a clean, sound substrate capable of developing optimum bond with joint sealants. Remove loose particles remaining after cleaning operations above by vacuuming or blowing out joints with oil-free compressed air. Porous joint substrates include the following:
 - a. Concrete.
 - b. Masonry.
 - c. Unglazed surfaces of ceramic tile.
 - 3. Remove laitance and form-release agents from concrete.
 - 4. Clean nonporous joint substrate surfaces with chemical cleaners or other means that do not stain, harm substrates, or leave residues capable of interfering with adhesion of joint sealants. Nonporous joint substrates include the following:
 - a. Metal.
 - b. Glass.
 - c. Glazed surfaces of ceramic tile.
- B. Joint Priming: Prime joint substrates where recommended by joint-sealant manufacturer or as indicated by preconstruction joint-sealant-substrate tests or prior experience. Apply primer to comply with joint-sealant manufacturer's written instructions. Confine primers to areas of joint-sealant bond; do not allow spillage or migration onto adjoining surfaces.

- C. Masking Tape: Use masking tape where required to prevent contact of sealant or primer with adjoining surfaces that otherwise would be permanently stained or damaged by such contact or by cleaning methods required to remove sealant smears. Remove tape immediately after tooling without disturbing joint seal.

3.3 INSTALLATION OF JOINT SEALANTS

- A. General: Comply with joint-sealant manufacturer's written installation instructions for products and applications indicated, unless more stringent requirements apply.
- B. Sealant Installation Standard: Comply with recommendations in ASTM C 1193 for use of joint sealants as applicable to materials, applications, and conditions indicated.
- C. Install sealant backings of kind indicated to support sealants during application and at position required to produce cross-sectional shapes and depths of installed sealants relative to joint widths that allow optimum sealant movement capability.
 - 1. Do not leave gaps between ends of sealant backings.
 - 2. Do not stretch, twist, puncture, or tear sealant backings.
 - 3. Remove absorbent sealant backings that have become wet before sealant application and replace them with dry materials.
- D. Install bond-breaker tape behind sealants where sealant backings are not used between sealants and backs of joints.
- E. Install sealants using proven techniques that comply with the following and at the same time backings are installed:
 - 1. Place sealants so they directly contact and fully wet joint substrates.
 - 2. Completely fill recesses in each joint configuration.
 - 3. Produce uniform, cross-sectional shapes and depths relative to joint widths that allow optimum sealant movement capability.
- F. Tooling of Nonsag Sealants: Immediately after sealant application and before skinning or curing begins, tool sealants according to requirements specified in subparagraphs below to form smooth, uniform beads of configuration indicated; to eliminate air pockets; and to ensure contact and adhesion of sealant with sides of joint.
 - 1. Remove excess sealant from surfaces adjacent to joints.
 - 2. Use tooling agents that are approved in writing by sealant manufacturer and that do not discolor sealants or adjacent surfaces.
 - 3. Provide concave joint profile per Figure 8A in ASTM C 1193, unless otherwise indicated.
 - 4. Provide flush joint profile where indicated per Figure 8B in ASTM C 1193.
 - 5. Provide recessed joint configuration of recess depth and at locations indicated per Figure 8C in ASTM C 1193.
 - a. Use masking tape to protect surfaces adjacent to recessed tooled joints.
- G. Installation of Preformed Silicone-Sealant System: Comply with the following requirements:
 - 1. Apply masking tape to each side of joint, outside of area to be covered by sealant system.
 - 2. Apply silicone sealant to each side of joint to produce a bead of size complying with preformed silicone-sealant system manufacturer's written instructions and covering a bonding area of not less than 3/8 inch. Hold edge of sealant bead 1/4 inch inside masking tape.
 - 3. Within 10 minutes of sealant application, press silicone extrusion into sealant to wet extrusion and substrate. Use a roller to apply consistent pressure and ensure uniform contact between sealant and both extrusion and substrate.

4. Complete installation of sealant system in horizontal joints before installing in vertical joints. Lap vertical joints over horizontal joints. At ends of joints, cut silicone extrusion with a razor knife.
- H. Installation of Preformed Foam Sealants: Install each length of sealant immediately after removing protective wrapping. Do not pull or stretch material. Produce seal continuity at ends, turns, and intersections of joints. For applications at low ambient temperatures, apply heat to sealant in compliance with sealant manufacturer's written instructions.
- I. Acoustical Sealant Installation: At sound-rated assemblies and elsewhere as indicated, seal construction at perimeters, behind control joints, and at openings and penetrations with a continuous bead of acoustical sealant. Install acoustical sealant at both faces of partitions at perimeters and through penetrations. Comply with ASTM C 919 and with manufacturer's written recommendations.

3.4 FIELD QUALITY CONTROL

- A. Field-Adhesion Testing: Field test joint-sealant adhesion to joint substrates as follows:
 1. Extent of Testing: Test completed and cured sealant joints as follows:
 - a. Perform 10 tests for the first 1000 feet of joint length for each kind of sealant and joint substrate.
 2. Test Method: Test joint sealants according to Method A, Field-Applied Sealant Joint Hand Pull Tab, in Appendix X1 in ASTM C 1193 or Method A, Tail Procedure, in ASTM C 1521.
 - a. For joints with dissimilar substrates, verify adhesion to each substrate separately; extend cut along one side, verifying adhesion to opposite side. Repeat procedure for opposite side.
 3. Record test results in a field-adhesion-test log. Include dates when sealants were installed, names of persons who installed sealants, test dates, test locations, whether joints were primed, adhesion results and percent elongations, sealant fill, sealant configuration, and sealant dimensions.
 4. Repair sealants pulled from test area by applying new sealants following same procedures used originally to seal joints. Ensure that original sealant surfaces are clean and that new sealant contacts original sealant.
- B. Evaluation of Field-Adhesion Test Results: Sealants not evidencing adhesive failure from testing or noncompliance with other indicated requirements will be considered satisfactory. Remove sealants that fail to adhere to joint substrates during testing or to comply with other requirements. Retest failed applications until test results prove sealants comply with indicated requirements.

3.5 CLEANING

- A. Clean off excess sealant or sealant smears adjacent to joints as the Work progresses by methods and with cleaning materials approved in writing by manufacturers of joint sealants and of products in which joints occur.

3.6 PROTECTION

- A. Protect joint sealants during and after curing period from contact with contaminating substances and from damage resulting from construction operations or other causes so sealants are without deterioration or damage at time of Substantial Completion. If, despite such protection, damage or deterioration occurs, cut out and remove damaged or deteriorated joint sealants immediately so installations with repaired areas are indistinguishable from original work.

3.7 JOINT-SEALANT SCHEDULE

- A. Joint-Sealant Application: Exterior joints in horizontal traffic surfaces.
 - 1. Joint Locations:
 - a. Isolation and contraction joints in cast-in-place concrete slabs.
 - 2. Silicone Joint Sealant: Single component, pourable, traffic grade, neutral curing.
- B. Joint-Sealant Application: Exterior joints in vertical surfaces and horizontal nontraffic surfaces.
 - 1. Joint Locations:
 - a. Control and expansion joints in unit masonry.
 - b. Perimeter joints between materials listed above and frames of doors windows and louvers.
 - c. Control and expansion joints in ceilings and other overhead surfaces.
 - d. Other joints as indicated.
 - 2. Silicone Joint Sealant: Single component, nonsag, neutral curing, Class 100/50.
- C. Joint-Sealant Application: Interior joints in horizontal traffic surfaces.
 - 1. Joint Locations:
 - a. Isolation joints in cast-in-place concrete slabs.
 - b. Control and expansion joints in tile flooring.
 - 2. Silicone Joint Sealant: Single component, nonsag, traffic grade, neutral curing.
- D. Joint-Sealant Application: Interior joints in vertical surfaces and horizontal nontraffic surfaces.
 - 1. Joint Locations:
 - a. Control and expansion joints on exposed interior surfaces of exterior walls.
 - b. Perimeter joints of exterior openings where indicated.
 - c. Vertical joints on exposed surfaces of interior unit masonry .
 - d. Perimeter joints between interior wall surfaces and frames of interior doors and windows.
 - 2. Joint Sealant: Latex.
 - 3. Joint-Sealant Color: As selected by Architect from manufacturer's full range of colors.
- E. Joint-Sealant Application: Mildew-resistant interior joints in vertical surfaces and horizontal nontraffic surfaces.
 - 1. Joint Sealant Location:

- a. Joints between plumbing fixtures and adjoining walls, floors, and counters.
 - b. Tile control and expansion joints where indicated.
 2. Joint Sealant: Mildew resistant, single component, nonsag, neutral curing, Silicone.
 3. Joint-Sealant Color: As selected by Architect from manufacturer's full range of colors.
- F. Joint-Sealant Application: Interior acoustical joints in vertical surfaces and horizontal nontraffic surfaces.
 1. Joint Location:
 - a. Acoustical joints where indicated.
 - b. Other joints as indicated.
 2. Joint Sealant: Acoustical.
 3. Joint-Sealant Color: As selected by Architect from manufacturer's full range.

END OF SECTION 079200

SECTION 081113 - HOLLOW METAL DOORS AND FRAMES

PART 1 - GENERAL

1.1 RELATED DOCUMENTS

- A. Drawings and general provisions of the Contract, including General and Supplementary Conditions and Division 01 Specification Sections, apply to this Section.

1.2 SUMMARY

- A. Section Includes:
 - 1. Standard hollow metal doors and frames.
 - 2. Custom hollow metal .

1.3 DEFINITIONS

- A. Minimum Thickness: Minimum thickness of base metal without coatings.
- B. Standard Hollow Metal Work: Hollow metal work fabricated according to ANSI/SDI A250.8.

1.4 SUBMITTALS

- A. Product Data: For each type of product indicated. Include construction details, material descriptions, core descriptions, fire-resistance rating, and finishes.
- B. Shop Drawings: Include the following:
 - 1. Elevations of each door design.
 - 2. Details of doors, including vertical and horizontal edge details and metal thicknesses.
 - 3. Frame details for each frame type, including dimensioned profiles and metal thicknesses.
 - 4. Details of each different wall opening condition.
 - 5. Details of accessories.
 - 6. Details of moldings, removable stops, and glazing.
- C. Other Action Submittals:
 - 1. Schedule: Provide a schedule of hollow metal work prepared by or under the supervision of supplier, using same reference numbers for details and openings as those on Drawings. Coordinate with door hardware schedule.
- D. Product Test Reports: Based on evaluation of comprehensive tests performed by a qualified testing agency, for each type of hollow metal door and frame assembly.

1.5 QUALITY ASSURANCE

- A. Source Limitations: Obtain hollow metal work from single source from single manufacturer.

- B. Fire-Rated Door Assemblies: Assemblies complying with NFPA 80 that are listed and labeled by a qualified testing agency, for fire-protection ratings indicated, based on testing at positive pressure according to UL 10C.
 - 1. Temperature-Rise Limit: At vertical exit enclosures and exit passageways, provide doors that have a maximum transmitted temperature end point of not more than 450 deg F above ambient after 30 minutes of standard fire-test exposure.
- C. Fire-Rated, Borrowed-Light Frame Assemblies: Assemblies complying with NFPA 80 that are listed and labeled, by a testing and inspecting agency acceptable to authorities having jurisdiction, for fire-protection ratings indicated, based on testing according to NFPA 257 or UL 9. Label each individual glazed lite.

1.6 DELIVERY, STORAGE, AND HANDLING

- A. Deliver hollow metal work palletized, wrapped, or crated to provide protection during transit and Project-site storage. Do not use nonvented plastic.
 - 1. Provide additional protection to prevent damage to finish of factory-finished units.
- B. Deliver welded frames with two removable spreader bars across bottom of frames, tack welded to jambs and mullions.
- C. Store hollow metal work under cover at Project site. Place in stacks of five units maximum in a vertical position with heads up, spaced by blocking, on minimum 4-inch- high wood blocking. Do not store in a manner that traps excess humidity.
 - 1. Provide minimum 1/4-inch space between each stacked door to permit air circulation.

1.7 PROJECT CONDITIONS

- A. Field Measurements: Verify actual dimensions of openings by field measurements before fabrication.

1.8 COORDINATION

- A. Coordinate installation of anchorages for hollow metal frames. Furnish setting drawings, templates, and directions for installing anchorages, including sleeves, concrete inserts, anchor bolts, and items with integral anchors. Deliver such items to Project site in time for installation.

PART 2 - PRODUCTS

2.1 MANUFACTURERS

- A. Manufacturers: Subject to compliance with requirements, available manufacturers offering products that may be incorporated into the Work include, but are not limited to, the following:
 - 1. Amweld Building Products, LLC.
 - 2. Ceco Door Products; an Assa Abloy Group company.
 - 3. Curries Company; an Assa Abloy Group company.
 - 4. Deansteel Manufacturing Company, Inc.
 - 5. Fleming Door Products Ltd.; an Assa Abloy Group company.
 - 6. Karpen Steel Custom Doors & Frames.

7. Kewanee Corporation (The).
8. Mesker Door Inc.
9. Pioneer Industries, Inc.
10. Steelcraft; an Ingersoll-Rand company.
11. Windsor Republic Doors.

2.2 MATERIALS

- A. Cold-Rolled Steel Sheet: ASTM A 1008/A 1008M, Commercial Steel (CS), Type B; suitable for exposed applications.
- B. Hot-Rolled Steel Sheet: ASTM A 1011/A 1011M, Commercial Steel (CS), Type B; free of scale, pitting, or surface defects; pickled and oiled.
- C. Metallic-Coated Steel Sheet: ASTM A 653/A 653M, Commercial Steel (CS), Type B; with minimum G60 or A60 metallic coating.
- D. Frame Anchors: ASTM A 591/A 591M, Commercial Steel (CS), 40Z coating designation; mill phosphatized.
 1. For anchors built into exterior walls, steel sheet complying with ASTM A 1008/A 1008M or ASTM A 1011/A 1011M, hot-dip galvanized according to ASTM A 153/A 153M, Class B.
- E. Inserts, Bolts, and Fasteners: Hot-dip galvanized according to ASTM A 153/A 153M.
- F. Powder-Actuated Fasteners in Concrete: Fastener system of type suitable for application indicated, fabricated from corrosion-resistant materials, with clips or other accessory devices for attaching hollow metal frames of type indicated.
- G. Grout: ASTM C 476, except with a maximum slump of 4 inches , as measured according to ASTM C 143/C 143M.
- H. Mineral-Fiber Insulation: ASTM C 665, Type I (blankets without membrane facing); consisting of fibers manufactured from slag or rock wool with 6- to 12-lb/cu. ft. density; with maximum flame-spread and smoke-development indexes of 25 and 50, respectively; passing ASTM E 136 for combustion characteristics.
- I. Glazing: Comply with requirements in Division 08 Section "Glazing."
- J. Bituminous Coating: Cold-applied asphalt mastic, SSPC-Paint 12, compounded for 15-mil dry film thickness per coat. Provide inert-type noncorrosive compound free of asbestos fibers, sulfur components, and other deleterious impurities.

2.3 STANDARD HOLLOW METAL DOORS

- A. General: Provide doors of design indicated, not less than thickness indicated; fabricated with smooth surfaces, without visible joints or seams on exposed faces unless otherwise indicated. Comply with ANSI/SDI A250.8.
 1. Design: Flush panel.
 2. Core Construction: Manufacturer's standard kraft-paper honeycomb, polystyrene, polyurethane, polyisocyanurate, mineral-board, or vertical steel-stiffener core.
 - a. Fire Door Core: As required to provide fire-protection and temperature-rise ratings indicated.

- b. Thermal-Rated (Insulated) Doors: Where indicated, provide doors fabricated with thermal-resistance value (R-value) of not less than 4.0 deg F x h x sq. ft./Btu when tested according to ASTM C 1363.
 - 1) Locations: Exterior doors.
 - 3. Vertical Edges for Single-Acting Doors: Beveled edge.
 - a. Beveled Edge: 1/8 inch in 2 inches .
 - 4. Vertical Edges for Double-Acting Doors: Round vertical edges with 2-1/8-inch radius.
 - 5. Top and Bottom Edges: Closed with flush or inverted 0.042-inch- thick, end closures or channels of same material as face sheets.
 - 6. Tolerances: Comply with SDI 117, "Manufacturing Tolerances for Standard Steel Doors and Frames."
- B. Exterior Doors: Face sheets fabricated from metallic-coated steel sheet. Provide doors complying with requirements indicated below by referencing ANSI/SDI A250.8 for level and model and ANSI/SDI A250.4 for physical performance level:
- 1. Level 3 and Physical Performance Level A (Extra Heavy Duty), Model 2 (Seamless).
- C. Interior Doors: Face sheets fabricated from cold-rolled steel sheet unless metallic-coated sheet is indicated. Provide doors complying with requirements indicated below by referencing ANSI/SDI A250.8 for level and model and ANSI/SDI A250.4 for physical performance level:
- 1. Level 3 and Physical Performance Level A (Extra Heavy Duty), Model 2 (Seamless).
- D. Hardware Reinforcement: Fabricate according to ANSI/SDI A250.6 with reinforcing plates from same material as door face sheets.
- E. Fabricate concealed stiffeners and hardware reinforcement from either cold- or hot-rolled steel sheet.
- 2.4 STANDARD HOLLOW METAL FRAMES
- A. General: Comply with ANSI/SDI A250.8 and with details indicated for type and profile.
- B. Exterior Frames: Fabricated from metallic-coated steel sheet.
- 1. Fabricate frames with mitered or coped corners.
 - 2. Fabricate frames as full profile welded unless otherwise indicated.
 - 3. Frames for Level 3 Steel Doors: 0.053-inch- thick steel sheet.
- C. Interior Frames: Fabricated from cold-rolled steel sheet unless metallic-coated sheet is indicated.
- 1. Fabricate frames with mitered or coped corners.
 - 2. Fabricate frames as full profile welded unless otherwise indicated.
 - 3. Fabricate knocked-down, drywall slip-on frames for in-place gypsum board partitions.
 - 4. Frames for Level 3 Steel Doors: 0.053-inch- thick steel sheet.
 - 5. Frames for Wood Doors: 0.053-inch- thick steel sheet.
 - 6. Frames for Borrowed Lights: Same as adjacent door frame.
- D. Hardware Reinforcement: Fabricate according to ANSI/SDI A250.6 with reinforcement plates from same material as frames.

2.5 FRAME ANCHORS

A. Jamb Anchors:

1. Masonry Type: Adjustable strap-and-stirrup or T-shaped anchors to suit frame size, not less than 0.042 inch thick, with corrugated or perforated straps not less than 2 inches wide by 10 inches long; or wire anchors not less than 0.177 inch thick.
2. Stud-Wall Type: Designed to engage stud, welded to back of frames; not less than 0.042 inch thick.

B. Floor Anchors: Formed from same material as frames, not less than 0.042 inch thick, and as follows:

1. Monolithic Concrete Slabs: Clip-type anchors, with two holes to receive fasteners.

2.6 STOPS AND MOLDINGS

A. Moldings for Glazed Lites in Doors: Minimum 0.032 inch thick, fabricated from same material as door face sheet in which they are installed.

B. Fixed Frame Moldings: Formed integral with hollow metal frames, a minimum of 5/8 inch high unless otherwise indicated.

C. Loose Stops for Glazed Lites in Frames: Minimum 0.032 inch thick, fabricated from same material as frames in which they are installed.

2.7 LOUVERS

A. Provide louvers for interior doors, where indicated, that comply with SDI 111C, with blades or baffles formed of 0.020-inch- () thick, cold-rolled steel sheet set into 0.032-inch- thick steel frame.

1. Sightproof Louver: Stationary louvers constructed with inverted V-shaped or Y-shaped blades.

2.8 ACCESSORIES

A. Grout Guards: Formed from same material as frames, not less than 0.016 inch thick.

2.9 FABRICATION

A. Fabricate hollow metal work to be rigid and free of defects, warp, or buckle. Accurately form metal to required sizes and profiles, with minimum radius for thickness of metal. Where practical, fit and assemble units in manufacturer's plant. To ensure proper assembly at Project site, clearly identify work that cannot be permanently factory assembled before shipment.

B. Tolerances: Fabricate hollow metal work to tolerances indicated in SDI 117.

C. Hollow Metal Doors:

1. Exterior Doors: Provide weep-hole openings in bottom of exterior doors to permit moisture to escape. Seal joints in top edges of doors against water penetration.
2. Glazed Lites: Factory cut openings in doors.

3. Astragals: Provide overlapping astragal on one leaf of pairs of doors where required by NFPA 80 for fire-performance rating or where indicated. Extend minimum 3/4 inch beyond edge of door on which astragal is mounted.
- D. Hollow Metal Frames: Where frames are fabricated in sections due to shipping or handling limitations, provide alignment plates or angles at each joint, fabricated of same thickness metal as frames.
1. Welded Frames: Weld flush face joints continuously; grind, fill, dress, and make smooth, flush, and invisible.
 2. Sidelight and Transom Bar Frames: Provide closed tubular members with no visible face seams or joints, fabricated from same material as door frame. Fasten members at crossings and to jambs by butt welding.
 3. Provide countersunk, flat- or oval-head exposed screws and bolts for exposed fasteners unless otherwise indicated.
 4. Grout Guards: Weld guards to frame at back of hardware mortises in frames to be grouted.
 5. Floor Anchors: Weld anchors to bottom of jambs and mullions with at least four spot welds per anchor.
 6. Jamb Anchors: Provide number and spacing of anchors as follows:
 - a. Masonry Type: Locate anchors not more than 18 inches from top and bottom of frame. Space anchors not more than 32 inches o.c. and as follows:
 - 1) Two anchors per jamb up to 60 inches high.
 - 2) Three anchors per jamb from 60 to 90 inches high.
 - 3) Four anchors per jamb from 90 to 120 inches high.
 - 4) Four anchors per jamb plus 1 additional anchor per jamb for each 24 inches or fraction thereof above 120 inches high.
 - b. Stud-Wall Type: Locate anchors not more than 18 inches from top and bottom of frame. Space anchors not more than 32 inches o.c. and as follows:
 - 1) Three anchors per jamb up to 60 inches high.
 - 2) Four anchors per jamb from 60 to 90 inches high.
 - 3) Five anchors per jamb from 90 to 96 inches high.
 - 4) Five anchors per jamb plus 1 additional anchor per jamb for each 24 inches or fraction thereof above 96 inches high.
 - 5) Two anchors per head for frames above 42 inches wide and mounted in metal-stud partitions.
 7. Door Silencers: Except on weather-stripped doors, drill stops to receive door silencers as follows. Keep holes clear during construction.
 - a. Single-Door Frames: Drill stop in strike jamb to receive three door silencers.
 - b. Double-Door Frames: Drill stop in head jamb to receive two door silencers.
- E. Fabricate concealed stiffeners, edge channels, and hardware reinforcement from either cold- or hot-rolled steel sheet.
- F. Hardware Preparation: Factory prepare hollow metal work to receive templated mortised hardware; include cutouts, reinforcement, mortising, drilling, and tapping according to the Door Hardware Schedule and templates furnished as specified in Division 08 Section "Door Hardware."
1. Locate hardware as indicated, or if not indicated, according to ANSI/SDI A250.8.
 2. Reinforce doors and frames to receive nontemplated, mortised and surface-mounted door hardware.
 3. Comply with applicable requirements in ANSI/SDI A250.6 and ANSI/DHI A115 Series specifications for preparation of hollow metal work for hardware.

4. Coordinate locations of conduit and wiring boxes for electrical connections with Division 26 Sections.
- G. Stops and Moldings: Provide stops and moldings around glazed lites where indicated. Form corners of stops and moldings with butted or mitered hairline joints.
1. Single Glazed Lites: Provide fixed stops and moldings welded on secure side of hollow metal work.
 2. Multiple Glazed Lites: Provide fixed and removable stops and moldings so that each glazed lite is capable of being removed independently.
 3. Provide fixed frame moldings on outside of exterior and on secure side of interior doors and frames.
 4. Provide loose stops and moldings on inside of hollow metal work.
 5. Coordinate rabbet width between fixed and removable stops with type of glazing and type of installation indicated.

2.10 STEEL FINISHES

- A. Prime Finish: Apply manufacturer's standard primer immediately after cleaning and pretreating.
1. Shop Primer: Manufacturer's standard, fast-curing, lead- and chromate-free primer complying with ANSI/SDI A250.10 acceptance criteria; recommended by primer manufacturer for substrate; compatible with substrate and field-applied coatings despite prolonged exposure.

PART 3 - EXECUTION

3.1 EXAMINATION

- A. Examine substrates, areas, and conditions, with Installer present, for compliance with requirements for installation tolerances and other conditions affecting performance of the Work.
- B. Examine roughing-in for embedded and built-in anchors to verify actual locations before frame installation.
- C. For the record, prepare written report, endorsed by Installer, listing conditions detrimental to performance of the Work.
- D. Proceed with installation only after unsatisfactory conditions have been corrected.

3.2 PREPARATION

- A. Remove welded-in shipping spreaders installed at factory. Restore exposed finish by grinding, filling, and dressing, as required to make repaired area smooth, flush, and invisible on exposed faces.
- B. Prior to installation, adjust and securely brace welded hollow metal frames for squareness, alignment, twist, and plumbness to the following tolerances:
1. Squareness: Plus or minus 1/16 inch , measured at door rabbet on a line 90 degrees from jamb perpendicular to frame head.
 2. Alignment: Plus or minus 1/16 inch , measured at jambs on a horizontal line parallel to plane of wall.

3. Twist: Plus or minus 1/16 inch , measured at opposite face corners of jambs on parallel lines, and perpendicular to plane of wall.
 4. Plumbness: Plus or minus 1/16 inch , measured at jambs on a perpendicular line from head to floor.
- C. Drill and tap doors and frames to receive nontemplated, mortised, and surface-mounted door hardware.

3.3 INSTALLATION

- A. General: Install hollow metal work plumb, rigid, properly aligned, and securely fastened in place; comply with Drawings and manufacturer's written instructions.
- B. Hollow Metal Frames: Install hollow metal frames of size and profile indicated. Comply with ANSI/SDI A250.11 .
1. Set frames accurately in position, plumbed, aligned, and braced securely until permanent anchors are set. After wall construction is complete, remove temporary braces, leaving surfaces smooth and undamaged.
 - a. At fire-protection-rated openings, install frames according to NFPA 80.
 - b. Where frames are fabricated in sections because of shipping or handling limitations, field splice at approved locations by welding face joint continuously; grind, fill, dress, and make splice smooth, flush, and invisible on exposed faces.
 - c. Install frames with removable glazing stops located on secure side of opening.
 - d. Install door silencers in frames before grouting.
 - e. Remove temporary braces necessary for installation only after frames have been properly set and secured.
 - f. Check plumbness, squareness, and twist of frames as walls are constructed. Shim as necessary to comply with installation tolerances.
 - g. Field apply bituminous coating to backs of frames that are filled with grout containing antifreezing agents.
 2. Floor Anchors: Provide floor anchors for each jamb and mullion that extends to floor, and secure with postinstalled expansion anchors.
 - a. Floor anchors may be set with powder-actuated fasteners instead of postinstalled expansion anchors if so indicated and approved on Shop Drawings.
 3. Metal-Stud Partitions: Solidly pack mineral-fiber insulation behind frames.
 4. Masonry Walls: Coordinate installation of frames to allow for solidly filling space between frames and masonry with grout.
 5. In-Place Gypsum Board Partitions: Secure frames in place with postinstalled expansion anchors through floor anchors at each jamb. Countersink anchors, and fill and make smooth, flush, and invisible on exposed faces.
 6. Installation Tolerances: Adjust hollow metal door frames for squareness, alignment, twist, and plumb to the following tolerances:
 - a. Squareness: Plus or minus 1/16 inch , measured at door rabbet on a line 90 degrees from jamb perpendicular to frame head.
 - b. Alignment: Plus or minus 1/16 inch , measured at jambs on a horizontal line parallel to plane of wall.
 - c. Twist: Plus or minus 1/16 inch , measured at opposite face corners of jambs on parallel lines, and perpendicular to plane of wall.
 - d. Plumbness: Plus or minus 1/16 inch , measured at jambs at floor.
- C. Hollow Metal Doors: Fit hollow metal doors accurately in frames, within clearances specified below. Shim as necessary.

1. Non-Fire-Rated Standard Steel Doors:
 - a. Jambs and Head: 1/8 inch plus or minus 1/16 inch .
 - b. Between Edges of Pairs of Doors: 1/8 inch plus or minus 1/16 inch .
 - c. Between Bottom of Door and Top of Threshold: Maximum 3/8 inch .
 - d. Between Bottom of Door and Top of Finish Floor (No Threshold): Maximum 3/4 inch .
 2. Fire-Rated Doors: Install doors with clearances according to NFPA 80.
- D. Glazing: Comply with installation requirements in Division 08 Section "Glazing" and with hollow metal manufacturer's written instructions.
1. Secure stops with countersunk flat- or oval-head machine screws spaced uniformly not more than 9 inches o.c. and not more than 2 inches o.c. from each corner.
- 3.4 ADJUSTING AND CLEANING
- A. Final Adjustments: Check and readjust operating hardware items immediately before final inspection. Leave work in complete and proper operating condition. Remove and replace defective work, including hollow metal work that is warped, bowed, or otherwise unacceptable.
 - B. Remove grout and other bonding material from hollow metal work immediately after installation.
 - C. Prime-Coat Touchup: Immediately after erection, sand smooth rusted or damaged areas of prime coat and apply touchup of compatible air-drying, rust-inhibitive primer.
 - D. Metallic-Coated Surfaces: Clean abraded areas and repair with galvanizing repair paint according to manufacturer's written instructions.

END OF SECTION 081113

SECTION 081416 - FLUSH WOOD DOORS

PART 1 - GENERAL

1.1 RELATED DOCUMENTS

- A. Drawings and general provisions of the Contract, including General and Supplementary Conditions and Division 01 Specification Sections, apply to this Section.

1.2 SUMMARY

- A. Section Includes:
 - 1. Solid-core doors with wood-veneer faces.
 - 2. Factory finishing flush wood doors.
 - 3. Factory fitting flush wood doors to frames and factory machining for hardware.

1.3 ACTION SUBMITTALS

- A. Product Data: For each type of door indicated. Include details of core and edge construction and trim for openings. Include factory-finishing specifications.
- B. Shop Drawings: Indicate location, size, and hand of each door; elevation of each kind of door; construction details not covered in Product Data; location and extent of hardware blocking; and other pertinent data.
 - 1. Indicate dimensions and locations of mortises and holes for hardware.
 - 2. Indicate dimensions and locations of cutouts.
 - 3. Indicate requirements for veneer matching.
 - 4. Indicate doors to be factory finished and finish requirements.
 - 5. Indicate fire-protection ratings for fire-rated doors.
- C. Samples for Initial Selection: For factory-finished doors.
- D. Samples for Verification:
 - 1. Factory finishes applied to actual door face materials, approximately 8 by 10 inches, for each material and finish. For each wood species and transparent finish, provide set of three samples showing typical range of color and grain to be expected in the finished work.

1.4 QUALITY ASSURANCE

- A. Source Limitations: Obtain flush wood doors from single manufacturer.
- B. Quality Standard: In addition to requirements specified, comply with WDMA I.S.1-A, "Architectural Wood Flush Doors."
- C. Fire-Rated Wood Doors: Doors complying with NFPA 80 that are listed and labeled by a qualified testing agency, for fire-protection ratings indicated, based on testing at positive pressure according to NFPA 252 or UL 10C.

1.5 DELIVERY, STORAGE, AND HANDLING

- A. Comply with requirements of referenced standard and manufacturer's written instructions.
- B. Package doors individually in plastic bags or cardboard cartons.
- C. Mark each door on top and bottom rail with opening number used on Shop Drawings.

1.6 PROJECT CONDITIONS

- A. Environmental Limitations: Do not deliver or install doors until spaces are enclosed and weathertight, wet work in spaces is complete and dry, and HVAC system is operating and maintaining ambient temperature and humidity conditions at occupancy levels during the remainder of the construction period.

1.7 WARRANTY

- A. Special Warranty: Manufacturer's standard form in which manufacturer agrees to repair or replace doors that fail in materials or workmanship within specified warranty period.
 - 1. Failures include, but are not limited to, the following:
 - a. Warping (bow, cup, or twist) more than 1/4 inch in a 42-by-84-inch section.
 - b. Telegraphing of core construction in face veneers exceeding 0.01 inch in a 3-inch span.
 - 2. Warranty shall also include installation and finishing that may be required due to repair or replacement of defective doors.
 - 3. Warranty Period for Solid-Core Interior Doors: Life of installation.

PART 2 - PRODUCTS

2.1 MANUFACTURERS

- A. Manufacturers: Subject to compliance with requirements, provide products by one of the following:
 - 1. Algoma Hardwoods, Inc.
 - 2. Eggers Industries.
 - 3. Graham; an Assa Abloy Group company.
 - 4. Marshfield Door Systems, Inc. (Basis of Design)
 - 5. Mohawk Flush Doors, Inc.; a Masonite company.
 - 6. Oshkosh Architectural Door Company.
 - 7. VT Industries Inc.

2.2 DOOR CONSTRUCTION, GENERAL

- A. WDMA I.S.1-A Performance Grade:
 - 1. Heavy Duty unless otherwise indicated.
 - 2. Extra Heavy Duty: public toilets, janitor's closets, assembly spaces, exits, and where indicated.

3. Standard Duty: Closets (not including janitor's closets), private toilets, and where indicated.
- B. Structural-Composite-Lumber-Core Doors:
1. Structural Composite Lumber: WDMA I.S.10.
 - a. Screw Withdrawal, Face: 700 lbf.
 - b. Screw Withdrawal, Edge: 400 lbf.
- C. Fire-Protection-Rated Doors: Provide core specified or mineral core as needed to provide fire-protection rating indicated.
1. Edge Construction: Provide edge construction with intumescent seals concealed by outer stile. Comply with specified requirements for exposed edges.
 2. Pairs: Provide fire-retardant stiles that are listed and labeled for applications indicated without formed-steel edges and astragals. Provide stiles with concealed intumescent seals. Comply with specified requirements for exposed edges.
- D. Mineral-Core Doors:
1. Core: Noncombustible mineral product complying with requirements of referenced quality standard and testing and inspecting agency for fire-protection rating indicated.
 2. Blocking: Provide composite blocking with improved screw-holding capability approved for use in doors of fire-protection ratings indicated as needed to eliminate through-bolting hardware.
 - a. 5-inch midrail blocking, in doors indicated to have exit devices.
 3. Edge Construction: At hinge stiles, provide laminated-edge construction with improved screw-holding capability and split resistance. Comply with specified requirements for exposed edges.

2.3 VENEERED-FACED DOORS FOR TRANSPARENT FINISH

- A. Interior Solid-Core Doors :
1. Grade: Premium, with Grade A faces.
 2. Species: Select Red Oak.
 3. Cut: Plain sliced (flat sliced).
 4. Match between Veneer Leaves: Slip match.
 5. Assembly of Veneer Leaves on Door Faces: Running match.
 6. Core: Structural composite lumber.
 7. Construction: Five plies. Stiles and rails are bonded to core, then entire unit abrasive planed before veneering. Faces are bonded to core using a hot press.

2.4 LOUVERS AND LIGHT FRAMES

- A. Wood Beads for Light Openings in Wood Doors: Provide manufacturer's standard wood beads as follows unless otherwise indicated.
1. Wood Species: Species compatible with door faces.
 2. Profile: Recessed tapered beads.
 3. At wood-core doors with 20-minute fire-protection ratings, provide wood beads and metal glazing clips approved for such use.

- B. Wood-Veneered Beads for Light Openings in Fire-Rated Doors: Manufacturer's standard wood-veneered noncombustible beads matching veneer species of door faces and approved for use in doors of fire-protection rating indicated. Include concealed metal glazing clips where required for opening size and fire-protection rating indicated.

2.5 FABRICATION

- A. Factory fit doors to suit frame-opening sizes indicated. Comply with clearance requirements of referenced quality standard for fitting unless otherwise indicated.
 - 1. Comply with requirements in NFPA 80 for fire-rated doors.
- B. Factory machine doors for hardware that is not surface applied. Locate hardware to comply with DHI-WDHS-3. Comply with final hardware schedules, door frame Shop Drawings, DHI A115-W series standards, and hardware templates.
 - 1. Coordinate with hardware mortises in metal frames to verify dimensions and alignment before factory machining.
- C. Openings: Cut and trim openings through doors in factory.
 - 1. Light Openings: Trim openings with moldings of material and profile indicated.
 - 2. Glazing: Factory install glazing in doors indicated to be factory finished. Comply with applicable requirements in Division 08 Section "Glazing."

2.6 FACTORY FINISHING

- A. General: Comply with referenced quality standard for factory finishing. Complete fabrication, including fitting doors for openings and machining for hardware that is not surface applied, before finishing.
 - 1. Finish faces, all four edges, edges of cutouts, and mortises. Stains and fillers may be omitted on top and bottom edges, edges of cutouts, and mortises.
- B. Finish doors at factory.
- C. Finish doors at factory that are indicated to receive transparent finish. Field finish doors indicated to receive opaque finish.
- D. Finish doors at factory where indicated in schedules or on Drawings as factory finished.
- E. Transparent Finish:
 - 1. Grade: Custom.
 - 2. Finish: WDMA TR-6 catalyzed polyurethane.
 - 3. Staining: As selected by Architect from manufacturer's full range. Basis-of-Design Marshfield "Espresso".
 - 4. Effect: Semifilled finish, produced by applying an additional finish coat to partially fill the wood pores.
 - 5. Sheen: Satin.

PART 3 - EXECUTION

3.1 EXAMINATION

- A. Examine doors and installed door frames before hanging doors.
 - 1. Verify that frames comply with indicated requirements for type, size, location, and swing characteristics and have been installed with level heads and plumb jambs.
 - 2. Reject doors with defects.
- B. Proceed with installation only after unsatisfactory conditions have been corrected.

3.2 INSTALLATION

- A. Hardware: For installation, see Division 08 Section "Door Hardware."
- B. Installation Instructions: Install doors to comply with manufacturer's written instructions and the referenced quality standard, and as indicated.
 - 1. Install fire-rated doors in corresponding fire-rated frames according to NFPA 80.
- C. Job-Fitted Doors: Align and fit doors in frames with uniform clearances and bevels as indicated below; do not trim stiles and rails in excess of limits set by manufacturer or permitted for fire-rated doors. Machine doors for hardware. Seal edges of doors, edges of cutouts, and mortises after fitting and machining.
 - 1. Clearances: Provide 1/8 inch at heads, jambs, and between pairs of doors. Provide 1/8 inch from bottom of door to top of decorative floor finish or covering unless otherwise indicated. Where threshold is shown or scheduled, provide 1/4 inch from bottom of door to top of threshold unless otherwise indicated.
 - a. Comply with NFPA 80 for fire-rated doors.
 - 2. Bevel non-fire-rated doors 1/8 inch in 2 inches at lock and hinge edges.
 - 3. Bevel fire-rated doors 1/8 inch in 2 inches at lock edge; trim stiles and rails only to extent permitted by labeling agency.
- D. Factory-Fitted Doors: Align in frames for uniform clearance at each edge.
- E. Factory-Finished Doors: Restore finish before installation if fitting or machining is required at Project site.

3.3 ADJUSTING

- A. Operation: Rehang or replace doors that do not swing or operate freely.
- B. Finished Doors: Replace doors that are damaged or that do not comply with requirements. Doors may be repaired or refinished if work complies with requirements and shows no evidence of repair or refinishing.

END OF SECTION 081416

SECTION 084113 - ALUMINUM-FRAMED ENTRANCES AND STOREFRONTS

PART 1 - GENERAL

1.1 RELATED DOCUMENTS

- A. Drawings and general provisions of the Contract, including General and Supplementary Conditions and Division 01 Specification Sections, apply to this Section.

1. Exterior manual-swing entrance doors and door-frame units.

1.2 DEFINITIONS

- A. ADA/ABA Accessibility Guidelines: U.S. Architectural & Transportation Barriers Compliance Board's "Americans with Disability Act (ADA) and Architectural Barriers Act (ABA) Accessibility Guidelines for Buildings and Facilities."

1.3 PERFORMANCE REQUIREMENTS

- A. General Performance: Aluminum-framed systems shall withstand the effects of the following performance requirements without exceeding performance criteria or failure due to defective manufacture, fabrication, installation, or other defects in construction:

1. Movements of supporting structure indicated on Drawings including, but not limited to, story drift and deflection from uniformly distributed and concentrated live loads.
2. Dimensional tolerances of building frame and other adjacent construction.
3. Failure includes the following:
 - a. Deflection exceeding specified limits.
 - b. Thermal stresses transferring to building structure.
 - c. Framing members transferring stresses, including those caused by thermal and structural movements to glazing.
 - d. Noise or vibration created by wind and by thermal and structural movements.
 - e. Loosening or weakening of fasteners, attachments, and other components.
 - f. Sealant failure.
 - g. Failure of operating units.

- B. Structural Loads:

1. Wind Loads: As indicated on Drawings..
2. Seismic Loads: As indicated on Drawings.

- C. Deflection of Framing Members:

1. Deflection Normal to Wall Plane: Limited to edge of glass in a direction perpendicular to glass plane shall not exceed $L/175$ of the glass edge length for each individual glazing lite or an amount that restricts edge deflection of individual glazing lites to $3/4$ inch (19 mm), whichever is less.
2. Deflection Parallel to Glazing Plane: Limited to $L/360$ of clear span or $1/8$ inch (3.2 mm), whichever is smaller.

- D. Thermal Movements: Provide aluminum-framed systems that allow for thermal movements resulting from the following maximum change (range) in ambient and surface temperatures. Base engineering calculation on surface temperatures of materials due to both solar heat gain and nighttime-sky heat loss.
1. Temperature Change (Range): 120 deg F (67 deg C), ambient; 180 deg F (100 deg C), material surfaces.
 2. Test Performance: No buckling; stress on glass; sealant failure; excess stress on framing, anchors, and fasteners; or reduction of performance when tested according to AAMA 501.5.
 - a. High Exterior Ambient-Air Temperature: That which produces an exterior metal-surface temperature of 180 deg F (82 deg C).
 - b. Low Exterior Ambient-Air Temperature: 0 deg F (minus 18 deg C).
 - c. Interior Ambient-Air Temperature: 75 deg F (24 deg C).
- E. Condensation Resistance: Provide aluminum-framed systems with fixed glazing and framing areas having condensation-resistance factor (CRF) of not less than 45 when tested according to AAMA 1503.
- F. Thermal Conductance: Provide aluminum-framed systems with fixed glazing and framing areas having an average U-factor of not more than 0.57 Btu/sq. ft. x h x deg F (3.23 W/sq. m x K) when tested according to AAMA 1503.

1.4 ACTION SUBMITTALS

- A. Product Data: For each type of product indicated. Include construction details, material descriptions, dimensions of individual components and profiles, and finishes for aluminum-framed systems.
- B. Shop Drawings: For aluminum-framed systems. Include plans, elevations, sections, details, and attachments to other work.
1. Include details of provisions for system expansion and contraction and for drainage of moisture in the system to the exterior.
 2. For entrance doors, include hardware schedule and indicate operating hardware types, functions, quantities, and locations.
- C. Samples for Verification: For each type of exposed finish required, in manufacturer's standard sizes.

1.5 INFORMATIONAL SUBMITTALS

- A. Qualification Data: For qualified Installer.
- B. Product Test Reports: Based on evaluation of comprehensive tests performed by a qualified testing agency, for aluminum-framed systems, indicating compliance with performance requirements.
- C. Warranties: Sample of special warranties.

1.6 CLOSEOUT SUBMITTALS

- A. Maintenance Data: For aluminum-framed systems to include in maintenance manuals.

1.7 QUALITY ASSURANCE

- A. Manufacturer Qualifications: A manufacturer capable of fabricating glazed aluminum framed storefronts that meet or exceed energy performance requirements indicated and of documenting this performance by certification, labeling, and inclusion in lists.
- B. Single-Source Manufacturer: For glazed aluminum curtainwall and aluminum-framed entrances and storefronts. Obtain from same manufacturer.
- C. Installer Qualifications: Manufacturer's authorized representative who is trained and approved for installation of units required for this Project.
- D. Engineering Responsibility: Prepare data for aluminum-framed systems, including Shop Drawings, based on testing and engineering analysis of manufacturer's standard units in systems similar to those indicated for this Project.
- E. Product Options: Information on Drawings and in Specifications establishes requirements for systems' aesthetic effects and performance characteristics. Aesthetic effects are indicated by dimensions, arrangements, alignment, and profiles of components and assemblies as they relate to sightlines, to one another, and to adjoining construction. Performance characteristics are indicated by criteria subject to verification by one or more methods including preconstruction testing, field testing, and in-service performance.
 - 1. Do not revise intended aesthetic effects, as judged solely by Architect, except with Architect's approval. If revisions are proposed, submit comprehensive explanatory data to Architect for review.
- F. Accessible Entrances: Comply with applicable provisions in the U.S. Architectural & Transportation Barriers Compliance Board's ADA-ABA Accessibility Guidelines and ICC/ANSI A117.1.
- G. Source Limitations for Aluminum-Framed Systems: Obtain from single source from single manufacturer.

1.8 PROJECT CONDITIONS

- A. Field Measurements: Verify actual locations of structural supports for aluminum-framed systems by field measurements before fabrication and indicate measurements on Shop Drawings.

1.9 WARRANTY

- A. Special Warranty: Manufacturer's standard form in which manufacturer agrees to repair or replace components of aluminum-framed systems that do not comply with requirements or that fail in materials or workmanship within specified warranty period.
 - 1. Failures include, but are not limited to, the following:
 - a. Structural failures including, but not limited to, excessive deflection.
 - b. Noise or vibration caused by thermal movements.
 - c. Deterioration of metals and other materials beyond normal weathering.
 - d. Water leakage through fixed glazing and framing areas.
 - e. Failure of operating components.
 - 2. Warranty Period: Two years from date of Substantial Completion.

1.10 MAINTENANCE SERVICE

A. Entrance Door Hardware:

1. Maintenance Tools and Instructions: Furnish a complete set of specialized tools and maintenance instructions as needed for Owner's continued adjustment, maintenance, and removal and replacement of entrance door hardware.

PART 2 - PRODUCTS

2.1 MANUFACTURERS

A. Manufacturers: Subject to compliance with requirements, provide products by one of the following:

1. EFCO Corporation.
2. Kawneer North America; an Alcoa company.
3. Tubelite.
4. YKK AP America Inc.

2.2 MATERIALS

A. Aluminum: Alloy and temper recommended by manufacturer for type of use and finish indicated.

1. Sheet and Plate: ASTM B 209 (ASTM B 209M).
2. Extruded Bars, Rods, Profiles, and Tubes: ASTM B 221 (ASTM B 221M).
3. Extruded Structural Pipe and Tubes: ASTM B 429.
4. Structural Profiles: ASTM B 308/B 308M.

2.3 FRAMING SYSTEMS

A. Framing Members: Manufacturer's standard extruded-aluminum framing members of thickness required and reinforced as required to support imposed loads.

1. Construction: Thermally improved.
2. Glazing System: Retained mechanically with gaskets on four sides.
3. Glazing Plane: Center.

B. Brackets and Reinforcements: Manufacturer's standard high-strength aluminum with nonstaining, nonferrous shims for aligning system components.

C. Fasteners and Accessories: Manufacturer's standard corrosion-resistant, nonstaining, nonbleeding fasteners and accessories compatible with adjacent materials.

1. Use self-locking devices where fasteners are subject to loosening or turning out from thermal and structural movements, wind loads, or vibration.
2. Reinforce members as required to receive fastener threads.
3. Use hidden fasteners where possible.
4. Locate exposed fasteners out of sightlines.

D. Concealed Flashing: Manufacturer's standard corrosion-resistant, nonstaining, nonbleeding flashing compatible with adjacent materials.

- E. Framing System Gaskets and Sealants: Manufacturer's standard, recommended by manufacturer for joint type.

2.4 GLAZING SYSTEMS

- A. Glazing: As specified in Division 08 Section "Glazing."
- B. Glazing Gaskets: Manufacturer's standard compression types; replaceable, molded or extruded, of profile and hardness required to maintain watertight seal.
- C. Spacers and Setting Blocks: Manufacturer's standard elastomeric type.

2.5 ENTRANCE DOOR SYSTEMS

- A. Entrance Doors: Manufacturer's standard glazed entrance doors for manual-swing operation.
 - 1. Door Construction: 2-inch (44.5-mm) overall thickness, with minimum -3/16 inch (3.2-mm-) thick, extruded-aluminum tubular rail and stile members. Mechanically fasten corners with reinforcing brackets that are deeply penetrated and fillet welded or that incorporate concealed tie rods.
 - 2. Door Design: Wide stile; 5-inch (127-mm) nominal width. Basis-of-Design Product: YKK: "50M" or Kawneer "500 Heavy Wall Entrance".
 - a. Accessible Doors: Smooth surfaced for width of door in area within 10 inches (255 mm) above floor or ground plane.
 - 3. Glazing Stops and Gaskets: Beveled, snap-on, extruded-aluminum stops and preformed gaskets.
 - a. Provide nonremovable glazing stops on outside of door.
- B. Entrance Door Hardware: As specified in Division 08 Section "Door Hardware."
 - a. Coordinate with power-assist operators.

2.6 ACCESSORY MATERIALS

- A. Joint Sealants: For installation at perimeter of aluminum-framed systems, as specified in Division 07 Section "Joint Sealants."
- B. Bituminous Paint: Cold-applied, asphalt-mastic paint complying with SSPC-Paint 12 requirements except containing no asbestos; formulated for 30-mil (0.762-mm) thickness per coat.

2.7 FABRICATION

- A. Form or extrude aluminum shapes before finishing.
- B. Framing Members, General: Fabricate components that, when assembled, have the following characteristics:
 - 1. Profiles that are sharp, straight, and free of defects or deformations.
 - 2. Accurately fitted joints with ends coped or mitered.

3. Means to drain water passing joints, condensation within framing members, and moisture migrating within the system to exterior.
 4. Physical and thermal isolation of glazing from framing members.
 5. Accommodations for thermal and mechanical movements of glazing and framing to maintain required glazing edge clearances.
 6. Fasteners, anchors, and connection devices that are concealed from view to greatest extent possible.
- C. Entrance Door Frames: Reinforce as required to support loads imposed by door operation and for installing entrance door hardware.
1. At exterior doors, provide compression weather stripping at fixed stops.
- D. Entrance Doors: Reinforce doors as required for installing entrance door hardware.
1. At pairs of exterior doors, provide sliding-type weather stripping retained in adjustable strip and mortised into door edge.
 2. At exterior doors, provide weather sweeps applied to door bottoms.
- E. Entrance Door Hardware Installation: Factory install entrance door hardware to the greatest extent possible. Cut, drill, and tap for factory-installed entrance door hardware before applying finishes.
- F. After fabrication, clearly mark components to identify their locations in Project according to Shop Drawings.

2.8 ALUMINUM FINISHES

- A. Interior storefront as indicated on drawings - Clear Anodic Finish: AAMA 611, AA-M12C22A41, Class I, .7 mils min.
- B. Exterior storefront as indicated on drawings - Dark Bronze to match existing: AAMA 611 & DAF-45, AA-M12C22A44, Class I, .7 mils min.

PART 3 - EXECUTION

3.1 EXAMINATION

- A. Examine areas and conditions, with Installer present, for compliance with requirements for installation tolerances and other conditions affecting performance of the Work.
- B. Proceed with installation only after unsatisfactory conditions have been corrected.

3.2 INSTALLATION

- A. General:
 1. Comply with manufacturer's written instructions.
 2. Do not install damaged components.
 3. Fit joints to produce hairline joints free of burrs and distortion.
 4. Rigidly secure nonmovement joints.
 5. Install anchors with separators and isolators to prevent metal corrosion and electrolytic deterioration.
 6. Seal joints watertight unless otherwise indicated.

- B. Metal Protection:
 - 1. Where aluminum will contact dissimilar metals, protect against galvanic action by painting contact surfaces with primer or applying sealant or tape, or by installing nonconductive spacers as recommended by manufacturer for this purpose.
 - 2. Where aluminum will contact concrete or masonry, protect against corrosion by painting contact surfaces with bituminous paint.
- C. Install components to drain water passing joints, condensation occurring within framing members, and moisture migrating within the system to exterior.
- D. Set continuous sill members and flashing in full sealant bed as specified in Division 07 Section "Joint Sealants" to produce weathertight installation.
- E. Install components plumb and true in alignment with established lines and grades, and without warp or rack.
- F. Install glazing as specified in Division 08 Section "Glazing."
- G. Entrance Doors: Install doors to produce smooth operation and tight fit at contact points.
 - 1. Exterior Doors: Install to produce weathertight enclosure and tight fit at weather stripping.
 - 2. Field-Installed Entrance Door Hardware: Install surface-mounted entrance door hardware according to entrance door hardware manufacturers' written instructions using concealed fasteners to greatest extent possible.
- H. Install perimeter joint sealants as specified in Division 07 Section "Joint Sealants" to produce weathertight installation.

3.3 ERECTION TOLERANCES

- A. Install aluminum-framed systems to comply with the following maximum erection tolerances:
 - 1. Location and Plane: Limit variation from true location and plane to 1/8 inch in 12 feet (3 mm in 3.7 m); 1/4 inch (6 mm) over total length.
 - 2. Alignment:
 - a. Where surfaces abut in line, limit offset from true alignment to 1/16 inch (1.5 mm).
 - b. Where surfaces meet at corners, limit offset from true alignment to 1/32 inch (0.8 mm).
- B. Diagonal Measurements: Limit difference between diagonal measurements to 1/8 inch (3 mm).

3.4 FIELD QUALITY CONTROL

- A. Testing Agency: Engage a qualified independent testing and inspecting agency to perform field tests and inspections.
- B. Testing Services: Testing and inspecting of representative areas to determine compliance of installed systems with specified requirements.
 - 1. Water Spray Test: Before installation of interior finishes has begun, a minimum area of 75 feet (23 m) by 1 story of aluminum-framed systems designated by Architect shall be tested according to AAMA 501.2 and shall not evidence water penetration.

- C. Aluminum-framed assemblies will be considered defective if they do not pass tests and inspections.
- D. Prepare test and inspection reports.

3.5 ADJUSTING

- A. Adjust operating entrance door hardware to function smoothly as recommended by manufacturer.
 - 1. For entrance doors accessible to people with disabilities, adjust closers to provide a 3-second closer sweep period for doors to move from a 70-degree open position to 3 inches (75 mm) from the latch, measured to the leading door edge.

END OF SECTION 084113

SECTION 087100 - DOOR HARDWARE

PART 1 - GENERAL

1.1 RELATED DOCUMENTS

- A. Drawings and general provisions of the Contract, including General and Supplementary Conditions and Division 01 Specification Sections, apply to this Section.

1.2 SUMMARY

- A. Section includes:
 - 1. Mechanical door hardware for the following:
 - a. Swinging doors.
 - 2. Cylinders for door hardware specified in other Sections.
 - 3. Electrified door hardware.

1.3 ACTION SUBMITTALS

- A. Product Data: For each type of product indicated. Include construction and installation details, material descriptions, dimensions of individual components and profiles, and finishes.
- B. Shop Drawings: Details of electrified door hardware, indicating the following:
 - 1. Wiring Diagrams: For power, signal, and control wiring and including the following:
 - a. Details of interface of electrified door hardware and building safety and security systems.
 - b. Schematic diagram of systems that interface with electrified door hardware.
 - c. Point-to-point wiring.
 - d. Risers.
 - e. Elevations doors controlled by electrified door hardware.
 - 2. Operation Narrative: Describe the operation of doors controlled by electrified door hardware.
- C. Other Action Submittals:
 - 1. Door Hardware Schedule: Prepared by or under the supervision of Installer, detailing fabrication and assembly of door hardware, as well as installation procedures and diagrams. Coordinate final door hardware schedule with doors, frames, and related work to ensure proper size, thickness, hand, function, and finish of door hardware.
 - a. Submittal Sequence: Submit door hardware schedule concurrent with submissions of Product Data, Samples, and Shop Drawings. Coordinate submission of door hardware schedule with scheduling requirements of other work to facilitate the fabrication of other work that is critical in Project construction schedule.
 - b. Format: Use same scheduling sequence and format and use same door numbers as in the Contract Documents.

c. Content: Include the following information:

- 1) Identification number, location, hand, fire rating, size, and material of each door and frame.
 - 2) Locations of each door hardware set, cross-referenced to Drawings on floor plans and to door and frame schedule.
 - 3) Complete designations, including name and manufacturer, type, style, function, size, quantity, function, and finish of each door hardware product.
 - 4) Description of electrified door hardware sequences of operation and interfaces with other building control systems.
 - 5) Fastenings and other pertinent information.
 - 6) Explanation of abbreviations, symbols, and codes contained in schedule.
 - 7) Mounting locations for door hardware.
 - 8) List of related door devices specified in other Sections for each door and frame.
2. Keying Schedule: Prepared by or under the supervision of Installer, detailing Owner's final keying instructions for locks. Include schematic keying diagram and index each key set to unique door designations that are coordinated with the Contract Documents.

1.4 INFORMATIONAL SUBMITTALS

- A. Qualification Data: For Installer and Architectural Hardware Consultant.
- B. Product Certificates: For electrified door hardware, from the manufacturer.
1. Certify that door hardware approved for use on types and sizes of labeled fire-rated doors complies with listed fire-rated door assemblies.
- C. Product Test Reports: For compliance with accessibility requirements, based on evaluation of comprehensive tests performed by manufacturer and witnessed by a qualified testing agency, for door hardware on doors located in accessible routes.
- D. Warranty: Special warranty specified in this Section.

1.5 CLOSEOUT SUBMITTALS

- A. Maintenance Data: For each type of door hardware to include in maintenance manuals. Include final hardware and keying schedule.

1.6 QUALITY ASSURANCE

- A. Supplier Qualifications: Supplier of products and an employer of workers trained and approved by product manufacturers and an Architectural Hardware Consultant who is available during the course of the Work to consult with Contractor, Architect, and Owner about door hardware and keying.
1. Scheduling Responsibility: Preparation of door hardware and keying schedules.
 2. Engineering Responsibility: Preparation of data for electrified door hardware, including Shop Drawings, based on testing and engineering analysis of manufacturer's standard units in assemblies similar to those indicated for this Project.
- B. Architectural Hardware Consultant Qualifications: A person who is experienced in providing consulting services for door hardware installations that are comparable in material, design, and extent to that indicated for this Project and who is currently certified by DHI as follows:

1. For door hardware, an Architectural Hardware Consultant (AHC) who is also an Electrified Hardware Consultant (EHC).
- C. Installer Qualifications: An experienced Architectural Hardware installer who has completed door hardware installations of similar material, design, and extent to that indicated for this Project and whose work has resulted in construction with a record of successful inservice performance.
- D. Source Limitations: Obtain each type of door hardware from a single manufacturer.
1. Provide electrified door hardware from same manufacturer as mechanical door hardware, unless otherwise indicated. Manufacturers that perform electrical modifications and that are listed by a testing and inspecting agency acceptable to authorities having jurisdiction are acceptable.
- E. Fire-Rated Door Assemblies: Where fire-rated door assemblies are indicated, provide door hardware rated for use in assemblies complying with NFPA 80 that are listed and labeled by a qualified testing agency, for fire-protection ratings indicated, based on testing at positive pressure according to NFPA 252 or UL 10C, unless otherwise indicated.
- F. Smoke- and Draft-Control Door Assemblies: Where smoke- and draft-control door assemblies are required, provide door hardware that meet requirements of assemblies tested according to UL 1784 and installed in compliance with NFPA 105.
1. Air Leakage Rate: Maximum air leakage of 0.3 cfm/sq. ft. at the tested pressure differential of 0.3-inch wg of water.
- G. Electrified Door Hardware: Listed and labeled as defined in NFPA 70, Article 100, by a testing agency acceptable to authorities having jurisdiction.
- H. Means of Egress Doors: Latches do not require more than 15 lbf to release the latch. Locks do not require use of a key, tool, or special knowledge for operation.
- I. Accessibility Requirements: For door hardware on doors in an accessible route, comply with the U.S. Architectural & Transportation Barriers Compliance Board's ADA-ABA Accessibility Guidelines and ICC/ANSI A117.1.
1. Provide operating devices that do not require tight grasping, pinching, or twisting of the wrist and that operate with a force of not more than 5 lbf.
 2. Comply with the following maximum opening-force requirements:
 - a. Interior, Non-Fire-Rated Hinged Doors: 5 lbf applied perpendicular to door.
 - b. Fire Doors: Minimum opening force allowable by authorities having jurisdiction.
 3. Bevel raised thresholds with a slope of not more than 1:2. Provide thresholds not more than 1/2 inch high.
 4. Adjust door closer sweep periods so that, from an open position of 70 degrees, the door will take at least 3 seconds to move to a point 3 inches from the latch, measured to the leading edge of the door.
- J. Keying Conference: Conduct conference at Project site. to comply with requirements in Division 01 Section "Project Management and Coordination." In addition to Owner Contractor, and Architect, conference participants shall also include Installer's Architectural Hardware Consultant and Owner's security consultant. Incorporate keying conference decisions into final keying schedule after reviewing door hardware keying system including, but not limited to, the following:
1. Function of building, flow of traffic, purpose of each area, degree of security required, and plans for future expansion.
 2. Preliminary key system schematic diagram.
 3. Requirements for key control system.

4. Requirements for access control.
5. Address for delivery of keys.

K. Pre-installation Conference: Conduct conference at Project site.

1. Review and finalize construction schedule and verify availability of materials, Installer's personnel, equipment, and facilities needed to make progress and avoid delays.
2. Inspect and discuss preparatory work performed by other trades.
3. Inspect and discuss electrical Roughingin for electrified door hardware.
4. Review sequence of operation for each type of electrified door hardware.
5. Review required testing, inspecting, and certifying procedures.

1.7 DELIVERY, STORAGE, AND HANDLING

- A. Inventory door hardware on receipt and provide secure lockup for door hardware delivered to Project site.
- B. Tag each item or package separately with identification coordinated with the final door hardware schedule, and include installation instructions, templates, and necessary fasteners with each item or package.
- C. Deliver keys and permanent cores to Owner by registered mail or overnight package service.

1.8 COORDINATION

- A. Coordinate layout and installation of floor-recessed door hardware with floor construction. Cast anchoring inserts into concrete. Concrete, reinforcement, and formwork requirements are specified in Division 03.
- B. Installation Templates: Distribute for doors, frames, and other work specified to be factory prepared. Check Shop Drawings of other work to confirm that adequate provisions are made for locating and installing door hardware to comply with indicated requirements.
- C. Security: Coordinate installation of door hardware, keying, and access control with Owner's security consultant.
- D. Electrical System Roughing-In: Coordinate layout and installation of electrified door hardware with connections to power supplies and building safety and security systems.
- E. Existing Openings: Where hardware components are scheduled for application to existing construction or where modifications to existing door hardware are required, field verify existing conditions and coordinate installation of door hardware to suit opening conditions and to provide proper door operation.

1.9 WARRANTY

- A. Special Warranty: Manufacturer's standard form in which manufacturer agrees to repair or replace components of door hardware that fail in materials or workmanship within specified warranty period.
 1. Failures include, but are not limited to, the following:
 - a. Structural failures including excessive deflection, cracking, or breakage.
 - b. Faulty operation of doors and door hardware.

- c. Deterioration of metals, metal finishes, and other materials beyond normal weathering and use.
2. Warranty Period: Three years material and one-year labor from date of Substantial Completion, unless otherwise indicated.
 - a. Locks: Five years from date of Substantial Completion.
 - b. Exit Devices: Two years from date of Substantial Completion.
 - c. Manual Closers: 10 years from date of Substantial Completion.
 - d. Concealed Floor Closers: 10 years from date of Substantial Completion.

1.10 MAINTENANCE SERVICE

- A. Maintenance Tools and Instructions: Furnish a complete set of specialized tools and maintenance instructions for Owner's continued adjustment, maintenance, and removal and replacement of door hardware.
- B. Maintenance Service: Beginning at Substantial Completion, provide six months' full maintenance by skilled employees of door hardware Installer. Include quarterly preventive maintenance, repair or replacement of worn or defective components, lubrication, cleaning, and adjusting as required for proper door and door hardware operation. Provide parts and supplies that are the same as those used in the manufacture and installation of original products.
 1. Consult with and instruct Owner's personnel in recommended adjustments to hardware, and additions to the maintenance procedures.
 2. Prepare a written report of current repairs to hardware and predictable performance problems of substantial nature.

PART 2 - PRODUCTS

2.1 SCHEDULED DOOR HARDWARE

- A. Provide door hardware for each door as scheduled in Part 3 "Door Hardware Schedule" Article to comply with requirements in this Section.
 1. Door Hardware Sets: Provide quantity, item, size, finish or color indicated, and products equivalent in function and comparable in quality to named products.
 2. Sequence of Operation: Provide electrified door hardware function, sequence of operation, and interface with other building control systems indicated.
- B. Designations: Requirements for design, grade, function, finish, size, and other distinctive qualities of each type of door hardware are indicated in Part 3 "Door Hardware Schedule" Article. Products are identified by using door hardware designations, as follows:
 1. Named Manufacturers' Products: Manufacturer and product designation are listed for each door hardware type required for the purpose of establishing minimum requirements. Manufacturers' names are abbreviated in Part 3 "Door Hardware Schedule" Article.
 2. References to BHMA Designations: Provide products complying with these designations and requirements for description, quality, and function.

2.2 HINGES

- A. Hinges: BHMA A156.1. Provide template-produced hinges for hinges installed on hollow-metal doors and hollow-metal frames.

1. Basis-of-Design Product: Subject to compliance with requirements, provide product indicated on schedule or comparable product by one of the following:
 - a. Bommer Industries, Inc.
 - b. Hager Companies (basis of design).
 - c. IVES Hardware; an Ingersoll-Rand company.
 - d. McKinney Products Company; an ASSA ABLOY Group company.
 - e. Stanley Commercial Hardware; Div. of The Stanley Works.

2.3 MECHANICAL LOCKS AND LATCHES

- A. Lock Throw: Comply with testing requirements for length of bolts required for labeled fire doors, and as follows:
 1. Mortise Locks: Minimum 3/4-inch latchbolt throw.
 2. Deadbolts: Minimum 1-inch bolt throw.
- B. Lock Backset: 2-3/4 inches, unless otherwise indicated.
- C. Lock Trim:
 1. Levers: Cast.
 2. Escutcheons (Roses): Wrought.
 3. Dummy Trim: Match lever lock trim and escutcheons.
 4. Operating Device: Lever with escutcheons (roses).
- D. Strikes: Provide manufacturer's standard strike for each lock bolt or latchbolt complying with requirements indicated for applicable lock or latch and with strike box and curved lip extended to protect frame; finished to match lock or latch.
 1. Flat-Lip Strikes: For locks with three-piece antifriction latchbolts, as recommended by manufacturer.
 2. Aluminum-Frame Strike Box: Manufacturer's special strike box fabricated for aluminum framing.
 3. Rabbet Front and Strike: Provide on locksets for rabbeted meeting stiles.
- E. Mortise Locks: BHMA A156.13; Operational Grade 1; stamped steel case with steel or brass parts; Series 1000.
 1. Basis-of-Design Product: Subject to compliance with requirements, provide product indicated on schedule or comparable product by one of the following:
 - a. Corbin Russwin Architectural Hardware; an ASSA ABLOY Group company (basis of design).
 - b. SARGENT Manufacturing Company; an ASSA ABLOY Group company.
 - c. Yale Security Inc.; an ASSA ABLOY Group company.

2.4 ELECTRIC STRIKES

- A. Electric Strikes: BHMA A156.31; Grade 1; with faceplate to suit lock and frame.

2.5 ELECTROMAGNETIC LOCKS

- A. Electromagnetic Locks: BHMA A156.23; electrically powered; with electromagnet attached to frame and armature plate attached to door; full-exterior or full-interior type, as required by application indicated.

2.6 SURFACE BOLTS

- A. Surface Bolts: BHMA A156.16.

2.7 MANUAL FLUSH BOLTS

- A. Manual Flush Bolts: BHMA A156.16; minimum 3/4-inch throw; designed for mortising into door edge.
 - 1. Manufacturers: Subject to compliance with requirements, provide products by one of the following:
 - a. Door Controls International, Inc.
 - b. IVES Hardware; an Ingersoll-Rand company.
 - c. Trimco.

2.8 AUTOMATIC AND SELF-LATCHING FLUSH BOLTS

- A. Automatic and Self-Latching Flush Bolts: BHMA A156.16; minimum 3/4-inch throw; designed for mortising into door edge.
 - 1. Manufacturers: Subject to compliance with requirements, provide products by one of the following:
 - a. Door Controls International, Inc.
 - b. IVES Hardware; an Ingersoll-Rand company.
 - c. Trimco.

2.9 EXIT DEVICES AND AUXILIARY ITEMS

- A. Exit Devices and Auxiliary Items: BHMA A156.3.
 - 1. Basis-of-Design Product: Subject to compliance with requirements, provide product indicated on schedule or comparable product by one of the following:
 - a. Adams Rite Manufacturing Co.; an ASSA ABLOY Group company.
 - b. Corbin Russwin Architectural Hardware; an ASSA ABLOY Group company (basis of design).
 - c. Von Duprin; an Ingersoll-Rand company.

2.10 LOCK CYLINDERS

- A. Lock Cylinders: Tumbler type, constructed from brass or bronze, stainless steel, or nickel silver.
 - 1. Manufacturer: Same manufacturer as for locking devices.

- B. Standard Lock Cylinders: BHMA A156.5; Grade 2; permanent cores that are interchangeable; face finished to match lockset.
- C. Construction Cores: Provide construction cores that are replaceable by permanent cores. Provide 10 construction master keys.

2.11 KEYING

- A. Keying System: Factory registered, complying with guidelines in BHMA A156.28, Appendix A. Incorporate decisions made in keying conference.
 - 1. Grand Master Key System: Change keys, a master key, and a grand master key operate cylinders.
 - 2. Existing System:
 - a. Master key or grand master key locks to Owner's existing system.
- B. Keys: Nickel silver.
 - 1. Stamping: Permanently inscribe each key with a visual key control number and include the following notation:
 - a. Notation: Information to be furnished by Owner.
 - 2. Quantity: In addition to one extra key blank for each lock, provide the following:
 - a. Cylinder Change Keys: Three.
 - b. Master Keys: Five.

2.12 KEY CONTROL SYSTEM

- A. Key Control Cabinet: BHMA A156.5; metal cabinet with baked-enamel finish; containing key-holding hooks, labels, 2 sets of key tags with self-locking key holders, key-gathering envelopes, and temporary and permanent markers; with key capacity of 150 percent of the number of locks.
 - 1. Wall-Mounted Cabinet: Cabinet with hinged-panel door equipped with key-holding panels and pin-tumbler cylinder door lock.

2.13 OPERATING TRIM

- A. Operating Trim: BHMA A156.6; stainless steel, unless otherwise indicated.

2.14 ACCESSORIES FOR PAIRS OF DOORS

- A. Coordinators: BHMA A156.3; consisting of active-leaf, hold-open lever and inactive-leaf release trigger; fabricated from steel with nylon-coated strike plates; with built-in, adjustable safety release; and with internal override.
- B. Astragals: BHMA A156.22.

2.15 SURFACE CLOSERS

- A. Surface Closers: BHMA A156.4; rack-and-pinion hydraulic type with adjustable sweep and latch speeds controlled by key-operated valves and forged-steel main arm. Comply with manufacturer's written recommendations for size of door closers depending on size of door, exposure to weather, and anticipated frequency of use. Provide factory-sized closers, adjustable to meet field conditions and requirements for opening force.
1. Basis-of-Design Product: Subject to compliance with requirements, provide product indicated on schedule or comparable product by one of the following:
 - a. Corbin Russwin Architectural Hardware; an ASSA ABLOY Group company (basis of design).
 - b. LCN Closers; an Ingersoll-Rand company.
 - c. Norton Door Controls; an ASSA ABLOY Group company.
 - d. Rixson Specialty Door Controls; an ASSA ABLOY Group company.

2.16 CLOSER HOLDER RELEASE DEVICES

- A. Closer Holder Release Devices: BHMA A156.15; Grade 1; closer connected with separate or integral releasing and fire- or smoke-detecting devices. Door shall become self-closing on interruption of signal to release device. Automatic release is activated by smoke detection system.
1. Manufacturers: Subject to compliance with requirements, provide products by one of the following:
 - a. LCN Closers; an Ingersoll-Rand company.
 - b. Rixson Specialty Door Controls; an ASSA ABLOY Group company.
 - c. SARGENT Manufacturing Company; an ASSA ABLOY Group company.

2.17 MECHANICAL STOPS AND HOLDERS

- A. Wall- and Floor-Mounted Stops: BHMA A156.16; polished cast brass, bronze, or aluminum base metal.
1. Basis-of-Design Product: Subject to compliance with requirements, provide product indicated on schedule or comparable product by one of the following:
 - a. Hager Companies.
 - b. Rockwood Manufacturing Company (basis of design).
 - c. Stanley Commercial Hardware; Div. of The Stanley Works.

2.18 OVERHEAD STOPS AND HOLDERS

- A. Overhead Stops and Holders: BHMA A156.8.
1. Manufacturers: Subject to compliance with requirements, provide products by one of the following:
 - a. Architectural Builders Hardware Mfg., Inc.
 - b. Glynn-Johnson; an Ingersoll-Rand company.
 - c. Rockwood Manufacturing Company.
 - d. SARGENT Manufacturing Company; an ASSA ABLOY Group company.

2.19 DOOR GASKETING

- A. Door Gasketing: BHMA A156.22; air leakage not to exceed 0.50 cfm per foot of crack length for gasketing other than for smoke control, as tested according to ASTM E 283; with resilient or flexible seal strips that are easily replaceable and readily available from stocks maintained by manufacturer.
 - 1. Manufacturers: Subject to compliance with requirements, provide products by one of the following:
 - a. Hager Companies.
 - b. National Guard Products.
 - c. Pemko Manufacturing Co.; an ASSA ABLOY Group company.
 - d. Reese Enterprises, Inc.
 - e. Zero International.

2.20 THRESHOLDS

- A. Thresholds: BHMA A156.21; fabricated to full width of opening indicated.
 - 1. Manufacturers: Subject to compliance with requirements, provide products by one of the following:
 - a. Hager Companies.
 - b. National Guard Products.
 - c. Pemko Manufacturing Co.; an ASSA ABLOY Group company.
 - d. Reese Enterprises, Inc.
 - e. Zero International.

2.21 METAL PROTECTIVE TRIM UNITS

- A. Metal Protective Trim Units: BHMA A156.6; fabricated from 0.050-inch- thick stainless steel; with manufacturer's standard machine or self-tapping screw fasteners.

2.22 FABRICATION

- A. Manufacturer's Nameplate: Do not provide products that have manufacturer's name or trade name displayed in a visible location except in conjunction with required fire-rated labels and as otherwise approved by Architect.
 - 1. Manufacturer's identification is permitted on rim of lock cylinders only.
- B. Base Metals: Produce door hardware units of base metal indicated, fabricated by forming method indicated, using manufacturer's standard metal alloy, composition, temper, and hardness. Furnish metals of a quality equal to or greater than that of specified door hardware units and BHMA A156.18.
- C. Fasteners: Provide door hardware manufactured to comply with published templates prepared for machine, wood, and sheet metal screws. Provide screws that comply with commercially recognized industry standards for application intended, except aluminum fasteners are not permitted. Provide Phillips flat-head screws with finished heads to match surface of door hardware, unless otherwise indicated.

1. Concealed Fasteners: For door hardware units that are exposed when door is closed, except for units already specified with concealed fasteners. Do not use through bolts for installation where bolt head or nut on opposite face is exposed unless it is the only means of securely attaching the door hardware. Where through bolts are used on hollow door and frame construction, provide sleeves for each through bolt.
2. Fire-Rated Applications:
 - a. Wood or Machine Screws: For the following:
 - 1) Hinges mortised to doors or frames; use threaded-to-the-head wood screws for wood doors and frames.
 - 2) Strike plates to frames.
 - 3) Closers to doors and frames.
 - b. Steel Through Bolts: For the following unless door blocking is provided:
 - 1) Surface hinges to doors.
 - 2) Closers to doors and frames.
 - 3) Surface-mounted exit devices.
3. Spacers or Sex Bolts: For through bolting of hollow-metal doors.
4. Fasteners for Wood Doors: Comply with requirements in DHI WDHS.2, "Recommended Fasteners for Wood Doors."
5. Gasketing Fasteners: Provide noncorrosive fasteners for exterior applications and elsewhere as indicated.

2.23 FINISHES

- A. Provide finishes complying with BHMA A156.18 as indicated in door hardware schedule.
 1. Typical Finish: Chrome, satin finish, US26D
- B. Protect mechanical finishes on exposed surfaces from damage by applying a strippable, temporary protective covering before shipping.
- C. Appearance of Finished Work: Variations in appearance of abutting or adjacent pieces are acceptable if they are within one-half of the range of approved Samples. Noticeable variations in the same piece are not acceptable. Variations in appearance of other components are acceptable if they are within the range of approved Samples and are assembled or installed to minimize contrast.

PART 3 - EXECUTION

3.1 EXAMINATION

- A. Examine doors and frames, with Installer present, for compliance with requirements for installation tolerances, labeled fire-rated door assembly construction, wall and floor construction, and other conditions affecting performance.
- B. Examine roughing-in for electrical power systems to verify actual locations of wiring connections before electrified door hardware installation.
- C. Proceed with installation only after unsatisfactory conditions have been corrected.

3.2 PREPARATION

- A. Steel Doors and Frames: For surface applied door hardware, drill and tap doors and frames according to ANSI/SDI A250.6.
- B. Wood Doors: Comply with DHI WDHS.5 "Recommended Hardware Reinforcement Locations for Mineral Core Wood Flush Doors."

3.3 INSTALLATION

- A. Mounting Heights: Mount door hardware units at heights to comply with the following unless otherwise indicated or required to comply with governing regulations.
 - 1. Standard Steel Doors and Frames: ANSI/SDI A250.8.
 - 2. Wood Doors: DHI WDHS.3, "Recommended Locations for Architectural Hardware for Wood Flush Doors."
- B. Install each door hardware item to comply with manufacturer's written instructions. Where cutting and fitting are required to install door hardware onto or into surfaces that are later to be painted or finished in another way, coordinate removal, storage, and reinstallation of surface protective trim units with finishing work specified in Division 09 Sections. Do not install surface-mounted items until finishes have been completed on substrates involved.
 - 1. Set units level, plumb, and true to line and location. Adjust and reinforce attachment substrates as necessary for proper installation and operation.
 - 2. Drill and countersink units that are not factory prepared for anchorage fasteners. Space fasteners and anchors according to industry standards.
- C. Hinges: Install types and in quantities indicated in door hardware schedule but not fewer than the number recommended by manufacturer for application indicated or one hinge for every 30 inches of door height, whichever is more stringent, unless other equivalent means of support for door, such as spring hinges or pivots, are provided.
- D. Intermediate Offset Pivots: Where offset pivots are indicated, provide intermediate offset pivots in quantities indicated in door hardware schedule but not fewer than one intermediate offset pivot per door and one additional intermediate offset pivot for every 30 inches of door height greater than 90 inches.
- E. Lock Cylinders: Install construction cores to secure building and areas during construction period.
 - 1. Replace construction cores with permanent cores as indicated in keying schedule.
- F. Key Control System: Tag keys and place them on markers and hooks in key control system cabinet, as determined by final keying schedule.
- G. Boxed Power Supplies: Locate power supplies as indicated or, if not indicated, above accessible ceilings. Verify location with Architect.
 - 1. Configuration: Provide one power supply for each door opening with electrified door hardware.
- H. Thresholds: Set thresholds for exterior doors and other doors indicated in full bed of sealant complying with requirements specified in Division 07 Section "Joint Sealants."
- I. Stops: Provide floor stops for doors unless wall or other type stops are indicated in door hardware schedule. Do not mount floor stops where they will impede traffic.

- J. Perimeter Gasketing: Apply to head and jamb, forming seal between door and frame.
- K. Meeting Stile Gasketing: Fasten to meeting stiles, forming seal when doors are closed.
- L. Door Bottoms: Apply to bottom of door, forming seal with threshold when door is closed.

3.4 FIELD QUALITY CONTROL

- A. Independent Architectural Hardware Consultant: Engage a qualified independent Architectural Hardware Consultant to perform inspections and to prepare inspection reports.
 - 1. Independent Architectural Hardware Consultant will inspect door hardware and state in each report whether installed work complies with or deviates from requirements, including whether door hardware is properly installed and adjusted.

3.5 ADJUSTING

- A. Initial Adjustment: Adjust and check each operating item of door hardware and each door to ensure proper operation or function of every unit. Replace units that cannot be adjusted to operate as intended. Adjust door control devices to compensate for final operation of heating and ventilating equipment and to comply with referenced accessibility requirements.
 - 1. Spring Hinges: Adjust to achieve positive latching when door is allowed to close freely from an open position of 30 degrees.
 - 2. Electric Strikes: Adjust horizontal and vertical alignment of keeper to properly engage lock bolt.
 - 3. Door Closers: Adjust sweep period to comply with accessibility requirements and requirements of authorities having jurisdiction.
- B. Occupancy Adjustment: Approximately six months after date of Substantial Completion, Installer's Architectural Hardware Consultant shall examine and readjust each item of door hardware, including adjusting operating forces, as necessary to ensure function of doors, door hardware, and electrified door hardware.

3.6 CLEANING AND PROTECTION

- A. Clean adjacent surfaces soiled by door hardware installation.
- B. Clean operating items as necessary to restore proper function and finish.
- C. Provide final protection and maintain conditions that ensure that door hardware is without damage or deterioration at time of Substantial Completion.

3.7 DEMONSTRATION

- A. Engage a factory-authorized service representative to train Owner's maintenance personnel to adjust, operate, and maintain door hardware and door hardware finishes. Refer to Division 01 Section "Demonstration and Training."

3.8 DOOR HARDWARE SCHEDULE

All hardware to be US26D finish, unless noted otherwise.

Specific hardware indicated is provided for intent only. Alternate manufacturers of equal quality may be submitted for consideration.

Hardware Set 1

(101A, 102A, 103A, 104A, 105A, 106A, 107A, 108A, 109A, 110A, 112A, 113A, 114A)

1.5 pair hinges (Hager BB1279)

- 1 mortised lockset (Corbin Russwin ML2053-NSF)
- 1 wall stop (Rockwood 409)

Hardware Set 2

(117A, 118A, 126A, 127A)

1.5 pair hinges (Hager BB1279)

- 1 mortised lockset (Corbin Russwin ML2010-NSF)
- 1 closer (Corbin Russwin DC3200-689)
- 1 floor stop (Rockwood 443)
- 1 kickplate (Rockwood K1050 - 8" x 34")

Hardware Set 3

(121A)

1.5 pair hinges (Hager BB1279)

- 1 lockset (Corbin Russwin ML2057-NSF)
- 1 wall stop (Rockwood 409)
- 1 kickplate (Rockwood K1050 - 8" x 34")

Hardware Set 4

(122A, 123A)

1.5 pair hinges (Hager BB1279)

- 1 mortised lockset (Corbin Russwin ML2055-NSF)
- 1 wall stop (Rockwood 409)

Hardware Set 5

(128A, 129A)

1.5 pair hinges (Hager BB1279)

- 1 exit device (Corbin Russwin ED5200-08-NSF)
- 1 closer (Corbin Russwin DC-3200-689)
- 1 wall stop (Rockwood 409)

Hardware Set 6

(128B, 129B)

3 pair hinges (Hager BB1279)

- 2 exit device (Corbin Russwin ED5800-08-NSF)
- 2 closers (Corbin Russwin DC-3200-689)

Hardware Set 7

(130B)

1.5 pair hinges (Hager BB1279)

- 1 exit device (Corbin Russwin ED5200-14-NSF)
- 1 closer (Corbin Russwin DC3200-LBL)
- 1 wall stop (Rockwood 409)
- 1 kickplate (Rockwood K1050 - 8" x 34")

Hardware Set 8

(130C, 130D)

1.5 pair hinges (Hager BB1279)

- 1 exit device (Corbin Russwin ED5200-08-NSF)
- 1 closer (Corbin Russwin DC3200-LBL)
- 1 wall stop (Rockwood 409)
- 1 kickplate (Rockwood K1050 - 8" x 34")

Hardware Set 9

(130A)

- 3 pair hinges (Hager BB1279)
- 2 exit devices (Corbin Russwin ED5400-08-NSF)
- 2 closers (Corbin Russwin DC3200-LBL)
- 2 kickplates (Rockwood K1050 – 8" x 34")

Hardware Set 10

(131A, 131C)

90 minute fire rated opening

- 3 pair hinges (Hager BB1279)
- 2 exit devices (Corbin Russwin (A)ED5400-14-NSF)
- 2 closers (Corbin Russwin DC3200-LBL)
- 2 wall stops (Rockwood 409)
- 2 kickplates (Rockwood K1050 – 8" x 34")

END OF SECTION 087100

SECTION 088000 - GLAZING

PART 1 - GENERAL

1.1 RELATED DOCUMENTS

- A. Drawings and general provisions of the Contract, including General and Supplementary Conditions and Division 01 Specification Sections, apply to this Section.

1.2 SUMMARY

- A. Section includes glazing for the following products and applications, including those specified in other Sections where glazing requirements are specified by reference to this Section:
 - 1. Doors.
 - 2. Storefront framing.
 - 3. Glazed entrances.
 - 4. Interior borrowed lites.
 - 5. Door lites.

1.3 DEFINITIONS

- A. Glass Manufacturers: Firms that produce primary glass, fabricated glass, or both, as defined in referenced glazing publications.
- B. Glass Thicknesses: Indicated by thickness designations in millimeters according to ASTM C 1036.
- C. Interspace: Space between lites of an insulating-glass unit.

1.4 PERFORMANCE REQUIREMENTS

- A. General: Installed glazing systems shall withstand normal thermal movement and wind and impact loads (where applicable) without failure, including loss or glass breakage attributable to the following: defective manufacture, fabrication, or installation; failure of sealants or gaskets to remain watertight and airtight; deterioration of glazing materials; or other defects in construction.
- B. Delegated Design: Design glass, including comprehensive engineering analysis according to ASTM E 1300 by a qualified professional engineer, using the following design criteria:
 - 1. Design Wind Pressures: As indicated on Drawings.
 - 2. Vertical Glazing: For glass surfaces sloped 15 degrees or less from vertical, design glass to resist design wind pressure based on glass type factors for short-duration load.
 - 3. Maximum Lateral Deflection: For glass supported on all four edges, limit center-of-glass deflection at design wind pressure to not more than 1/50 times the short-side length or 1 inch, whichever is less.
 - 4. Differential Shading: Design glass to resist thermal stresses induced by differential shading within individual glass lites.
- C. Thermal Movements: Allow for thermal movements from ambient and surface temperature changes acting on glass framing members and glazing components.

1. Temperature Change: 120 deg F, ambient; 180 deg F, material surfaces.

1.5 ACTION SUBMITTALS

- A. Product Data: For each glass product and glazing material indicated.
- B. Glazing Schedule: List glass types and thicknesses for each size opening and location. Use same designations indicated on Drawings.
- C. Delegated-Design Submittal: For glass indicated to comply with performance requirements and design criteria, including analysis data signed and sealed by the qualified professional engineer responsible for their preparation.

1.6 INFORMATIONAL SUBMITTALS

- A. Qualification Data: For installers, manufacturers of insulating-glass units with sputter-coated, low-e coatings, and glass testing agency.
- B. Product Certificates: For glass and glazing products, from manufacturer.
- C. Product Test Reports: Based on evaluation of comprehensive tests performed by a qualified testing agency, for tinted glass, coated glass, insulating glass, glazing sealants, and glazing gaskets.
 1. For glazing sealants, provide test reports based on testing current sealant formulations within previous 36-month period.
- D. Preconstruction adhesion and compatibility test report.
- E. Warranties: Sample of special warranties.

1.7 QUALITY ASSURANCE

- A. Manufacturer Qualifications for Insulating-Glass Units with Sputter-Coated, Low-E Coatings: A qualified insulating-glass manufacturer who is approved by coated-glass manufacturer.
- B. Installer Qualifications: A qualified installer with demonstrated successful experience in commercial glazing projects of similar scope.
- C. Glass Testing Agency Qualifications: A qualified independent testing agency accredited according to the NFRC CAP 1 Certification Agency Program.
- D. Sealant Testing Agency Qualifications: An independent testing agency qualified according to ASTM C 1021 to conduct the testing indicated.
- E. Source Limitations for Glass: Obtain from single source from single manufacturer for each glass type.
- F. Source Limitations for Glazing Accessories: Obtain from single source from single manufacturer for each product and installation method.
- G. Glazing Publications: Comply with published recommendations of glass product manufacturers and organizations below, unless more stringent requirements are indicated. Refer to these publications for glazing terms not otherwise defined in this Section or in referenced standards.

1. GANA Publications: GANA's "Glazing Manual."
 2. IGMA Publication for Insulating Glass: SIGMA TM-3000, "North American Glazing Guidelines for Sealed Insulating Glass Units for Commercial and Residential Use."
- H. Safety Glazing Labeling: Where safety glazing labeling is indicated, permanently mark glazing with certification label of the SGCC or another certification agency acceptable to authorities having jurisdiction. Label shall indicate manufacturer's name, type of glass, thickness, and safety glazing standard with which glass complies.
- I. Fire-Protection-Rated Glazing Labeling: Permanently mark fire-protection-rated glazing with certification label of a testing agency acceptable to authorities having jurisdiction. Label shall indicate manufacturer's name, test standard, whether glazing is for use in fire doors or other openings, whether or not glazing passes hose-stream test, whether or not glazing has a temperature rise rating of 450 deg F, and the fire-resistance rating in minutes.
- J. Insulating-Glass Certification Program: Permanently marked either on spacers or on at least one component lite of units with appropriate certification label of IGCC.
- K. Preinstallation Conference: Conduct conference at Project site.
1. Review and finalize construction schedule and verify availability of materials, Installer's personnel, equipment, and facilities needed to make progress and avoid delays.
 2. Review temporary protection requirements for glazing during and after installation.
- 1.8 DELIVERY, STORAGE, AND HANDLING
- A. Protect glazing materials according to manufacturer's written instructions. Prevent damage to glass and glazing materials from condensation, temperature changes, direct exposure to sun, or other causes.
- 1.9 PROJECT CONDITIONS
- A. Environmental Limitations: Do not proceed with glazing when ambient and substrate temperature conditions are outside limits permitted by glazing material manufacturers and when glazing channel substrates are wet from rain, frost, condensation, or other causes.
1. Do not install glazing sealants when ambient and substrate temperature conditions are outside limits permitted by sealant manufacturer or below 40 deg F.
- 1.10 WARRANTY
- A. Manufacturer's Special Warranty for Coated-Glass Products: Manufacturer's standard form in which coated-glass manufacturer agrees to replace coated-glass units that deteriorate within specified warranty period. Deterioration of coated glass is defined as defects developed from normal use that are not attributed to glass breakage or to maintaining and cleaning coated glass contrary to manufacturer's written instructions. Defects include peeling, cracking, and other indications of deterioration in coating.
1. Warranty Period: 10 years from date of Substantial Completion.

- B. Manufacturer's Special Warranty on Laminated Glass: Manufacturer's standard form in which laminated-glass manufacturer agrees to replace laminated-glass units that deteriorate within specified warranty period. Deterioration of laminated glass is defined as defects developed from normal use that are not attributed to glass breakage or to maintaining and cleaning laminated glass contrary to manufacturer's written instructions. Defects include edge separation, delamination materially obstructing vision through glass, and blemishes exceeding those allowed by referenced laminated-glass standard.
1. Warranty Period: 10 years from date of Substantial Completion.
- C. Manufacturer's Special Warranty on Insulating Glass: Manufacturer's standard form in which insulating-glass manufacturer agrees to replace insulating-glass units that deteriorate within specified warranty period. Deterioration of insulating glass is defined as failure of hermetic seal under normal use that is not attributed to glass breakage or to maintaining and cleaning insulating glass contrary to manufacturer's written instructions. Evidence of failure is the obstruction of vision by dust, moisture, or film on interior surfaces of glass.
1. Warranty Period: 10 years from date of Substantial Completion.

PART 2 - PRODUCTS

2.1 GLASS PRODUCTS, GENERAL

- A. Thickness: Where glass thickness is indicated, it is a minimum. Provide glass lites in thicknesses as needed to comply with requirements indicated.
1. Minimum Glass Thickness for Exterior Lites: Not less than 6.0 mm.
 2. Thickness of Tinted Glass: Provide same thickness for each tint color indicated throughout Project.
- B. Strength: Where float glass is indicated, provide annealed float glass, Kind HS heat-treated float glass, or Kind FT heat-treated float glass as needed to comply with "Performance Requirements" Article. Where heat-strengthened glass is indicated, provide Kind HS heat-treated float glass or Kind FT heat-treated float glass as needed to comply with "Performance Requirements" Article. Where fully tempered glass is indicated, provide Kind FT heat-treated float glass.
- C. Thermal and Optical Performance Properties: Provide glass with performance properties specified, as indicated in manufacturer's published test data, based on procedures indicated below:
1. For monolithic-glass lites, properties are based on units with lites of thickness indicated.
 2. U-Factors: Center-of-glazing values, according to NFRC 100 and based on LBL's WINDOW 5.2 computer program, expressed as Btu/sq. ft. x h x deg F.
 3. Solar Heat-Gain Coefficient and Visible Transmittance: Center-of-glazing values, according to NFRC 200 and based on LBL's WINDOW 5.2 computer program.
 4. Visible Reflectance: Center-of-glazing values, according to NFRC 300.

2.2 GLASS PRODUCTS

- A. Float Glass: ASTM C 1036, Type I, Quality-Q3, Class I (clear) unless otherwise indicated.
- B. Heat-Treated Float Glass: ASTM C 1048; Type I; Quality-Q3; Class I (clear) unless otherwise indicated; of kind and condition indicated.

1. Fabrication Process: By horizontal (roller-hearth) process with roll-wave distortion parallel to bottom edge of glass as installed unless otherwise indicated.
2. For uncoated glass, comply with requirements for Condition A.
3. For coated vision glass, comply with requirements for Condition C (other coated glass).

For a discussion of heat-soaking, see: http://www.aisglass.com/heat_strengthened.asp Coating in first paragraph below is available only on clear float glass and is applied pyrolytically on the float line. Consequently, if a reflective or low-e coating is required (which would be on the second surface, which was exposed to the molten tin bath on the float line), it must be a sputtered coating.

- C. Polished Wired Glass: ASTM C 1036, Type II, Class 1 (clear), Form 1, Quality-Q6, complying with ANSI Z97.1, Class C.
 1. Mesh: M2 (square).
- D. Reflective-Coated Vision Glass: ASTM C 1376, coated by pyrolytic process vacuum deposition (sputter-coating) process, and complying with other requirements specified.
 1. Basis-of-Design Product: Subject to compliance with requirements, provide Guardian Industries Corp., Clear with "SuperNeutral 54" low-e coating or comparable product by one of the following:
 - a. AFG Industries, Inc.
 - b. Cardinal Glass Industries
 - c. Guardian Industries Corp.
 - d. PPG
 - e. Pilkington, North America.
 2. Kind: Kind CV (coated vision glass).
 3. Glass: Clear float.

2.3 INSULATING GLASS

- A. Insulating-Glass Units: Factory-assembled units consisting of sealed lites of glass separated by a dehydrated interspace, Argon filled, qualified according to ASTM E 2190, and complying with other requirements specified.
 1. Sealing System: Dual seal, with polyisobutylene and silicone primary and secondary.
 2. Spacer: Aluminum with mill or clear anodic finish, Aluminum with bronze, color anodic finish to match window frame finish.
 3. Desiccant: Molecular sieve or silica gel, or blend of both.
 4. System Compatibility: Insulating glass fabricator shall certify that the glass and glass coatings are compatible with the spacer seals and adhesives.

2.4 GLAZING GASKETS

- A. Dense Compression Gaskets: Molded or extruded gaskets of profile and hardness required to maintain watertight seal, made from one of the following:
 1. EPDM complying with ASTM C 864.
 2. Silicone complying with ASTM C 1115.
 3. Thermoplastic polyolefin rubber complying with ASTM C 1115.

B. Soft Compression Gaskets: Extruded or molded, closed-cell, integral-skinned EPDM, silicone, or thermoplastic polyolefin rubber gaskets complying with ASTM C 509, Type II, black; of profile and hardness required to maintain watertight seal.

1. Application: Use where soft compression gaskets will be compressed by inserting dense compression gaskets on opposite side of glazing or pressure applied by means of pressure-glazing stops on opposite side of glazing.

2.5 GLAZING SEALANTS

A. General:

1. Compatibility: Provide glazing sealants that are compatible with one another and with other materials they will contact, including glass products, seals of insulating-glass units, and glazing channel substrates, under conditions of service and application, as demonstrated by sealant manufacturer based on testing and field experience.

- a. Suitability: Comply with sealant and glass manufacturers' written instructions for selecting glazing sealants suitable for applications indicated and for conditions existing at time of installation.

2. Sealants used inside the weatherproofing system, shall have a VOC content of not more than 250 g/L when calculated according to 40 CFR 59, Subpart D (EPA Method 24).
3. Colors of Exposed Glazing Sealants: As selected by Architect from manufacturer's full range.

B. Glazing Sealant: Neutral-curing silicone glazing sealant complying with ASTM C 920, Type S, Grade NS, Class 100/50, Use NT.

1. Products: Subject to compliance with requirements, provide one of the following:

- a. Dow Corning Corporation; 790.
 - b. GE Advanced Materials - Silicones; SilPruf LM SCS2700.
 - c. Pecora Corporation; 890.
 - d. Sika Corporation, Construction Products Division; SikaSil-C990.
 - e. Tremco Incorporated; Spectrem 1.

C. Glazing Sealants for Fire-Rated Glazing Products: Products that are approved by testing agencies that listed and labeled fire-resistant glazing products with which they are used for applications and fire-protection ratings indicated.

2.6 GLAZING TAPES

A. Back-Bedding Mastic Glazing Tapes: Preformed, butyl-based, 100 percent solids elastomeric tape; nonstaining and nonmigrating in contact with nonporous surfaces; with or without spacer rod as recommended in writing by tape and glass manufacturers for application indicated; and complying with ASTM C 1281 and AAMA 800 for products indicated below:

1. AAMA 806.3 tape, for glazing applications in which tape is subject to continuous pressure.
2. AAMA 807.3 tape, for glazing applications in which tape is not subject to continuous pressure.

B. Expanded Cellular Glazing Tapes: Closed-cell, PVC foam tapes; factory coated with adhesive on both surfaces; and complying with AAMA 800 for the following types:

1. AAMA 810.1, Type 1, for glazing applications in which tape acts as the primary sealant.

2. AAMA 810.1, Type 2, for glazing applications in which tape is used in combination with a full bead of liquid sealant.

2.7 MISCELLANEOUS GLAZING MATERIALS

- A. General: Provide products of material, size, and shape complying with referenced glazing standard, requirements of manufacturers of glass and other glazing materials for application indicated, and with a proven record of compatibility with surfaces contacted in installation.
- B. Cleaners, Primers, and Sealers: Types recommended by sealant or gasket manufacturer.
- C. Setting Blocks: Elastomeric material with a Shore, Type A durometer hardness of 85, plus or minus 5.
- D. Spacers: Elastomeric blocks or continuous extrusions of hardness required by glass manufacturer to maintain glass lites in place for installation indicated.
- E. Edge Blocks: Elastomeric material of hardness needed to limit glass lateral movement (side walking).
- F. Cylindrical Glazing Sealant Backing: ASTM C 1330, Type O (open-cell material), of size and density to control glazing sealant depth and otherwise produce optimum glazing sealant performance.
- G. Perimeter Insulation for Fire-Resistive Glazing: Product that is approved by testing agency that listed and labeled fire-resistant glazing product with which it is used for application and fire-protection rating indicated.

2.8 FABRICATION OF GLAZING UNITS

- A. Fabricate glazing units in sizes required to fit openings indicated for Project, with edge and face clearances, edge and surface conditions, and bite complying with written instructions of product manufacturer and referenced glazing publications, to comply with system performance requirements.
- B. Clean-cut or flat-grind vertical edges of butt-glazed monolithic lites to produce square edges with slight chamfers at junctions of edges and faces.
- C. Grind smooth and polish exposed glass edges and corners.

2.9 MONOLITHIC-GLASS TYPES

- A. Glass Type GL-1: Clear heat-strengthened float glass.
 1. Thickness: 6.0 mm.
- B. Glass Type GL-1T: Clear fully tempered float glass.
 1. Thickness: 6.0 mm.
 2. Provide safety glazing labeling.

2.10 INSULATING-GLASS TYPES

- A. Glass Type IG-1: Clear, Low-e coated, insulating glass.
 - 1. Overall Unit Thickness: 1 inch.
 - 2. Thickness of Each Glass Lite: 6.0 mm.
 - 3. Outdoor Lite: Heat-strengthened reflective-coated vision glass with low-e coating on #2 surface Fully tempered float glass.
 - 4. Interspace Content: Air.
 - 5. Indoor Lite: Heat-strengthened float glass.
 - 6. Winter Nighttime U-Factor: 0.29 maximum.
 - 7. Shading Coefficient: 0.32 maximum.
 - 8. Provide safety glazing labeling.
 - 9. Low-e coating: Second surface.

PART 3 - EXECUTION

3.1 EXAMINATION

- A. Examine framing, glazing channels, and stops, with Installer present, for compliance with the following:
 - 1. Manufacturing and installation tolerances, including those for size, squareness, and offsets at corners.
 - 2. Presence and functioning of weep systems.
 - 3. Minimum required face and edge clearances.
 - 4. Effective sealing between joints of glass-framing members.
- B. Proceed with installation only after unsatisfactory conditions have been corrected.

3.2 PREPARATION

- A. Clean glazing channels and other framing members receiving glass immediately before glazing. Remove coatings not firmly bonded to substrates.
- B. Examine glazing units to locate exterior and interior surfaces. Label or mark units as needed so that exterior and interior surfaces are readily identifiable. Do not use materials that will leave visible marks in the completed work.

3.3 GLAZING, GENERAL

- A. Comply with combined written instructions of manufacturers of glass, sealants, gaskets, and other glazing materials, unless more stringent requirements are indicated, including those in referenced glazing publications.
- B. Adjust glazing channel dimensions as required by Project conditions during installation to provide necessary bite on glass, minimum edge and face clearances, and adequate sealant thicknesses, with reasonable tolerances.

- C. Protect glass edges from damage during handling and installation. Remove damaged glass from Project site and legally dispose of off Project site. Damaged glass is glass with edge damage or other imperfections that, when installed, could weaken glass and impair performance and appearance.
- D. Apply primers to joint surfaces where required for adhesion of sealants, as determined by preconstruction testing.
- E. Install setting blocks in sill rabbets, sized and located to comply with referenced glazing publications, unless otherwise required by glass manufacturer. Set blocks in thin course of compatible sealant suitable for heel bead.
- F. Do not exceed edge pressures stipulated by glass manufacturers for installing glass lites.
- G. Provide spacers for glass lites where length plus width is larger than 50 inches.
 - 1. Locate spacers directly opposite each other on both inside and outside faces of glass. Install correct size and spacing to preserve required face clearances, unless gaskets and glazing tapes are used that have demonstrated ability to maintain required face clearances and to comply with system performance requirements.
 - 2. Provide 1/8-inch minimum bite of spacers on glass and use thickness equal to sealant width. With glazing tape, use thickness slightly less than final compressed thickness of tape.
- H. Provide edge blocking where indicated or needed to prevent glass lites from moving sideways in glazing channel, as recommended in writing by glass manufacturer and according to requirements in referenced glazing publications.
- I. Set glass lites in each series with uniform pattern, draw, bow, and similar characteristics.
- J. Set glass lites with proper orientation so that coatings face exterior or interior as specified.
- K. Where wedge-shaped gaskets are driven into one side of channel to pressurize sealant or gasket on opposite side, provide adequate anchorage so gasket cannot walk out when installation is subjected to movement.
- L. Square cut wedge-shaped gaskets at corners and install gaskets in a manner recommended by gasket manufacturer to prevent corners from pulling away; seal corner joints and butt joints with sealant recommended by gasket manufacturer.

3.4 TAPE GLAZING

- A. Position tapes on fixed stops so that, when compressed by glass, their exposed edges are flush with or protrude slightly above sightline of stops.
- B. Install tapes continuously, but not necessarily in one continuous length. Do not stretch tapes to make them fit opening.
- C. Cover vertical framing joints by applying tapes to heads and sills first and then to jambs. Cover horizontal framing joints by applying tapes to jambs and then to heads and sills.
- D. Place joints in tapes at corners of opening with adjoining lengths butted together, not lapped. Seal joints in tapes with compatible sealant approved by tape manufacturer.
- E. Do not remove release paper from tape until right before each glazing unit is installed.
- F. Apply heel bead of elastomeric sealant where indicated

- G. Center glass lites in openings on setting blocks and press firmly against tape by inserting dense compression gaskets formed and installed to lock in place against faces of removable stops. Start gasket applications at corners and work toward centers of openings.

3.5 GASKET GLAZING (DRY)

- A. Cut compression gaskets to lengths recommended by gasket manufacturer to fit openings exactly, with allowance for stretch during installation.
- B. Insert soft compression gasket between glass and frame or fixed stop so it is securely in place with joints miter cut and bonded together at corners.
- C. Installation with Drive-in Wedge Gaskets: Center glass lites in openings on setting blocks and press firmly against soft compression gasket by inserting dense compression gaskets formed and installed to lock in place against faces of removable stops. Start gasket applications at corners and work toward centers of openings. Compress gaskets to produce a weathertight seal without developing bending stresses in glass. Seal gasket joints with sealant recommended by gasket manufacturer.
- D. Installation with Pressure-Glazing Stops: Center glass lites in openings on setting blocks and press firmly against soft compression gasket. Install dense compression gaskets and pressure-glazing stops, applying pressure uniformly to compression gaskets. Compress gaskets to produce a weathertight seal without developing bending stresses in glass. Seal gasket joints with sealant recommended by gasket manufacturer.
- E. Install gaskets so they protrude past face of glazing stops.

3.6 CLEANING AND PROTECTION

- A. Protect exterior glass from damage immediately after installation by attaching crossed streamers to framing held away from glass. Do not apply markers to glass surface. Remove nonpermanent labels and clean surfaces.
- B. Protect glass from contact with contaminating substances resulting from construction operations. If, despite such protection, contaminating substances do come into contact with glass, remove substances immediately as recommended in writing by glass manufacturer.
- C. Examine glass surfaces adjacent to or below exterior concrete and other masonry surfaces at frequent intervals during construction, but not less than once a month, for buildup of dirt, scum, alkaline deposits, or stains; remove as recommended in writing by glass manufacturer.
- D. Remove and replace glass that is broken, chipped, cracked, or abraded or that is damaged from natural causes, accidents, and vandalism, during construction period.
- E. Wash glass on both exposed surfaces in each area of Project not more than four days before date scheduled for inspections that establish date of Substantial Completion. Wash glass as recommended in writing by glass manufacturer.

END OF SECTION 088000

SECTION 092216 - NON-STRUCTURAL METAL FRAMING

PART 1 - GENERAL

1.1 RELATED DOCUMENTS

- A. Drawings and general provisions of the Contract, including General and Supplementary Conditions and Division 01 Specification Sections, apply to this Section.

1.2 SUMMARY

- A. Section Includes:
 - 1. Non-load-bearing steel framing systems for interior gypsum board assemblies.
 - 2. Suspension systems for interior gypsum ceilings, soffits, and grid systems.

1.3 ACTION SUBMITTALS

- A. Product Data: For each type of product.

1.4 INFORMATION SUBMITTALS

- A. Evaluation Reports: For dimpled steel studs and runners firestop tracks, from ICC-ES.

PART 2 - PRODUCTS

2.1 DESCRIPTION

- A. Fire-Test-Response Characteristics: For fire-resistance-rated assemblies that incorporate non-load-bearing steel framing, provide materials and construction identical to those tested in assembly indicated according to ASTM E 119 by an independent testing agency.
- B. STC-Rated Assemblies: For STC-rated assemblies, provide materials and construction identical to those tested in assembly indicated according to ASTM E 90 and classified according to ASTM E 413 by an independent testing agency.

2.2 FRAMING SYSTEMS

- A. Framing Members, General: Comply with ASTM C 754 for conditions indicated.
 - 1. Steel Sheet Components: Comply with ASTM C 645 requirements for metal unless otherwise indicated.
 - 2. Protective Coating: Coating with equivalent corrosion resistance of ASTM A 653/A 653M, G40, hot-dip galvanized, unless otherwise indicated.
- B. Studs and Runners: ASTM C 645. Use either steel studs and runners or dimpled steel studs and runners.

1. Steel Studs and Runners:
 - a. Minimum Base-Metal Thickness: 0.018 inch.
 - b. Depth: As indicated on Drawings.
 2. Dimpled Steel Studs and Runners:
 - a. Minimum Base-Metal Thickness: 0.015 inch.
 - b. Depth: As indicated on Drawings.
- C. Slip-Type Head Joints: Where indicated, provide one of the following:
1. Double-Runner System: ASTM C 645 top runners, inside runner with 2-inch- deep flanges in thickness not less than indicated for studs and fastened to studs, and outer runner sized to friction fit inside runner.
 2. Deflection Track: Steel sheet top runner manufactured to prevent cracking of finishes applied to interior partition framing resulting from deflection of structure above; in thickness not less than indicated for studs and in width to accommodate depth of studs.
 - a. Products: Subject to compliance with requirements, available products that may be incorporated into the Work include, but are not limited to, the following:
 - 1) Dietrich Metal Framing; SLP-TRK Slotted Deflection Track.
 - 2) Steel Network Inc. (The); VertiClip SLD, VertiTrack VTD Series.
- D. Firestop Tracks: Top runner manufactured to allow partition heads to expand and contract with movement of the structure while maintaining continuity of fire-resistance-rated assembly indicated; in thickness not less than indicated for studs and in width to accommodate depth of studs.
1. Products: Subject to compliance with requirements, available products that may be incorporated into the Work include, but are not limited to, the following:
 - a. Fire Trak Corp.; Fire Trak System attached to studs with Fire Trak Posi Klip.
 - b. Grace Construction Products; FlameSafe FlowTrak System.
- E. Flat Strap and Backing Plate: Steel sheet for blocking and bracing in length and width indicated.
1. Minimum Base-Metal Thickness: 0.018 inch .
- F. Cold-Rolled Channel Bridging: Steel, 0.053-inch minimum base-metal thickness, with minimum 1/2-inch- wide flanges.
1. Depth: 1-1/2 inches.
 2. Clip Angle: Not less than 1-1/2 by 1-1/2 inches, 0.068-inch- thick, galvanized steel.
- G. Hat-Shaped, Rigid Furring Channels: ASTM C 645.
1. Minimum Base-Metal Thickness: 0.018 inch .
 2. Depth: 7/8 inch.
- H. Resilient Furring Channels: 1/2-inch- deep, steel sheet members designed to reduce sound transmission.
1. Configuration: Asymmetrical.
- I. Cold-Rolled Furring Channels: 0.053-inch uncoated-steel thickness, with minimum 1/2-inch- wide flanges.

1. Depth: As indicated on Drawings.
 2. Furring Brackets: Adjustable, corrugated-edge type of steel sheet with minimum uncoated-steel thickness of 0.033 inch.
 3. Tie Wire: ASTM A 641/A 641M, Class 1 zinc coating, soft temper, 0.062-inch- diameter wire, or double strand of 0.048-inch- diameter wire.
- J. Z-Shaped Furring: With slotted or nonslotted web, face flange of 1-1/4 inches, wall attachment flange of 7/8 inch, minimum uncoated-metal thickness of 0.018 inch, and depth required to fit insulation thickness indicated.

2.3 SUSPENSION SYSTEMS

- A. Tie Wire: ASTM A 641/A 641M, Class 1 zinc coating, soft temper, 0.062-inch- diameter wire, or double strand of 0.048-inch- diameter wire.
- B. Wire Hangers: ASTM A 641/A 641M, Class 1 zinc coating, soft temper, 0.16 inch in diameter.
- C. Flat Hangers: Steel sheet, 1 by 3/16 inch by length indicated.
- D. Carrying Channels: Cold-rolled, commercial-steel sheet with a base-metal thickness of 0.053 inch and minimum 1/2-inch- wide flanges.
1. Depth: 2-1/2 inches.
- E. Furring Channels (Furring Members):
1. Steel Studs and Runners: ASTM C 645.
 - a. Minimum Base-Metal Thickness: 0.018 inch.
 - b. Depth: As indicated on Drawings.
 2. Dimpled Steel Studs and Runners: ASTM C 645.
 - a. Minimum Base-Metal Thickness: 0.015 inch.
 - b. Depth: As indicated on Drawings.
 3. Resilient Furring Channels: 1/2-inch- deep members designed to reduce sound transmission.
 - a. Configuration: Asymmetrical.
- F. Grid Suspension System for Gypsum Board Ceilings: ASTM C 645, direct-hung system composed of main beams and cross-furring members that interlock.
1. Products: Subject to compliance with requirements, provide one of the following:
 - a. Armstrong World Industries, Inc.; Drywall Grid Systems.
 - b. Chicago Metallic Corporation; Drywall Grid System.
 - c. USG Corporation; Drywall Suspension System.

2.4 AUXILIARY MATERIALS

- A. General: Provide auxiliary materials that comply with referenced installation standards.
1. Fasteners for Metal Framing: Of type, material, size, corrosion resistance, holding power, and other properties required to fasten steel members to substrates.

- B. Isolation Strip at Exterior Walls: Provide one of the following:
 - 1. Foam Gasket: Adhesive-backed, closed-cell vinyl foam strips that allow fastener penetration without foam displacement, 1/8 inch thick, in width to suit steel stud size.

PART 3 - EXECUTION

3.1 EXAMINATION

- A. Examine areas and substrates, with Installer present, and including welded hollow-metal frames, cast-in anchors, and structural framing, for compliance with requirements and other conditions affecting performance of the Work.
- B. Proceed with installation only after unsatisfactory conditions have been corrected.

3.2 PREPARATION

- A. Suspended Assemblies: Coordinate installation of suspension systems with installation of overhead structure to ensure that inserts and other provisions for anchorages to building structure have been installed to receive hangers at spacing required to support the Work and that hangers will develop their full strength.
- B. Coordination with Sprayed Fire-Resistive Materials:
 - 1. Before sprayed fire-resistive materials are applied, attach offset anchor plates or ceiling runners (tracks) to surfaces indicated to receive sprayed fire-resistive materials. Where offset anchor plates are required, provide continuous plates fastened to building structure not more than 24 inches o.c.
 - 2. After sprayed fire-resistive materials are applied, remove them only to extent necessary for installation of non-load-bearing steel framing. Do not reduce thickness of fire-resistive materials below that required for fire-resistance ratings indicated. Protect adjacent fire-resistive materials from damage.

3.3 INSTALLATION, GENERAL

- A. Installation Standard: ASTM C 754, except comply with framing sizes and spacing indicated.
 - 1. Gypsum Plaster Assemblies: Also comply with requirements in ASTM C 841 that apply to framing installation.
 - 2. Portland Cement Plaster Assemblies: Also comply with requirements in ASTM C 1063 that apply to framing installation.
 - 3. Gypsum Veneer Plaster Assemblies: Also comply with requirements in ASTM C 844 that apply to framing installation.
 - 4. Gypsum Board Assemblies: Also comply with requirements in ASTM C 840 that apply to framing installation.
- B. Install supplementary framing, and blocking to support fixtures, equipment services, heavy trim, grab bars, toilet accessories, furnishings, or similar construction.
- C. Install bracing at terminations in assemblies.
- D. Do not bridge building control and expansion joints with non-load-bearing steel framing members. Frame both sides of joints independently.

3.4 INSTALLING FRAMED ASSEMBLIES

- A. Where studs are installed directly against exterior masonry walls or dissimilar metals at exterior walls, install isolation strip between studs and exterior wall.
- B. Install studs so flanges within framing system point in same direction.
- C. Install tracks (runners) at floors and overhead supports. Extend framing full height to structural supports or substrates above suspended ceilings, except where partitions are indicated to terminate at suspended ceilings. Continue framing around ducts penetrating partitions above ceiling.
 - 1. Slip-Type Head Joints: Where framing extends to overhead structural supports, install to produce joints at tops of framing systems that prevent axial loading of finished assemblies.
 - 2. Door Openings: Screw vertical studs at jambs to jamb anchor clips on door frames; install runner track section (for cripple studs) at head and secure to jamb studs.
 - a. Install two studs at each jamb unless otherwise indicated.
 - b. Extend jamb studs through suspended ceilings and attach to underside of overhead structure.
 - 3. Other Framed Openings: Frame openings other than door openings the same as required for door openings unless otherwise indicated. Install framing below sills of openings to match framing required above door heads.
 - 4. Fire-Resistance-Rated Partitions: Install framing to comply with fire-resistance-rated assembly indicated and support closures and to make partitions continuous from floor to underside of solid structure.
 - a. Firestop Track: Where indicated, install to maintain continuity of fire-resistance-rated assembly indicated.
 - 5. Sound-Rated Partitions: Install framing to comply with sound-rated assembly indicated.
 - 6. Curved Partitions:
 - a. Bend track to uniform curve and locate straight lengths so they are tangent to arcs.
 - b. Begin and end each arc with a stud, and space intermediate studs equally along arcs. On straight lengths of no fewer than two studs at ends of arcs, place studs 6 inches o.c.
- D. Direct Furring:
 - 1. Screw to wood framing.
 - 2. Attach to concrete or masonry with stub nails, screws designed for masonry attachment, or powder-driven fasteners spaced 24 inches o.c.
- E. Z-Furring Members:
 - 1. Erect insulation (specified in Division 07 Section "Thermal Insulation") vertically and hold in place with Z-furring members spaced 24 inches o.c.
- F. Installation Tolerance: Install each framing member so fastening surfaces vary not more than 1/8 inch from the plane formed by faces of adjacent framing.

3.5 INSTALLING SUSPENSION SYSTEMS

- A. Install suspension system components in sizes and spacings indicated on Drawings, but not less than those required by referenced installation standards for assembly types and other assembly components indicated.

- B. Isolate suspension systems from building structure where they abut or are penetrated by building structure to prevent transfer of loading imposed by structural movement.
- C. Suspend hangers from building structure as follows:
 - 1. Install hangers plumb and free from contact with insulation or other objects within ceiling plenum that are not part of supporting structural or suspension system.
 - a. Splay hangers only where required to miss obstructions and offset resulting horizontal forces by bracing, countersplaying, or other equally effective means.
 - 2. Where width of ducts and other construction within ceiling plenum produces hanger spacings that interfere with locations of hangers required to support standard suspension system members, install supplemental suspension members and hangers in the form of trapezes or equivalent devices.
 - a. Size supplemental suspension members and hangers to support ceiling loads within performance limits established by referenced installation standards.
 - 3. Wire Hangers: Secure by looping and wire tying, either directly to structures or to inserts, eye screws, or other devices and fasteners that are secure and appropriate for substrate, and in a manner that will not cause hangers to deteriorate or otherwise fail.
 - 4. Do not attach hangers to steel roof deck.
 - 5. Do not attach hangers to permanent metal forms. Furnish cast-in-place hanger inserts that extend through forms.
 - 6. Do not attach hangers to rolled-in hanger tabs of composite steel floor deck.
 - 7. Do not connect or suspend steel framing from ducts, pipes, or conduit.
- D. Fire-Resistance-Rated Assemblies: Wire tie furring channels to supports.
- E. Seismic Bracing: Sway-brace suspension systems with hangers used for support.
- F. Grid Suspension Systems: Attach perimeter wall track or angle where grid suspension systems meet vertical surfaces. Mechanically join main beam and cross-furring members to each other and butt-cut to fit into wall track.
- G. Installation Tolerances: Install suspension systems that are level to within 1/8 inch in 12 feet measured lengthwise on each member that will receive finishes and transversely between parallel members that will receive finishes.

END OF SECTION 092216

SECTION 092900 - GYPSUM BOARD

PART 1 - GENERAL

1.1 RELATED DOCUMENTS

- A. Drawings and general provisions of the Contract, including General and Supplementary Conditions and Division 01 Specification Sections, apply to this Section.

1.2 SUMMARY

- A. Section Includes:
 - 1. Interior gypsum board.
 - 2. Exterior gypsum board for ceilings and soffits.

1.3 ACTION SUBMITTALS

- A. Product Data: For each type of product.

1.4 DELIVERY, STORAGE AND HANDLING

- A. Store materials inside under cover and keep them dry and protected against weather, condensation, direct sunlight, construction traffic, and other potential causes of damage. Stack panels flat and supported on risers on a flat platform to prevent sagging.

1.5 FIELD CONDITIONS

- A. Environmental Limitations: Comply with ASTM C 840 requirements or gypsum board manufacturer's written recommendations, whichever are more stringent.
- B. Do not install paper-faced gypsum panels until installation areas are enclosed and conditioned.
- C. Do not install panels that are wet, those that are moisture damaged, and those that are mold damaged.
 - 1. Indications that panels are wet or moisture damaged include, but are not limited to, discoloration, sagging, or irregular shape.
 - 2. Indications that panels are mold damaged include, but are not limited to, fuzzy or splotchy surface contamination and discoloration.

PART 2 - PRODUCTS

2.1 PERFORMANCE REQUIREMENTS

- A. Fire-Resistance-Rated Assemblies: For fire-resistance-rated assemblies, provide materials and construction identical to those tested in assembly indicated according to ASTM E 119 by an independent testing agency.

- B. STC-Rated Assemblies: For STC-rated assemblies, provide materials and construction identical to those tested in assembly indicated according to ASTM E 90 and classified according to ASTM E 413 by an independent testing agency.

2.2 GYPSUM BOARD, GENERAL

- A. Size: Provide maximum lengths and widths available that will minimize joints in each area and that correspond with support system indicated.

2.3 INTERIOR GYPSUM BOARD

- A. Manufacturers: Subject to compliance with requirements, provide products by one of the following:
 - 1. American Gypsum.
 - 2. Georgia-Pacific Gypsum LLC.
 - 3. National Gypsum Company.
 - 4. Temple-Inland.
 - 5. USG Corporation.
- B. Gypsum Wallboard: ASTM C 1396/C 1396M.
 - 1. Thickness: 5/8 inch.
 - 2. Long Edges: Tapered.
- C. Gypsum Board, Type X: ASTM C 1396/C 1396M.
 - 1. Thickness: 5/8 inch.
 - 2. Long Edges: Tapered.
- D. Gypsum Ceiling Board: ASTM C 1396/C 1396M.
 - 1. Thickness: 1/2 inch.
 - 2. Long Edges: Tapered.
- E. Moisture- and Mold-Resistant Gypsum Board: ASTM C 1396/C 1396M. With moisture- and mold-resistant core and paper surfaces.
 - 1. Core: 5/8 inch, Type X.
 - 2. Long Edges: Tapered.
 - 3. Mold Resistance: ASTM D 3273, score of 10.

2.4 TRIM ACCESSORIES

- A. Interior Trim: ASTM C 1047.
 - 1. Material: Galvanized or aluminum-coated steel sheet or rolled zinc.
 - 2. Shapes:
 - a. Cornerbead.
 - b. LC-Bead: J-shaped; exposed long flange receives joint compound.
 - c. L-Bead: L-shaped; exposed long flange receives joint compound.
 - d. Expansion (control) joint.
- B. Exterior Trim: ASTM C 1047.

1. Material: Hot-dip galvanized steel sheet, plastic, or rolled zinc.
 2. Shapes:
 - a. Cornerbead.
 - b. LC-Bead: J-shaped; exposed long flange receives joint compound.
 - c. Expansion (Control) Joint: One-piece, rolled zinc with V-shaped slot and removable strip covering slot opening.
- C. Aluminum Trim: Extruded accessories of profiles and dimensions indicated.
1. Manufacturers: Subject to compliance with requirements, provide products by the following:
 - a. Fry Reglet Corp.
 - b. Gordon, Inc.
 - c. Pittcon Industries.
 2. Aluminum: Alloy and temper with not less than the strength and durability properties of ASTM B 221, Alloy 6063-T5.
 3. Finish: Corrosion-resistant primer compatible with joint compound and finish materials specified.

2.5 JOINT TREATMENT MATERIALS

- A. General: Comply with ASTM C 475/C 475M.
- B. Joint Tape:
1. Interior Gypsum Board: Paper.
 2. Exterior Gypsum Soffit Board: Paper.
 3. Glass-Mat Gypsum Sheathing Board: 10-by-10 glass mesh.
 4. Tile Backing Panels: As recommended by panel manufacturer.
- C. Joint Compound for Interior Gypsum Board: For each coat use formulation that is compatible with other compounds applied on previous or for successive coats.
1. Prefilling: At open joints, rounded or beveled panel edges, and damaged surface areas, use setting-type taping compound.
 2. Embedding and First Coat: For embedding tape and first coat on joints, fasteners, and trim flanges, use setting-type taping compound.
 - a. Use setting-type compound for installing paper-faced metal trim accessories.
 3. Fill Coat: For second coat, use drying-type, all-purpose compound.
 4. Finish Coat: For third coat, use drying-type, all-purpose compound.
- D. Joint Compound for Exterior Applications:
1. Exterior Gypsum Soffit Board: Use setting-type taping compound and setting-type, sandable topping compound.
 2. Glass-Mat Gypsum Sheathing Board: As recommended by sheathing board manufacturer.

2.6 AUXILIARY MATERIALS

- A. General: Provide auxiliary materials that comply with referenced installation standards and manufacturer's written recommendations.
- B. Laminating Adhesive: Adhesive or joint compound recommended for directly adhering gypsum panels to continuous substrate.
 - 1. Laminating adhesive shall have a VOC content of 50 g/L or less when calculated according to 40 CFR 59, Subpart D (EPA Method 24).
- C. Steel Drill Screws: ASTM C 1002, unless otherwise indicated.
 - 1. Use screws complying with ASTM C 954 for fastening panels to steel members from 0.033 to 0.112 inch thick.
 - 2. For fastening cementitious backer units, use screws of type and size recommended by panel manufacturer.
- D. Sound Attenuation Blankets: ASTM C 665, Type I (blankets without membrane facing) produced by combining thermosetting resins with mineral fibers manufactured from glass, slag wool, or rock wool.
 - 1. Fire-Resistance-Rated Assemblies: Comply with mineral-fiber requirements of assembly.
 - 2. Recycled Content of Blankets: Postconsumer recycled content plus one-half of preconsumer recycled content not less than percent.
- E. Acoustical Joint Sealant: Manufacturer's standard nonsag, paintable, nonstaining latex sealant complying with ASTM C 834. Product effectively reduces airborne sound transmission through perimeter joints and openings in building construction as demonstrated by testing representative assemblies according to ASTM E 90.
 - 1. Acoustical joint sealant shall have a VOC content of 250 g/L or less when calculated according to 40 CFR 59, Subpart D (EPA Method 24).
- F. Thermal Insulation: As specified in Division 07 Section "Thermal Insulation."

PART 3 - EXECUTION

3.1 EXAMINATION

- A. Examine areas and substrates including welded hollow-metal frames and framing, with Installer present, for compliance with requirements and other conditions affecting performance.
- B. Examine panels before installation. Reject panels that are wet, moisture damaged, and mold damaged.
- C. Proceed with installation only after unsatisfactory conditions have been corrected.

3.2 APPLYING AND FINISHING PANELS, GENERAL

- A. Comply with ASTM C 840.
- B. Install ceiling panels across framing to minimize the number of abutting end joints and to avoid abutting end joints in central area of each ceiling. Stagger abutting end joints of adjacent panels not less than one framing member.

- C. Install panels with face side out. Butt panels together for a light contact at edges and ends with not more than 1/16 inch of open space between panels. Do not force into place.
- D. Locate edge and end joints over supports, except in ceiling applications where intermediate supports or gypsum board back-blocking is provided behind end joints. Do not place tapered edges against cut edges or ends. Stagger vertical joints on opposite sides of partitions. Do not make joints other than control joints at corners of framed openings.
- E. Form control and expansion joints with space between edges of adjoining gypsum panels.
- F. Cover both faces of support framing with gypsum panels in concealed spaces (above ceilings, etc.), except in chases braced internally.
 - 1. Unless concealed application is indicated or required for sound, fire, air, or smoke ratings, coverage may be accomplished with scraps of not less than 8 sq. ft. in area.
 - 2. Fit gypsum panels around ducts, pipes, and conduits.
 - 3. Where partitions intersect structural members projecting below underside of floor/roof slabs and decks, cut gypsum panels to fit profile formed by structural members; allow 1/4- to 3/8-inch- wide joints to install sealant.
- G. Isolate perimeter of gypsum board applied to non-load-bearing partitions at structural abutments, except floors. Provide 1/4- to 1/2-inch- wide spaces at these locations and trim edges with edge trim where edges of panels are exposed. Seal joints between edges and abutting structural surfaces with acoustical sealant.
- H. Attachment to Steel Framing: Attach panels so leading edge or end of each panel is attached to open (unsupported) edges of stud flanges first.
- I. STC-Rated Assemblies: Seal construction at perimeters, behind control joints, and at openings and penetrations with a continuous bead of acoustical sealant. Install acoustical sealant at both faces of partitions at perimeters and through penetrations. Comply with ASTM C 919 and with manufacturer's written recommendations for locating edge trim and closing off sound-flanking paths around or through assemblies, including sealing partitions above acoustical ceilings.
- J. Install sound attenuation blankets before installing gypsum panels unless blankets are readily installed after panels have been installed on one side.

3.3 APPLYING INTERIOR GYPSUM BOARD

- A. Install interior gypsum board in the following locations:
 - 1. Wallboard Type: Vertical surfaces unless otherwise indicated.
 - 2. Type X: Where required for fire-resistance-rated assembly.
 - 3. Ceiling Type: Ceiling surfaces.
 - 4. Moisture- and Mold-Resistant Type: food preparation areas, shower rooms, toilet rooms, and behind sinks.
- B. Single-Layer Application:
 - 1. On ceilings, apply gypsum panels before wall/partition board application to greatest extent possible and at right angles to framing unless otherwise indicated.
 - 2. On partitions/walls, apply gypsum panels vertically (parallel to framing) unless otherwise indicated or required by fire-resistance-rated assembly, and minimize end joints.
 - a. Stagger abutting end joints not less than one framing member in alternate courses of panels.
 - b. At stairwells and other high walls, install panels horizontally unless otherwise indicated or required by fire-resistance-rated assembly.

3. On Z-furring members, apply gypsum panels vertically (parallel to framing) with no end joints. Locate edge joints over furring members.
4. Fastening Methods: Apply gypsum panels to supports with steel drill screws.

C. Multilayer Application:

1. On ceilings, apply gypsum board indicated for base layers before applying base layers on walls/partitions; apply face layers in same sequence. Apply base layers at right angles to framing members and offset face-layer joints one framing member, 16 inches minimum, from parallel base-layer joints, unless otherwise indicated or required by fire-resistance-rated assembly.
2. On partitions/walls, apply gypsum board indicated for base layers and face layers vertically (parallel to framing) with joints of base layers located over stud or furring member and face-layer joints offset at least one stud or furring member with base-layer joints, unless otherwise indicated or required by fire-resistance-rated assembly. Stagger joints on opposite sides of partitions.
3. On Z-furring members, apply base layer vertically (parallel to framing) and face layer either vertically (parallel to framing) or horizontally (perpendicular to framing) with vertical joints offset at least one furring member. Locate edge joints of base layer over furring members.
4. Fastening Methods: Fasten base layers with screws; fasten face layers with adhesive and supplementary fasteners.

- D. Laminating to Substrate: Where gypsum panels are indicated as directly adhered to a substrate (other than studs, joists, furring members, or base layer of gypsum board), comply with gypsum board manufacturer's written recommendations and temporarily brace or fasten gypsum panels until fastening adhesive has set.

3.4 APPLYING EXTERIOR GYPSUM PANELS FOR CEILINGS AND SOFFITS

- A. Apply panels perpendicular to supports, with end joints staggered and located over supports.
1. Install with 1/4-inch open space where panels abut other construction or structural penetrations.
 2. Fasten with corrosion-resistant screws.

3.5 APPLYING TILE BACKING PANELS

- A. Cementitious Backer Units: ANSI A108.11, at locations indicated to receive tile.
- B. Where tile backing panels abut other types of panels in same plane, shim surfaces to produce a uniform plane across panel surfaces.

3.6 INSTALLING TRIM ACCESSORIES

- A. General: For trim with back flanges intended for fasteners, attach to framing with same fasteners used for panels. Otherwise, attach trim according to manufacturer's written instructions.
- B. Control Joints: Install control joints according to ASTM C 840 and in specific locations approved by Architect for visual effect.
- C. Interior Trim: Install in the following locations:
1. Cornerbead: Use at outside corners.
 2. LC-Bead: Use at exposed panel edges.

3. L-Bead: Use where indicated.
4. F-Bead: Use where indicated
- 5.

D. Exterior Trim: Install in the following locations:

1. Cornerbead: Use at outside corners.
2. LC-Bead: Use at exposed panel edges.

E. Aluminum Trim: Install in locations indicated on Drawings.

3.7 FINISHING GYPSUM BOARD

- A. General: Treat gypsum board joints, interior angles, edge trim, control joints, penetrations, fastener heads, surface defects, and elsewhere as required to prepare gypsum board surfaces for decoration. Promptly remove residual joint compound from adjacent surfaces.
- B. Prefill open joints, rounded or beveled edges, and damaged surface areas.
- C. Apply joint tape over gypsum board joints, except for trim products specifically indicated as not intended to receive tape.
- D. Gypsum Board Finish Levels: Finish panels to levels indicated below and according to ASTM C 840:
 1. Level 1: Ceiling plenum areas, concealed areas, and where indicated.
 2. Level 4: At panel surfaces that will be exposed to view unless otherwise indicated.

3.8 PROTECTION

- A. Protect adjacent surfaces from drywall compound and promptly remove from floors and other non-drywall surfaces. Repair surfaces stained, marred, or otherwise damaged during drywall application.
- B. Protect installed products from damage from weather, condensation, direct sunlight, construction, and other causes during remainder of the construction period.
- C. Remove and replace panels that are wet, moisture damaged, and mold damaged.
 1. Indications that panels are wet or moisture damaged include, but are not limited to, discoloration, sagging, or irregular shape.
 2. Indications that panels are mold damaged include, but are not limited to, fuzzy or splotchy surface contamination and discoloration.

END OF SECTION 092900

SECTION 093000 - TILING

PART 1 - GENERAL

1.1 RELATED DOCUMENTS

- A. Drawings and general provisions of the Contract, including General and Supplementary Conditions and Division 01 Specification Sections, apply to this Section.

1.2 SUMMARY

- A. Section Includes:
 - 1. Ceramic tile.
 - 2. Porcelain tile.
 - 3. Tile backing panels.
 - 4. Metal edge strips.

1.3 DEFINITIONS

- A. General: Definitions in the ANSI A108 series of tile installation standards and in ANSI A137.1 apply to Work of this Section unless otherwise specified.
- B. Module Size: Actual tile size plus joint width indicated.
- C. Face Size: Actual tile size, excluding spacer lugs.

1.4 PERFORMANCE REQUIREMENTS

- A. Static Coefficient of Friction: For tile installed on walkway surfaces, provide products with the following values as determined by testing identical products per ASTM C 1028:
 - 1. Level Surfaces: Minimum 0.6 static coefficient of friction.

1.5 ACTION SUBMITTALS

- A. Product Data: For each type of product indicated.
- B. Shop Drawings: Show locations of each type of tile and tile pattern. Show widths, details, and locations of expansion, contraction, control, and isolation joints in tile substrates and finished tile surfaces.
- C. Samples for Verification:
 - 1. Full-size units of each type and composition of tile and for each color and finish required.
 - 2. Full-size units of each type of trim and accessory for each color and finish required.
 - 3. Metal edge strips in 6-inch lengths.
 - 4. Grout color samples.

1.6 INFORMATIONAL SUBMITTALS

- A. Qualification Data: For qualified Installer.
- B. Master Grade Certificates: For each shipment, type, and composition of tile, signed by tile manufacturer and Installer.
- C. Product Certificates: For each type of product, signed by product manufacturer.
- D. Material Test Reports: For each tile-setting and -grouting product[and special purpose tile].

1.7 MAINTENANCE MATERIAL SUBMITTALS

- A. Furnish extra materials that match and are from same production runs as products installed and that are packaged with protective covering for storage and identified with labels describing contents.
 - 1. Tile and Trim Units: Furnish quantity of full-size units equal to 3 percent of amount installed for each type, composition, color, pattern, and size indicated.
 - 2. Grout: Furnish quantity of grout equal to 3 percent of amount installed for each type, composition, and color indicated.

1.8 QUALITY ASSURANCE

- A. Source Limitations for Tile: Obtain tile of each type and color or finish from one source or producer.
 - 1. Obtain tile of each type and color or finish from same production run and of consistent quality in appearance and physical properties for each contiguous area.
- B. Source Limitations for Setting and Grouting Materials: Obtain ingredients of a uniform quality for each mortar, adhesive, and grout component from one manufacturer and each aggregate from one source or producer.
- C. Source Limitations for Other Products: Obtain each of the following products specified in this Section from a single manufacturer for each product:
 - 1. Joint sealants.
 - 2. Cementitious backer units.
 - 3. Metal edge strips.

1.9 DELIVERY, STORAGE, AND HANDLING

- A. Deliver and store packaged materials in original containers with seals unbroken and labels intact until time of use. Comply with requirements in ANSI A137.1 for labeling tile packages.
- B. Store tile and cementitious materials on elevated platforms, under cover, and in a dry location.
- C. Store aggregates where grading and other required characteristics can be maintained and contamination can be avoided.
- D. Store liquid materials in unopened containers and protected from freezing.

1.10 PROJECT CONDITIONS

- A. Environmental Limitations: Do not install tile until construction in spaces is complete and ambient temperature and humidity conditions are maintained at the levels indicated in referenced standards and manufacturer's written instructions.
- B. Protect adjacent surfaces during progress of this work.

PART 2 - PRODUCTS

2.1 PRODUCTS, GENERAL

- A. ANSI Ceramic Tile Standard: Provide tile that complies with ANSI A137.1 for types, compositions, and other characteristics indicated.
 - 1. Provide tile complying with Standard grade requirements unless otherwise indicated.
- B. ANSI Standards for Tile Installation Materials: Provide materials complying with ANSI A108.02, ANSI standards referenced in other Part 2 articles, ANSI standards referenced by TCA installation methods specified in tile installation schedules, and other requirements specified.

2.2 TILE PRODUCTS

- A. Indicated on Drawings.
- B. Tile Type PP-1: glazed porcelain tile.
 - 1. Basis-of-Design Product: Subject to compliance with requirements, provide product indicated on Drawings or comparable product by one of the following:
 - a. Crossville, Inc.
 - b. Daltile; Division of Dal-Tile International Inc.
 - c. Trinity Tile (Basis-of-Design).
 - 2. Composition: Porcelain.
 - 3. Module Size: 12" x 24".
 - 4. Thickness: 0.3125 inch.
 - 5. Face: Plain .
 - 6. Finish: Matte.
 - 7. Tile Color and Pattern: See drawings.
 - 8. Grout Color: See drawings.
 - 9. Trim Units: Coordinated with sizes and coursing of adjoining flat tile where applicable and matching characteristics of adjoining flat tile. Provide shapes as follows, selected from manufacturer's standard shapes:
 - a. Base Cove: Cove, module size 6" x 12".
- C. Tile Type CWT-1: Glazed ceramic tile.
 - 1. Basis-of-Design Product: Subject to compliance with requirements, provide product indicated on Drawings or comparable product by one of the following:
 - a. Daltile; Division of Dal-Tile International Inc.
 - b. Trinity Tile (Basis-of-Design).
 - c. Crossville, Inc.

2. Face Size: 4" x 12".
3. Thickness: 1/4 inch.
4. Finish: Glossy.
5. Tile Color and Pattern: See drawings.
6. Grout Color: See drawings.
7. Tile Color and Pattern: See Drawings.
8. Grout Color: See Drawings.

2.3 TILE BACKING PANELS

- A. Cementitious Backer Units: ANSI A118.9 or ASTM C 1325, in maximum lengths available to minimize end-to-end butt joints.
 1. Products: Subject to compliance with requirements, provide one of the following:
 - a. Custom Building Products; Wonderboard.
 - b. FinPan, Inc.; Util-A-Crete Concrete Backer Board.
 - c. USG Corporation; DUROCK Cement Board.
 2. Thickness: 5/8 inch.

2.4 SETTING MATERIALS

- A. Latex-Portland Cement Mortar (Thin Set): ANSI A118.4.
 1. For wall applications, provide mortar that complies with requirements for nonsagging mortar in addition to the other requirements in ANSI A118.4.

2.5 GROUT MATERIALS

- A. Water-Cleanable Epoxy Grout: ANSI A118.3, with a VOC content of 65 g/L or less when calculated according to 40 CFR 59, Subpart D.
 1. Basis-of-Design Product: Subject to compliance with requirements, provide product indicated on Drawings or comparable product by one of the following:
 - a. Bonsal American; an Oldcastle company.
 - b. Custom Building Products.
 - c. Laticrete International, Inc.
 - d. MAPEI Corporation.

2.6 MISCELLANEOUS MATERIALS

- A. Trowelable Underlayments and Patching Compounds: Latex-modified, portland cement-based formulation provided or approved by manufacturer of tile-setting materials for installations indicated.
- B. Metal Edge Strips: Angle or L-shape, height to match tile and setting-bed thickness, designed specifically for flooring applications; white zinc alloy exposed-edge material.
- C. Temporary Protective Coating: Product indicated below that is formulated to protect exposed surfaces of tile against adherence of mortar and grout; compatible with tile, mortar, and grout products; and easily removable after grouting is completed without damaging grout or tile.

1. Grout release in form of manufacturer's standard proprietary liquid coating that is specially formulated and recommended for use as temporary protective coating for tile.
- D. Tile Cleaner: A neutral cleaner capable of removing soil and residue without harming tile and grout surfaces, specifically approved for materials and installations indicated by tile and grout manufacturers.

2.7 MIXING MORTARS AND GROUT

- A. Mix mortars and grouts to comply with referenced standards and mortar and grout manufacturers' written instructions.
- B. Add materials, water, and additives in accurate proportions.
- C. Obtain and use type of mixing equipment, mixer speeds, mixing containers, mixing time, and other procedures to produce mortars and grouts of uniform quality with optimum performance characteristics for installations indicated.

PART 3 - EXECUTION

3.1 EXAMINATION

- A. Examine substrates, areas, and conditions where tile will be installed, with Installer present, for compliance with requirements for installation tolerances and other conditions affecting performance of installed tile.
 1. Verify that substrates for setting tile are firm, dry, clean, free of coatings that are incompatible with tile-setting materials including curing compounds and other substances that contain soap, wax, oil, or silicone; and comply with flatness tolerances required by ANSI A108.01 for installations indicated.
 2. Verify that concrete substrates for tile floors installed with thin-set mortar comply with surface finish requirements in ANSI A108.01 for installations indicated.
 - a. Verify that surfaces that received a steel trowel finish have been mechanically scarified.
 - b. Verify that protrusions, bumps, and ridges have been removed by sanding or grinding.
 3. Verify that installation of grounds, anchors, recessed frames, electrical and mechanical units of work, and similar items located in or behind tile has been completed.
 4. Verify that joints and cracks in tile substrates are coordinated with tile joint locations; if not coordinated, adjust joint locations in consultation with Architect.
- B. Proceed with installation only after unsatisfactory conditions have been corrected.

3.2 PREPARATION

- A. Fill cracks, holes, and depressions in concrete substrates for tile floors installed with adhesives or thin-set mortar with trowelable leveling and patching compound specifically recommended by tile-setting material manufacturer.

- B. Blending: For tile exhibiting color variations, verify that tile has been factory blended and packaged so tile units taken from one package show same range of colors as those taken from other packages and match approved Samples. If not factory blended, either return to manufacturer or blend tiles at Project site before installing.
- C. Field-Applied Temporary Protective Coating: If indicated under tile type or needed to prevent grout from staining or adhering to exposed tile surfaces, precoat them with continuous film of temporary protective coating, taking care not to coat unexposed tile surfaces.

3.3 TILE INSTALLATION

- A. Comply with TCA's "Handbook for Ceramic Tile Installation" for TCA installation methods specified in tile installation schedules. Comply with parts of the ANSI A108 Series "Specifications for Installation of Ceramic Tile" that are referenced in TCA installation methods, specified in tile installation schedules, and apply to types of setting and grouting materials used.
 - 1. For the following installations, follow procedures in the ANSI A108 Series of tile installation standards for providing 95 percent mortar coverage:
 - a. Tile floors composed of tiles 12 by 24 inches or larger.
 - b. Tile floors composed of rib-backed tiles.
- B. Extend tile work into recesses and under or behind equipment and fixtures to form complete covering without interruptions unless otherwise indicated. Terminate work neatly at obstructions, edges, and corners without disrupting pattern or joint alignments.
- C. Accurately form intersections and returns. Perform cutting and drilling of tile without marring visible surfaces. Carefully grind cut edges of tile abutting trim, finish, or built-in items for straight aligned joints. Fit tile closely to electrical outlets, piping, fixtures, and other penetrations so plates, collars, or covers overlap tile.
- D. Provide manufacturer's standard trim shapes where necessary to eliminate exposed tile edges.
- E. Jointing Pattern: Lay tile in grid pattern unless otherwise indicated. Lay out tile work and center tile fields in both directions in each space or on each wall area. Lay out tile work to minimize the use of pieces that are less than half of a tile. Provide uniform joint widths unless otherwise indicated.
 - 1. Where adjoining tiles on floor, base, walls, or trim are specified or indicated to be same size, align joints.
 - 2. Where tiles are specified or indicated to be whole integer multiples of adjoining tiles on floor, base, walls, or trim, align joints unless otherwise indicated.
- F. Joint Widths: Unless otherwise indicated, install tile with the following joint widths:
 - 1. Ceramic Wall Tile: 1/8 inch.
 - 2. Paver Tile: 1/8 inch.
- G. Expansion Joints: Provide expansion joints and other sealant-filled joints, including control, contraction, and isolation joints, where indicated. Form joints during installation of setting materials, mortar beds, and tile. Do not saw-cut joints after installing tiles.
 - 1. Where joints occur in concrete substrates, locate joints in tile surfaces directly above them.
- H. Metal Edge Strips: Install where exposed edge of tile flooring meets carpet, wood, or other flooring that finishes flush with top of tile.

3.4 TILE BACKING PANEL INSTALLATION

- A. Install cementitious backer units and treat joints according to ANSI A108.11 and manufacturer's written instructions for type of application indicated. Use latex-portland cement mortar for bonding material unless otherwise directed in manufacturer's written instructions.

3.5 CLEANING AND PROTECTING

- A. Cleaning: On completion of placement and grouting, clean all ceramic tile surfaces so they are free of foreign matter.
 - 1. Remove epoxy grout residue from tile as soon as possible.
 - 2. Clean grout smears and haze from tile according to tile and grout manufacturer's written instructions but no sooner than 10 days after installation. Use only cleaners recommended by tile and grout manufacturers and only after determining that cleaners are safe to use by testing on samples of tile and other surfaces to be cleaned. Protect metal surfaces and plumbing fixtures from effects of cleaning. Flush surfaces with clean water before and after cleaning.
 - 3. Remove temporary protective coating by method recommended by coating manufacturer and that is acceptable to tile and grout manufacturer. Trap and remove coating to prevent drain clogging.
- B. Protect installed tile work with kraft paper or other heavy covering during construction period to prevent staining, damage, and wear. If recommended by tile manufacturer, apply coat of neutral protective cleaner to completed tile walls and floors.
- C. Prohibit foot and wheel traffic from tiled floors for at least seven days after grouting is completed.
- D. Before final inspection, remove protective coverings and rinse neutral protective cleaner from tile surfaces.

3.6 INTERIOR TILE INSTALLATION SCHEDULE

- A. Interior Floor Installations, Concrete Subfloor:
 - 1. Tile Installation F115: Thin-set mortar; epoxy grout; TCA F115.
 - a. Tile Type: PP-1.
 - b. Thin-Set Mortar: Latex- portland cement mortar.
 - c. Grout: Water-cleanable epoxy grout.
- B. Interior Wall Installations, Metal Studs or Furring:
 - 1. Tile Installation W244: Thin-set mortar on cementitious backer units; TCA W244.
 - a. Tile Type: CWT-1.
 - b. Thin-Set Mortar: Latex- portland cement mortar.
 - c. Grout: Water-cleanable epoxy grout.

END OF SECTION 093000

SECTION 095113 - ACOUSTICAL PANEL CEILINGS

PART 1 - GENERAL

1.1 RELATED DOCUMENTS

- A. Drawings and general provisions of the Contract, including General and Supplementary Conditions and Division 01 Specification Sections, apply to this Section.

1.2 SUMMARY

- A. Section includes acoustical panels and exposed suspension systems for ceilings.
- B. Products furnished, but not installed under this Section, include anchors, clips, and other ceiling attachment devices to be cast in concrete.

1.3 PREINSTALLATION MEETINGS

- A. Preinstallation Conference: Conduct conference at Project site.

1.4 ACTION SUBMITTALS

- A. Product Data: For each type of product.
- B. Samples for Verification: For each component indicated and for each exposed finish required, prepared on Samples of size indicated below.
 - 1. Acoustical Panel: Set of 6-inch- square Samples of each type, color, pattern, and texture.
 - 2. Exposed Suspension-System Members, Moldings, and Trim: Set of 6-inch- long Samples of each type, finish, and color.

1.5 INFORMATIONAL SUBMITTALS

- A. Coordination Drawings for ACP-2: Reflected ceiling plans, drawn to scale, on which the following items are shown and coordinated with each other, using input from installers of the items involved:
 - 1. Suspended ceiling components.
 - 2. Items penetrating finished ceiling including the following:
 - a. Lighting fixtures.
 - b. Air outlets and inlets.
 - c. Sprinklers.
 - 3. Perimeter moldings.

- B. Product Test Reports: For each acoustical panel ceiling, for tests performed by manufacturer and witnessed by a qualified testing agency.
- C. Evaluation Reports: For each acoustical panel ceiling suspension system and anchor and fastener type, from ICC-ES.

1.6 CLOSEOUT SUBMITTALS

- A. Maintenance Data: For finishes to include in maintenance manuals.

1.7 MAINTENANCE MATERIAL SUBMITTALS

- A. Furnish extra materials that match products installed and that are packaged with protective covering for storage and identified with labels describing contents.

- 1. Acoustical Ceiling Panels: Full-size panels equal to 2 percent of quantity installed.
- 2. Suspension-System Components: Quantity of each exposed component equal to 2 percent of quantity installed.

1.8 DELIVERY, STORAGE, AND HANDLING

- A. Deliver acoustical panels, suspension-system components, and accessories to Project site in original, unopened packages and store them in a fully enclosed, conditioned space where they will be protected against damage from moisture, humidity, temperature extremes, direct sunlight, surface contamination, and other causes.
- B. Before installing acoustical panels, permit them to reach room temperature and a stabilized moisture content.
- C. Handle acoustical panels carefully to avoid chipping edges or damaging units in any way.

1.9 FIELD CONDITIONS

- A. Environmental Limitations: Do not install acoustical panel ceilings until spaces are enclosed and weatherproof, wet work in spaces is complete and dry, work above ceilings is complete, and ambient temperature and humidity conditions are maintained at the levels indicated for Project when occupied for its intended use.
 - 1. Pressurized Plenums: Operate ventilation system for not less than 48 hours before beginning acoustical panel ceiling installation.

PART 2 - PRODUCTS

2.1 PERFORMANCE REQUIREMENTS

- A. Seismic Performance: Acoustical ceiling shall withstand the effects of earthquake motions determined according to ASCE/SEI 7 Seismic Design Category "C".
 - 1. Refer to drawings for project specific seismic requirements.

- B. Surface-Burning Characteristics: Comply with ASTM E 84; testing by a qualified testing agency. Identify products with appropriate markings of applicable testing agency.
 - 1. Flame-Spread Index: Comply with ASTM E 1264 for Class A materials.
 - 2. Smoke-Developed Index: 50 or less.
- C. Fire-Resistance Ratings: Comply with ASTM E 119; testing by a qualified testing agency. Identify products with appropriate markings of applicable testing agency.

2.2 ACOUSTICAL PANELS, GENERAL

- A. Source Limitations:
 - 1. Acoustical Ceiling Panel: Obtain each type from single source from single manufacturer.
 - 2. Suspension System: Obtain each type from single source from single manufacturer.
- B. Source Limitations: Obtain each type of acoustical ceiling panel and supporting suspension system from single source from single manufacturer.
- C. Glass-Fiber-Based Panels: Made with binder containing no urea formaldehyde.
- D. Acoustical Panel Standard: Provide manufacturer's standard panels of configuration indicated that comply with ASTM E 1264 classifications as designated by types, patterns, acoustical ratings, and light reflectances unless otherwise indicated.
 - 1. Mounting Method for Measuring NRC: Type E-400; plenum mounting in which face of test specimen is 15-3/4 inches away from test surface according to ASTM E 795.
- E. Acoustical Panel Colors and Patterns: Match appearance characteristics indicated for each product type.
 - 1. Where appearance characteristics of acoustical panels are indicated by referencing pattern designations in ASTM E 1264 and not manufacturers' proprietary product designations, provide products selected by Architect from each manufacturer's full range that comply with requirements indicated for type, pattern, color, light reflectance, acoustical performance, edge detail, and size.

2.3 ACOUSTICAL PANELS: ACP-1

- A. Manufacturers: Subject to compliance with requirements, :
- B. Basis-of-Design Product: Subject to compliance with requirements, provide Armstrong World Industries, Inc.; "OPTIMA Tegular Fine Texture" or comparable product by one of the following:
 - 1. Armstrong World Industries, Inc. (Basis-of-Design)
 - 2. CertainTeed Corp.
 - 3. USG Interiors, Inc.; Subsidiary of USG Corporation.
- C. Classification: Provide panels complying with ASTM E 1264 for type, form, and pattern as follows:
 - 1. Type and Form: Type XII, glass-fiber base with membrane-faced overlay; .
 - 2. Pattern: E (lightly textured).

- D. Color: White.
- E. LR: Not less than 0.90.
- F. NRC: Not less than 0.90.
- G. CAC: Not less than 26 CAC.
- H. AC: Not less than 200.
- I. Edge/Joint Detail: 9/16 inch square tegular.
- J. Thickness: 1 inch.
- K. Modular Size: 24 by 24 inches, reference Drawings.

2.4 ACOUSTICAL PANELS: ACP-2

- A. Basis-of-Design Product: Subject to compliance with requirements, provide Armstrong World Industries, Inc.; "Metalworks Tegular Smooth Texture" product indicated on Drawings or comparable product by one of the following:
 - 1. CertainTeed Corp.
 - 2. Armstrong World Industries, Inc. (Basis-of-Design)
 - 3. USG Interiors, Inc.; Subsidiary of USG Corporation.
- B. Classification: Provide panels complying with ASTM E 1264 for type, form, and pattern as follows:
 - 1. Type and Form: Type XX, other types; described as high-density, ceramic- and mineral-base panels with scrubbable finish, resistant to heat, moisture, and corrosive fumes.
 - 2. Pattern: C, perforated, small holes. (M2 microperforated)
- C. Color: Silver Grey SG.
- D. LR: Not less than 0.61.
- E. NRC: Not less than 0.90.
- F. 9/16 inch Square Tegular Edge.
- G. Thickness: 1 inch (19 mm).
- H. Modular Size: 24 by 24 inches (610 by 610 mm), reference Drawings.

2.5 METAL SUSPENSION SYSTEMS, GENERAL

- A. Metal Suspension-System Standard: Provide manufacturer's standard direct-hung metal suspension systems of types, structural classifications, and finishes indicated that comply with applicable requirements in ASTM C 635/C 635M.
- B. Attachment Devices: Size for five times the design load indicated in ASTM C 635/C 635M, Table 1, "Direct Hung," unless otherwise indicated. Comply with seismic design requirements.

- C. Wire Hangers, Braces, and Ties: Provide wires complying with the following requirements:
1. Zinc-Coated, Carbon-Steel Wire: ASTM A 641/A 641M, Class 1 zinc coating, soft temper.
 2. Size: Select wire diameter so its stress at three times hanger design load (ASTM C 635/C 635M, Table 1, "Direct Hung") will be less than yield stress of wire, but provide not less than 0.106-inch- diameter wire.
- D. Hanger Rods: Mild steel, zinc coated or protected with rust-inhibitive paint.
- E. Seismic Stabilizer Bars: Manufacturer's standard perimeter stabilizers designed to accommodate seismic forces and improve stability of system and panel alignment in nonseismic installations.

2.6 METAL SUSPENSION SYSTEM

- A. Manufacturers: Subject to compliance with requirements, provide products by the following:
- B. Basis-of-Design Product for ACP-1: Subject to compliance with requirements, provide Armstrong World Industries, Inc.; "Suprafine XL" or comparable product by one of the following:
1. CertainTeed Corp.
 2. Armstrong World Industries, Inc. (Basis-of-Design)
 3. USG Interiors, Inc.; Subsidiary of USG Corporation.
- C. Narrow-Face Single-Web, Extruded-Aluminum Suspension System: Main and cross runners formed from extruded aluminum to produce structural members with 9/16 inch wide faces.
1. Structural Classification: Intermediate duty system
 2. Face Design: Screw-slot profile
 3. Face Finish: Painted white
 4. Reveal Finish: Match
- D. Basis-of-Design Product for ACP-2: Subject to compliance with requirements, provide Armstrong World Industries, Inc.; "Suprafine XL" or comparable product by one of the following:
1. CertainTeed Corp.
 2. Armstrong World Industries, Inc. (Basis-of-Design)
 3. USG Interiors, Inc.; Subsidiary of USG Corporation.
- E. Narrow-Face Single-Web, Extruded-Aluminum Suspension System: Main and cross runners formed from extruded aluminum to produce structural members with 9/16 inch wide faces.
1. Structural Classification: Intermediate duty system
 2. Face Design: Screw-slot profile
 3. Face Finish: Silver Grey SG
 4. Reveal Finish: Match

2.7 METAL EDGE MOLDINGS AND TRIM

- A. Manufacturers: Subject to compliance with requirements, provide products by the following:
- B. Basis-of-Design Product for ACP-2: Subject to compliance with requirements, provide Armstrong World Industries, Inc.; "Axiom Classic Trim – 8 inch" or comparable product by one of the following:
 - 1. CertainTeed Corp.
 - 2. Armstrong World Industries, Inc. (Basis-of-Design)
 - 3. USG Interiors, Inc.; Subsidiary of USG Corporation.
- C. Narrow-Face Single-Web, Extruded-Aluminum Suspension System: Main and cross runners formed from extruded aluminum to produce structural members with 9/16 inch wide faces.
 - 1. Structural Classification: Intermediate duty system
 - 2. Face Design: Screw-slot profile
 - 3. Face Finish: Silver Grey SG
 - 4. Reveal Finish: Match
- D. Roll-Formed, Sheet-Metal Edge Moldings and Trim: Type and profile indicated or, if not indicated, manufacturer's standard moldings for edges and penetrations that comply with seismic design requirements; formed from sheet metal of same material, finish, and color as that used for exposed flanges of suspension-system runners.
 - 1. Provide manufacturer's standard edge moldings that fit acoustical panel edge details and suspension systems indicated and that match width and configuration of exposed runners unless otherwise indicated.
 - 2. For lay-in panels with reveal edge details, provide stepped edge molding that forms reveal of same depth and width as that formed between edge of panel and flange at exposed suspension member.
 - 3. For circular penetrations of ceiling, provide edge moldings fabricated to diameter required to fit penetration exactly.

PART 3 - EXECUTION

3.1 EXAMINATION

- A. Examine substrates, areas, and conditions, including structural framing to which acoustical panel ceilings attach or abut, with Installer present, for compliance with requirements specified in this and other Sections that affect ceiling installation and anchorage and with requirements for installation tolerances and other conditions affecting performance of acoustical panel ceilings.
- B. Examine acoustical panels before installation. Reject acoustical panels that are wet, moisture damaged, or mold damaged.
- C. Proceed with installation only after unsatisfactory conditions have been corrected.

3.2 PREPARATION

- A. Measure each ceiling area and establish layout of acoustical panels to balance border widths at opposite edges of each ceiling. Avoid using less-than-half-width panels at borders, and comply with layout shown on reflected ceiling plans.

3.3 INSTALLATION

- A. General: Install acoustical panel ceilings to comply with ASTM C 636/C 636M and seismic design requirements indicated, according to manufacturer's written instructions and CISCA's "Ceiling Systems Handbook."
1. CISCA recommendations for Design Category C:
 - a. Minimum 7/8" wall molding.
 - b. Grid must not be attached to wall molding.
 - c. Minimum 3/8" clearance on all sides.
 - d. Ends of main beams and cross tees must be tied together to prevent their spreading.
 - e. Safety wires required on light fixtures.
- B. Suspend ceiling hangers from building's structural members and as follows:
1. Install hangers plumb and free from contact with insulation or other objects within ceiling plenum that are not part of supporting structure or of ceiling suspension system.
 2. Where width of ducts and other construction within ceiling plenum produces hanger spacings that interfere with location of hangers at spacings required to support standard suspension-system members, install supplemental suspension members and hangers in form of trapezes or equivalent devices.
 3. Secure wire hangers to ceiling-suspension members and to supports above with a minimum of three tight turns. Connect hangers directly either to structures or to inserts, eye screws, or other devices that are secure and appropriate for substrate and that will not deteriorate or otherwise fail due to age, corrosion, or elevated temperatures.
 4. Do not support ceilings directly from permanent metal forms or floor deck. Fasten hangers to cast-in-place hanger inserts, postinstalled mechanical or adhesive anchors, or power-actuated fasteners that extend through forms into concrete.
 5. When steel framing does not permit installation of hanger wires at spacing required, install carrying channels or other supplemental support for attachment of hanger wires.
 6. Do not attach hangers to steel deck tabs.
 7. Do not attach hangers to steel roof deck. Attach hangers to structural members.
 8. Space hangers not more than 48 inches o.c. along each member supported directly from hangers unless otherwise indicated; provide hangers not more than 8 inches from ends of each member.
 9. Size supplemental suspension members and hangers to support ceiling loads within performance limits established by referenced standards and publications.
- C. Secure bracing wires to ceiling suspension members and to supports with a minimum of three tight turns. Suspend bracing from building's structural members as required for hangers, without attaching to permanent metal forms, steel deck, or steel deck tabs. Fasten bracing wires into concrete with cast-in-place or postinstalled anchors.
- D. Install edge moldings and trim of type indicated at perimeter of acoustical ceiling area and where necessary to conceal edges of acoustical panels.
1. Screw attach moldings to substrate at intervals not more than 16 inches o.c. and not more than 3 inches from ends, leveling with ceiling suspension system to a tolerance of 1/8 inch in 12 feet. Miter corners accurately and connect securely.
 2. Do not use exposed fasteners, including pop rivets, on moldings and trim.

- E. Install suspension-system runners so they are square and securely interlocked with one another. Remove and replace dented, bent, or kinked members.
- F. Install acoustical panels with undamaged edges and fit accurately into suspension-system runners and edge moldings. Scribe and cut panels at borders and penetrations to provide a neat, precise fit.
 - 1. Arrange directionally patterned acoustical panels as follows:
 - a. Install panels in a basket-weave pattern.
 - 2. For square-edged panels, install panels with edges fully hidden from view by flanges of suspension-system runners and moldings.
 - 3. For reveal-edged panels on suspension-system runners, install panels with bottom of reveal in firm contact with top surface of runner flanges.
 - 4. Paint cut edges of panel remaining exposed after installation; match color of exposed panel surfaces using coating recommended in writing for this purpose by acoustical panel manufacturer.
 - 5. Install impact clips in areas indicated, in areas required by authorities having jurisdiction, and for fire-resistance ratings; space as recommended by panel manufacturer's written instructions unless otherwise indicated.

3.4 FIELD QUALITY CONTROL

- A. Special Inspections: Owner will engage a qualified special inspector to perform the following special inspections:
 - 1. Compliance of seismic design.
- B. Perform the following tests and inspections of completed installations of acoustical panel ceiling hangers and anchors and fasteners in successive stages. Do not proceed with installations of acoustical panel ceiling hangers for the next area until test results for previously completed installations show compliance with requirements.
 - 1. Extent of Each Test Area: When installation of ceiling suspension systems on each floor has reached 20 percent completion but no panels have been installed.
 - a. Within each test area, testing agency will select one of every 10 power-actuated fasteners and postinstalled anchors used to attach hangers to concrete and will test them for 200 lbf of tension; it will also select one of every two postinstalled anchors used to attach bracing wires to concrete and will test them for 440 lbf of tension.
 - b. When testing discovers fasteners and anchors that do not comply with requirements, testing agency will test those anchors not previously tested until 20 pass consecutively and then will resume initial testing frequency.
- C. Acoustical panel ceiling hangers and anchors and fasteners will be considered defective if they do not pass tests and inspections.
- D. Prepare test and inspection reports.

3.5 CLEANING

- A. Clean exposed surfaces of acoustical panel ceilings, including trim, edge moldings, and suspension-system members. Comply with manufacturer's written instructions for cleaning and touchup of minor finish damage. Remove and replace ceiling components that cannot be successfully cleaned and repaired to permanently eliminate evidence of damage.

END OF SECTION 095113

SECTION 096513 - RESILIENT BASE AND ACCESSORIES

PART 1 - GENERAL

1.1 RELATED DOCUMENTS

- A. Drawings and general provisions of the Contract, including General and Supplementary Conditions and Division 01 Specification Sections, apply to this Section.

1.2 SUMMARY

- A. Section Includes:
 - 1. Resilient base.
 - 2. Resilient molding accessories.

1.3 ACTION SUBMITTALS

- A. Product Data: For each type of product indicated.

1.4 MAINTENANCE MATERIAL SUBMITTALS

- A. Furnish extra materials that match products installed and that are packaged with protective covering for storage and identified with labels describing contents.
 - 1. Furnish not less than 20 linear feetInsert length for every 500 linear feet or fraction thereof, of each type, color, pattern, and size of resilient product installed.

1.5 QUALITY ASSURANCE

- A. Fire-Test-Response Characteristics: As determined by testing identical products according to ASTM E 648 or NFPA 253 by a qualified testing agency.
 - 1. Critical Radiant Flux Classification: Class I, not less than 0.45 W/sq. cm.

1.6 DELIVERY, STORAGE, AND HANDLING

- A. Store resilient products and installation materials in dry spaces protected from the weather, with ambient temperatures maintained within range recommended by manufacturer, but not less than 50 deg F or more than 90 deg F.

1.7 PROJECT CONDITIONS

- A. Maintain ambient temperatures within range recommended by manufacturer, but not less than 70 deg F or more than 95 deg F, in spaces to receive resilient products during the following time periods:
 - 1. 48 hours before installation.

2. During installation.
 3. 48 hours after installation.
- B. Until Substantial Completion, maintain ambient temperatures within range recommended by manufacturer, but not less than 55 deg F or more than 95 deg F.
- C. Install resilient products after other finishing operations, including painting, have been completed.

PART 2 - PRODUCTS

2.1 RESILIENT BASE RES-1

- A. Resilient Base:
1. Manufacturers: Basis-of-Design Product: Subject to compliance with requirements, provide products by one of the following:
 - a. Armstrong World Industries, Inc.
 - b. Johnsonite.(Basis-of-Design)
 - c. Mannington.
- B. Resilient Base Standard: ASTM F 1861.
1. Material Requirement: Type TP (rubber, thermoplastic).
 2. Manufacturing Method: Group I (solid, homogeneous).
 3. Style: Cove (base with toe).
- C. Minimum Thickness: 0.125 inch.
- D. Height: 4 inches.
- E. Lengths: Coils in manufacturer's standard length.
- F. Outside Corners: Preformed.
- G. Inside Corners: Preformed.
- H. Colors and Patterns: . See drawings.

2.2 RESILIENT MOLDING ACCESSORY

- A. Resilient Molding Accessory:
1. Manufacturers: Subject to compliance with requirements, provide products by one of the following:
 - a. Johnsonite.(Basis-of-Design)
 - b. Armstrong.
 - c. Mannington
- B. Description: Transition strips.
- C. Material: Rubber.

- D. Profile and Dimensions: As indicated.
- E. Colors and Patterns: . See drawings.

2.3 INSTALLATION MATERIALS

- A. Trowelable Leveling and Patching Compounds: Latex-modified, portland cement based or blended hydraulic-cement-based formulation provided or approved by manufacturer for applications indicated.
- B. Adhesives: Water-resistant type recommended by manufacturer to suit resilient products and substrate conditions indicated.

PART 3 - EXECUTION

3.1 EXAMINATION

- A. Examine substrates, with Installer present, for compliance with requirements for maximum moisture content and other conditions affecting performance of the Work.
- B. Verify that finishes of substrates comply with tolerances and other requirements specified in other Sections and that substrates are free of cracks, ridges, depressions, scale, and foreign deposits that might interfere with adhesion of resilient products.
- C. Proceed with installation only after unsatisfactory conditions have been corrected.

3.2 PREPARATION

- A. Prepare substrates according to manufacturer's written instructions to ensure adhesion of resilient products.
- B. Concrete Substrates for Resilient Stair Treads and Accessories: Prepare according to ASTM F 710.
 - 1. Verify that substrates are dry and free of curing compounds, sealers, and hardeners.
 - 2. Remove substrate coatings and other substances that are incompatible with adhesives and that contain soap, wax, oil, or silicone, using mechanical methods recommended by manufacturer. Do not use solvents.
 - 3. Alkalinity and Adhesion Testing: Perform tests recommended by manufacturer.
 - 4. Moisture Testing: Perform tests recommended by manufacturer. Proceed with installation only after substrates pass testing.
- C. Fill cracks, holes, and depressions in substrates with trowelable leveling and patching compound and remove bumps and ridges to produce a uniform and smooth substrate.
- D. Do not install resilient products until they are same temperature as the space where they are to be installed.
 - 1. Move resilient products and installation materials into spaces where they will be installed at least 48 hours in advance of installation.
- E. Sweep and vacuum clean substrates to be covered by resilient products immediately before installation.

3.3 RESILIENT BASE INSTALLATION

- A. Comply with manufacturer's written instructions for installing resilient base.
- B. Apply resilient base to walls, columns, pilasters, casework and cabinets in toe spaces, and other permanent fixtures in rooms and areas where base is required.
- C. Install resilient base in lengths as long as practicable without gaps at seams and with tops of adjacent pieces aligned.
- D. Tightly adhere resilient base to substrate throughout length of each piece, with base in continuous contact with horizontal and vertical substrates.
- E. Do not stretch resilient base during installation.
- F. Preformed Corners: Install preformed corners before installing straight pieces.

3.4 RESILIENT ACCESSORY INSTALLATION

- A. Comply with manufacturer's written instructions for installing resilient accessories.
- B. Resilient Molding Accessories: Butt to adjacent materials and tightly adhere to substrates throughout length of each piece. Install reducer strips at edges of carpet and resilient floor covering that would otherwise be exposed. See drawings.

3.5 CLEANING AND PROTECTION

- A. Comply with manufacturer's written instructions for cleaning and protection of resilient products.
- B. Perform the following operations immediately after completing resilient product installation:
 - 1. Remove adhesive and other blemishes from exposed surfaces.
 - 2. Sweep and vacuum surfaces thoroughly.
 - 3. Damp-mop surfaces to remove marks and soil.
- C. Protect resilient products from mars, marks, indentations, and other damage from construction operations and placement of equipment and fixtures during remainder of construction period.
- D. Cover resilient products until Substantial Completion.

END OF SECTION 096513

SECTION 096519 - RESILIENT TILE FLOORING

PART 1 - GENERAL

1.1 RELATED DOCUMENTS

- A. Drawings and general provisions of the Contract, including General and Supplementary Conditions and Division 01 Specification Sections, apply to this Section.

1.2 SUMMARY

- A. Section Includes:

- 1. Plank vinyl floor tile.

1.3 ACTION SUBMITTALS

- A. Product Data: For each type of product indicated.
- B. Shop Drawings: For each type of floor tile. Include floor tile layouts, edges, columns, doorways, enclosing partitions, built-in furniture, cabinets, and cutouts.
 - 1. Show details of special patterns.
- C. Samples for Verification: Full-size units of each color and pattern of floor tile required.
- D. Product Schedule: For floor tile. Use same designations indicated on Drawings.

1.4 CLOSEOUT SUBMITTALS

- A. Maintenance Data: For each type of floor tile to include in maintenance manuals.

1.5 MATERIALS MAINTENANCE SUBMITTALS

- A. Furnish extra materials that match products installed and that are packaged with protective covering for storage and identified with labels describing contents.
 - 1. Floor Tile: Furnish 1 box for every 50 boxes or fraction thereof, of each type, color, and pattern of floor tile installed.

1.6 QUALITY ASSURANCE

- A. Installer Qualifications: A qualified installer who employs workers for this Project who are competent in techniques required by manufacturer for floor tile installation indicated.
 - 1. Engage an installer who employs workers for this Project who are trained or certified by manufacturer for installation techniques required.

1.7 DELIVERY, STORAGE, AND HANDLING

- A. Store floor tile and installation materials in dry spaces protected from the weather, with ambient temperatures maintained within range recommended by manufacturer, but not less than 50 deg F or more than 90 deg F. Store floor tiles on flat surfaces.

1.8 PROJECT CONDITIONS

- A. Maintain ambient temperatures within range recommended by manufacturer, but not less than 70 deg F or more than 95 deg F, in spaces to receive floor tile during the following time periods:
 - 1. 48 hours before installation.
 - 2. During installation.
 - 3. 48 hours after installation.
- B. Until Substantial Completion, maintain ambient temperatures within range recommended by manufacturer, but not less than 55 deg F or more than 95 deg F.
- C. Close spaces to traffic during floor tile installation.
- D. Close spaces to traffic for 48 hours after floor tile installation.
- E. Install floor tile after other finishing operations, including painting, have been completed.

PART 2 - PRODUCTS

2.1 PERFORMANCE REQUIREMENTS

- A. FloorScore Compliance: Resilient tile flooring shall comply with requirements of FloorScore Standard.

2.2 VINYL PLANK FLOOR TILE VINYL-1

- A. Manufacturers: Basis-of-Design Products: Subject to compliance with requirements, provide one of the following:
 - 1. Armstrong World Industries, Inc.; .
 - 2. Mannington Mills, Inc.; .
 - 3. Tarkett, Inc.; .
 - 4. Karndean (Basis-of-Design).
- B. Tile Standard: ASTM F 1066, Class 3, surface-pattern tile.
- C. Wearing Surface: Embossed 30 mil.
- D. Thickness: 0.125 inch.
- E. Size: See drawings.
- F. Colors and Patterns: See drawings.
- G. Static Load: 1,000 PSI

- H. Warranty: 15 years

2.3 INSTALLATION MATERIALS

- A. Trowelable Leveling and Patching Compounds: Latex-modified, portland cement based or blended hydraulic-cement-based formulation provided or approved by manufacturer for applications indicated.
- B. Adhesives: Water-resistant type recommended by manufacturer to suit floor tile and substrate conditions indicated.
- C. Floor Polish: Provide protective liquid floor polish products as recommended by manufacturer.

PART 3 - EXECUTION

3.1 EXAMINATION

- A. Examine substrates, with Installer present, for compliance with requirements for maximum moisture content and other conditions affecting performance of the Work.
- B. Verify that finishes of substrates comply with tolerances and other requirements specified in other Sections and that substrates are free of cracks, ridges, depressions, scale, and foreign deposits that might interfere with adhesion of floor tile.
- C. Proceed with installation only after unsatisfactory conditions have been corrected.

3.2 PREPARATION

- A. Prepare substrates according to manufacturer's written instructions to ensure adhesion of resilient products.
- B. Concrete Substrates: Prepare according to ASTM F 710.
 - 1. Verify that substrates are dry and free of curing compounds, sealers, and hardeners.
 - 2. Remove substrate coatings and other substances that are incompatible with adhesives and that contain soap, wax, oil, or silicone, using mechanical methods recommended by manufacturer. Do not use solvents.
 - 3. Alkalinity and Adhesion Testing: Perform tests recommended by manufacturer. Proceed with installation only after substrates pass testing.
 - 4. Moisture Testing: Perform tests recommended by manufacturer and as follows. Proceed with installation only after substrates pass testing.
 - a. Perform anhydrous calcium chloride test, ASTM F 1869. Proceed with installation only after substrates have maximum moisture-vapor-emission rate of 3 lb of water/1000 sq. ft. in 24 hours.
 - b. Perform relative humidity test using in situ probes, ASTM F 2170. Proceed with installation only after substrates have a maximum 75% relative humidity level measurement.
- C. Fill cracks, holes, and depressions in substrates with trowelable leveling and patching compound and remove bumps and ridges to produce a uniform and smooth substrate.
- D. Do not install floor tiles until they are same temperature as space where they are to be installed.

1. Move resilient products and installation materials into spaces where they will be installed at least 48 hours in advance of installation.

- E. Sweep and vacuum clean substrates to be covered by resilient products immediately before installation.

3.3 FLOOR TILE INSTALLATION

- A. Comply with manufacturer's written instructions for installing floor tile.

- B. Lay out floor tiles from center marks established with principal walls, discounting minor offsets, so tiles at opposite edges of room are of equal width. Adjust as necessary to avoid using cut widths that equal less than one-half tile at perimeter.

1. Lay tiles in pattern indicated on drawings.

- C. Match floor tiles for color and pattern by selecting tiles from cartons in the same sequence as manufactured and packaged, if so numbered. Discard broken, cracked, chipped, or deformed tiles.

1. Lay tiles in pattern of colors and sizes indicated.

- D. Scribe, cut, and fit floor tiles to butt neatly and tightly to vertical surfaces and permanent fixtures including built-in furniture, cabinets, pipes, outlets, and door frames.

- E. Extend floor tiles into toe spaces, door reveals, closets, and similar openings. Extend floor tiles to center of door openings.

- F. Maintain reference markers, holes, and openings that are in place or marked for future cutting by repeating on floor tiles as marked on substrates. Use chalk or other nonpermanent, nonstaining marking device.

- G. Install floor tiles on covers for telephone and electrical ducts, building expansion-joint covers, and similar items in finished floor areas. Maintain overall continuity of color and pattern between pieces of tile installed on covers and adjoining tiles. Tightly adhere tile edges to substrates that abut covers and to cover perimeters.

- H. Adhere floor tiles to flooring substrates using a full spread of adhesive applied to substrate to produce a completed installation without open cracks, voids, raising and puckering at joints, telegraphing of adhesive spreader marks, and other surface imperfections.

3.4 CLEANING AND PROTECTION

- A. Comply with manufacturer's written instructions for cleaning and protection of floor tile.

- B. Perform the following operations immediately after completing floor tile installation:

1. Remove adhesive and other blemishes from exposed surfaces.
2. Sweep and vacuum surfaces thoroughly.
3. Damp-mop surfaces to remove marks and soil.

- C. Protect floor tile products from marks, marks, indentations, and other damage from construction operations and placement of equipment and fixtures during remainder of construction period.

- D. Cover floor tile until Substantial Completion.

END OF SECTION 096519

SECTION 096813 - TILE CARPETING

PART 1 - GENERAL

1.1 RELATED DOCUMENTS

- A. Drawings and general provisions of the Contract, including General and Supplementary Conditions and Division 01 Specification Sections, apply to this Section.

1.2 SUMMARY

- A. Section includes modular, tufted carpet tile.

1.3 ACTION SUBMITTALS

- A. Product Data: For each type of product.
 - 1. Include manufacturer's written data on physical characteristics, durability, and fade resistance.
 - 2. Include installation recommendations for each type of substrate.
- B. Shop Drawings: Show the following:
 - 1. Columns, doorways, enclosing walls or partitions, built-in cabinets, and locations where cutouts are required in carpet tiles.
 - 2. Carpet tile type, color, and dye lot.
 - 3. Type of subfloor.
 - 4. Pattern of installation.
 - 5. Pattern type, location, and direction.
 - 6. Type, color, and location of insets and borders.
 - 7. Type, color, and location of edge, transition, and other accessory strips.
 - 8. Transition details to other flooring materials.
- C. Samples: For each of the following products and for each color and texture required. Label each Sample with manufacturer's name, material description, color, pattern, and designation indicated on Drawings and in schedules.
 - 1. Carpet Tile: Full-size Sample.
 - 2. Exposed Edge, Transition, and Other Accessory Stripping: 12-inch- long Samples.
- D. Product Schedule: For carpet tile. Use same designations indicated on Drawings.

1.4 INFORMATIONAL SUBMITTALS

- A. Product Test Reports: For carpet tile, for tests performed by a qualified testing agency.
- B. Sample Warranty: For special warranty.

1.5 CLOSEOUT SUBMITTALS

- A. Maintenance Data: For carpet tiles to include in maintenance manuals. Include the following:
1. Methods for maintaining carpet tile, including cleaning and stain-removal products and procedures and manufacturer's recommended maintenance schedule.
 2. Precautions for cleaning materials and methods that could be detrimental to carpet tile.

1.6 MAINTENANCE MATERIAL SUBMITTALS

- A. Furnish extra materials, from the same product run, that match products installed and that are packaged with protective covering for storage and identified with labels describing contents.
1. Carpet Tile: Full-size units equal to 5 percent of amount installed for each type indicated, but not less than 10 sq. yd..

1.7 QUALITY ASSURANCE

- A. Installer Qualifications: An experienced installer who is certified by the International Certified Floorcovering Installers Association at the Commercial II certification level.
- B. Fire-Test-Response Ratings: Where indicated, provide carpet tile identical to those of assemblies tested for fire response according to NFPA 253 by a qualified testing agency.

1.8 DELIVERY, STORAGE, AND HANDLING

- A. Comply with CRI 104.

1.9 FIELD CONDITIONS

- A. Comply with CRI 104 for temperature, humidity, and ventilation limitations.
- B. Environmental Limitations: Do not deliver or install carpet tiles until spaces are enclosed and weathertight, wet work in spaces is complete and dry, and ambient temperature and humidity conditions are maintained at occupancy levels during the remainder of the construction period.
- C. Do not install carpet tiles over concrete slabs until slabs have cured and are sufficiently dry to bond with adhesive and concrete slabs have pH range recommended by carpet tile manufacturer.

1.10 WARRANTY

- A. Special Warranty for Carpet Tiles: Manufacturer agrees to repair or replace components of carpet tile installation that fail in materials or workmanship within specified warranty period.
1. Warranty does not include deterioration or failure of carpet tile due to unusual traffic, failure of substrate, vandalism, or abuse.
 2. Failures include, but are not limited to, more than 10 percent edge raveling, snags, runs, dimensional stability, loss of tuft bind strength, loss of face fiber, and delamination.
 3. Warranty Period: 10 years from date of Substantial Completion.

PART 2 - PRODUCTS

2.1 CARPET TILE CPT-1

- A. Basis-of-Design Product: Subject to compliance with requirements, provide product indicated on Drawings or comparable product by one of the following:
 - 1. Milliken & Co. (produced for Starnet) (Basis-of-Design)
 - 2. Mohawk Group
 - 3. Shaw Industries Group .
- B. Color: See drawings.
- C. Pattern: See drawings.
- D. Fiber Content: 100 percent nylon 6 .
- E. Pile Characteristic: Tufted, Textured Loop pile.
- F. Pile Thickness: 0.08 inches for finished carpet tile[according to ASTM D 6859].
- G. Stitches: 10.4 per inch.
- H. Gage: 1/12 ends per inch.
- I. Surface Pile Weight: 15 oz./sq. yd..
- J. Total Weight: 92 oz./sq. yd. for finished carpet tile.
- K. Primary Backing/Backcoating: PVC-Free Underscore ES Cushion.
- L. Size: 50cm x 50cm.
- M. Installation: See Drawings.
- N. Applied Soil-Resistance Treatment: StainSmart.
- O. Antimicrobial Treatment: AlphaSan AF Built-In Protection.
- P. Performance Characteristics: As follows:
 - 1. Critical Radiant Flux Classification: Not less than 0.45 W/sq. cm.
 - 2. Colorfastness to Light: Not less than 4 after 40 AFU (AATCC fading units) according to AATCC 16, Option E.
 - 3. Antimicrobial Activity: Not less than 2-mm halo of inhibition for gram-positive bacteria, not less than 1-mm halo of inhibition for gram-negative bacteria, and no fungal growth, according to AATCC 174.
 - 4. Electrostatic Propensity: Less than 3.5 kV according to AATCC 134.

2.2 CARPET TILE CPT-2

- A. Basis-of-Design Product: Subject to compliance with requirements, provide product indicated on Drawings or comparable product by one of the following:
 - 1. Milliken & Co. (Basis of Design)
 - 2. Mohawk Group.
 - 3. Shaw Industries Group.

- B. Color: See Drawings.
- C. Pattern: See Drawings.
- D. Fiber Content: 100 percent nylon 6.
- E. Pile Characteristic: Tufted, Textured loop pile.
- F. Pile Thickness: 0.08 inches for finished carpet tile[according to ASTM D 6859].
- G. Stitches: 10.4 per inch
- H. Guage: 1/12 ends per inch
- I. Face Weight: 15 oz./sq. yd.
- J. Primary Backing: PVC-Free Underscore ES Cushion.
- K. Size: 50 cm x 50 cm.
- L. Installation: See Drawings
- M. Applied Soil-Resistance Treatment: StainSmart
- N. Antimicrobial Treatment: AlphaSan AF Built-In Protection.
- O. Performance Characteristics: As follows:
 - 1. Critical Radiant Flux Classification: Not less than 0.45 W/sq. cm.
 - 2. Colorfastness to Light: Not less than 4 after 40 AFU (AATCC fading units) according to AATCC 16, Option E.
 - 3. Electrostatic Propensity: Less than 3.5
 - 4. Antimicrobial Activity: Not less than 2-mm halo of inhibition for gram-positive bacteria, not less than 1-mm halo of inhibition for gram-negative bacteria, and no fungal growth, according to AATCC 174.
- P. Colorfastness to Light: Not less than 4 after 40 AFU (AATCC fading units) according to AATCC 16, Option E.

2.3 CARPET TILE CPT-3 & CPT-4

- A. Basis-of-Design Product: Subject to compliance with requirements, provide product indicated on Drawings or comparable product by one of the following:
 - 1. Milliken & Co. (Basis-of-Design)
 - 2. Mohawk Group
 - 3. Shaw Industries Group.
- B. Color: See Drawings.
- C. Pattern: See Drawings.
- D. Fiber Content: 100 percent nylon 6.
- E. Pile Characteristic: Level loop pile.
- F. Pile Thickness: 0.10 inches for finished carpet tile[according to ASTM D 6859].

- G. Stitches:
- H. Guage:
- I. Face Weight: 18 oz./sq. yd.
- J. Primary Backing/Backcoating: Manufacturer's standard composite materials.
- K. Size: 50cm x 50cm.
- L. Installation: Monolithic.
- M. Applied Soil-Resistance Treatment: Manufacturer's standard material.
- N. Antimicrobial Treatment: AlphaSan AF Built-In Protection
- O. Performance Characteristics: As follows:
 - 1. Critical Radiant Flux Classification: Not less than 0.22 W/sq. cm.
 - 2. Colorfastness to Light: Not less than 4 after 40 AFU (AATCC fading units) according to AATCC 16, Option E.
 - 3. Electrostatic Propensity: Less than 3
 - 4. Antimicrobial Activity: Not less than 2-mm halo of inhibition for gram-positive bacteria, not less than 1-mm halo of inhibition for gram-negative bacteria, and no fungal growth, according to AATCC 174.
- P. Colorfastness to Light: Not less than 4 after 40 AFU (AATCC fading units) according to AATCC 16, Option E.

2.4 CARPET TILE EM-1

- A. Basis-of-Design Product: Subject to compliance with requirements, provide product indicated on Drawings or comparable product by one of the following:
 - 1. Milliken & Co.
 - 2. Mohawk Group
 - 3. Shaw Industries Group. (Basis-of-Design)
- B. Color: See Drawings.
- C. Pattern: See Drawings.
- D. Fiber Content: Pet Polyester 100% Solution Dyed
- E. Pile Characteristic: Needlebond Hobnail.
- F. Pile Thickness: 0.274 inches for finished carpet tile[according to ASTM D 6859].
- G. Stitches: 11 per inch.
- H. Guage: 1/2 ends per inch.
- I. Face Weight: 49 oz./sq. yd.
- J. Primary Backing: Ecoworx Tile.
- K. Size: 24 inch by 24 inch.

- L. Installation: See Drawings.
- M. Performance Characteristics: As follows:
 - 1. Critical Radiant Flux Classification: Not less than 0.45 W/sq. cm.
 - 2. Colorfastness to Light: Not less than 4 after 40 AFU (AATCC fading units) according to AATCC 16, Option E.
 - 3. Electrostatic Propensity: Less than 3.5
 - 4. Antimicrobial Activity: Not less than 2-mm halo of inhibition for gram-positive bacteria, not less than 1-mm halo of inhibition for gram-negative bacteria, and no fungal growth, according to AATCC 174.
- N. Colorfastness to Light: Not less than 4 after 40 AFU (AATCC fading units) according to AATCC 16, Option E.

2.5 INSTALLATION ACCESSORIES

- A. Trowelable Leveling and Patching Compounds: Latex-modified, hydraulic-cement-based formulation provided or recommended by carpet tile manufacturer.
- B. Adhesives: Water-resistant, mildew-resistant, nonstaining, pressure-sensitive type to suit products and subfloor conditions indicated, that complies with flammability requirements for installed carpet tile and is recommended by carpet tile manufacturer for releasable installation.
- C. Metal Edge/Transition Strips: Extruded aluminum with mill finish of profile and width shown, of height required to protect exposed edge of carpet, and of maximum lengths to minimize running joints.

PART 3 - EXECUTION

3.1 EXAMINATION

- A. Examine substrates, areas, and conditions, with Installer present, for compliance with requirements for maximum moisture content, alkalinity range, installation tolerances, and other conditions affecting carpet tile performance. Examine carpet tile for type, color, pattern, and potential defects.
- B. Concrete Subfloors: Verify that concrete slabs comply with ASTM F 710 and the following:
 - 1. Slab substrates are dry and free of curing compounds, sealers, hardeners, and other materials that may interfere with adhesive bond. Determine adhesion and dryness characteristics by performing bond and moisture tests recommended by carpet tile manufacturer.
 - 2. Subfloor finishes comply with requirements specified in Division 03 Section "Cast-in-Place Concrete" for slabs receiving carpet tile.
 - 3. Subfloors are free of cracks, ridges, depressions, scale, and foreign deposits.
- C. Proceed with installation only after unsatisfactory conditions have been corrected.

3.2 PREPARATION

- A. General: Comply with CRI 104, Section 6.2, "Site Conditions; Floor Preparation," and with carpet tile manufacturer's written installation instructions for preparing substrates indicated to receive carpet tile installation.
- B. Use trowelable leveling and patching compounds, according to manufacturer's written instructions, to fill cracks, holes, depressions, and protrusions in substrates. Fill or level cracks, holes and depressions 1/8 inch wide or wider and protrusions more than 1/32 inch unless more stringent requirements are required by manufacturer's written instructions.
- C. Remove coatings, including curing compounds, and other substances that are incompatible with adhesives and that contain soap, wax, oil, or silicone, without using solvents. Use mechanical methods recommended in writing by carpet tile manufacturer.
- D. Broom and vacuum clean substrates to be covered immediately before installing carpet tile.

3.3 INSTALLATION

- A. General: Comply with CRI 104, Section 14, "Carpet Modules," and with carpet tile manufacturer's written installation instructions.
- B. Maintain dye lot integrity. Do not mix dye lots in same area.
- C. Cut and fit carpet tile to butt tightly to vertical surfaces, permanent fixtures, and built-in furniture including cabinets, pipes, outlets, edgings, thresholds, and nosings. Bind or seal cut edges as recommended by carpet tile manufacturer.
- D. Extend carpet tile into toe spaces, door reveals, closets, open-bottomed obstructions, removable flanges, alcoves, and similar openings.
- E. Maintain reference markers, holes, and openings that are in place or marked for future cutting by repeating on finish flooring as marked on subfloor. Use nonpermanent, nonstaining marking device.
- F. Install pattern parallel to walls and borders.

3.4 CLEANING AND PROTECTION

- A. Perform the following operations immediately after installing carpet tile:
 - 1. Remove excess adhesive, seam sealer, and other surface blemishes using cleaner recommended by carpet tile manufacturer.
 - 2. Remove yarns that protrude from carpet tile surface.
 - 3. Vacuum carpet tile using commercial machine with face-beater element.
- B. Protect installed carpet tile to comply with CRI 104, Section 16, "Protecting Indoor Installations."
- C. Protect carpet tile against damage from construction operations and placement of equipment and fixtures during the remainder of construction period. Use protection methods indicated or recommended in writing by carpet tile manufacturer.

END OF SECTION 096813

SECTION 097200 - WALL COVERINGS

PART 1 - GENERAL

1.1 RELATED DOCUMENTS

- A. Drawings and general provisions of the Contract, including General and Supplementary Conditions and Division 01 Specification Sections, apply to this Section.

1.2 SUMMARY

- A. Section Includes:
 - 1. Vinyl wall covering.
 - 2. Projection Dry Erase Wallcovering.

1.3 ACTION SUBMITTALS

- A. Product Data: For each type of product indicated. Include data on physical characteristics, durability, fade resistance, and flame-resistance characteristics.
- B. Shop Drawings: Show location and extent of each wall-covering type. Indicate pattern placement, seams and termination points.
- C. Samples for Verification: Full width by 36-inch- long section of wall covering.
 - 1. Sample from same print run or dye lot to be used for the Work, with specified treatments applied. Mark top and face of fabric.
- D. Product Schedule: For wall coverings. Use same designations indicated on Drawings.

1.4 INFORMATIONAL SUBMITTALS

- A. Qualification Data: For qualified testing agency.
- B. Product Test Reports: Based on evaluation of comprehensive tests performed by a qualified testing agency, for wall covering.

1.5 CLOSEOUT SUBMITTALS

- A. Maintenance Data: For wall coverings to include in maintenance manuals.

1.6 MAINTENANCE MATERIAL SUBMITTALS

- A. Furnish extra materials that match products installed and that are packaged with protective covering for storage and identified with labels describing contents.
 - 1. Wall-Covering Materials: For each type, full-size units equal to 5 percent of amount installed.

1.7 QUALITY ASSURANCE

- A. Fire-Test-Response Characteristics: As determined by testing identical wall coverings applied with identical adhesives to substrates according to test method indicated below by a qualified testing agency. Identify products with appropriate markings of applicable testing agency.
 - 1. Surface-Burning Characteristics: As follows, per ASTM E 84:
- B. Installer Qualifications: Installation by skilled commercial wallcovering contractor with no less than three years of documented experience installing dry erase and vinyl wallcoverings of these types and extent.

1.8 PROJECT CONDITIONS

- A. Environmental Limitations: Do not deliver or install wall coverings until spaces are enclosed and weathertight, wet work in spaces is complete and dry, work above ceilings is complete, and temporary HVAC system is operating and maintaining ambient temperature and humidity conditions at occupancy levels during the remainder of the construction period.
- B. Lighting: Do not install wall covering until a permanent level of lighting is provided on the surfaces to receive wall covering.
- C. Ventilation: Provide continuous ventilation during installation and for not less than the time recommended by wall-covering manufacturer for full drying or curing.

PART 2 - PRODUCTS

2.1 VINYL WALL COVERING VWC-1

- A. Vinyl Wall-Covering Standards: Provide products complying with the following:
 - 1. ASTM F 793 for peelable wall coverings that qualify as Category V, Type II, Commercial Serviceability products.
 - 2. Basis-of-Design Product: Provide product indicated on Drawings:
 - a. Designtex, Bocce
 - b. Source: Janye Wilkins (843) 906-0801 .
- B. Total Weight Excluding Coatings: 15 ounces.
- C. Width: 52 inch.
- D. Repeat: 50" horizontal and 48" vertical.
- E. Colors, Textures, and Patterns: See Drawings.

2.2 PROJECTION DRY ERASE WALLCOVERING VWC-2

- A. Wall-Covering Standard: Provide[mildew-resistant] wall coverings that comply with ASTM F 793 for Category V, Type II, Commercial Serviceability products.
 - 1. Basis-of-Design Product: Provide product indicated on Drawings

- a. Walltalkers, Nu-vu-rite.
 - b. Source: Joe Stewart (803) 582-8955
- B. Width: 60 inches.
- C. Colors, Textures, and Patterns: See Drawings.
- D. Composition: Non-woven backing, pigmented vinyl capped with dry erase non-glare film, and heat embossed with a bi-directional lenticular pattern.

2.3 ACCESSORIES

- A. For VWC-2, Aluminum Tray and End Caps: Clear satin, anodized aluminum tray with aluminum end caps.
- 1. Length: 4 feet
 - 2. Quantity: One per each room indicated on finish schedule.
- B. For VWC-2, Presentation Starter Kit: Provide one Waltalkers starter kit per each room indicated on finish schedule. Kit contains eight dry erase marker, one eraser, two dry erase cleaning cloths, one empty bottle for water, and one 8 ounce bottle liquid surface cleaning solution.
- C. Adhesive: Mildew-resistant, nonstaining, strippable adhesive, for use with specific wall covering and substrate application; as recommended in writing by wall-covering manufacturer.
- D. Primer/Sealer: Mildew resistant, complying with requirements in Section 099123 "Interior Painting" Section "" and recommended in writing by wall-covering manufacturer for intended substrate.
- E. Seam Tape: As recommended in writing by wall-covering manufacturer.

PART 3 - EXECUTION

3.1 EXAMINATION

- A. Examine substrates and conditions, with Installer present, for compliance with requirements for levelness, wall plumbness, maximum moisture content, and other conditions affecting performance of the Work.
- B. Proceed with installation only after unsatisfactory conditions have been corrected.

3.2 PREPARATION

- A. Comply with manufacturer's written instructions for surface preparation.
- B. Clean substrates of substances that could impair bond of wall covering, including dirt, oil, grease, mold, mildew, and incompatible primers.
- C. Prepare substrates to achieve a smooth, dry, clean, structurally sound surface free of flaking, unsound coatings, cracks, and defects.
- 1. Gypsum Board: Prime with primer as recommended in writing by primer/sealer manufacturer and wall-covering manufacturer.

- D. Check painted surfaces for pigment bleeding. Sand gloss, semigloss, and eggshell finish with fine sandpaper.
- E. Remove hardware and hardware accessories, electrical plates and covers, light fixture trims, and similar items.
- F. Acclimatize wall-covering materials by removing them from packaging in the installation areas not less than 24 hours before installation.

3.3 INSTALLATION

- A. General: Comply with wall-covering manufacturers' written installation instructions applicable to products and applications indicated except where more stringent requirements apply.
- B. Cut wall-covering strips in roll number sequence. Change roll numbers at partition breaks and corners.
- C. Install strips in same order as cut from roll.
- D. Install reversing every other strip.
- E. Install wall covering with no gaps or overlaps, no lifted or curling edges, and no visible shrinkage.
- F. For VWC-1, Install seams vertical and plumb at least 6 inches from outside corners and 6 inches from inside corners unless a change of pattern or color exists at corner. No horizontal seams are permitted.
- G. For VWC-2, Install in horizontal pattern, using a level line. No vertical seams. See Finish Legend for installation height.
- H. Fully bond wall covering to substrate. Remove air bubbles, wrinkles, blisters, and other defects.
- I. Trim edges and seams for color uniformity, pattern match, and tight closure. Butt seams without any overlay or spacing between strips.

3.4 CLEANING

- A. Remove excess adhesive at finished seams, perimeter edges, and adjacent surfaces.
- B. Use cleaning methods recommended in writing by wall-covering manufacturer.
- C. Replace strips that cannot be cleaned.
- D. Reinstall hardware and hardware accessories, electrical plates and covers, light fixture trims, and similar items.

END OF SECTION 097200

SECTION 098400 - METAL WALL SYSTEM

PART 1 - GENERAL

1.1 RELATED DOCUMENTS

- A. Drawings and General Provisions of the Contract, including General and Supplementary Conditions and Division 1 Specifications Sections apply to this Section.

1.2 SUMMARY

- A. This section includes Metal Wall Panel Systems and components as shown on drawings.

1.3 SUBMITTALS

- A. Manufacturer's Literature and Data:
 - 1. Product Data: Submit manufacturer's technical data and brochures for each type of metal wall panel required.
- B. Shop Drawings:
 - 1. Shop drawings shall show dimensions, sizes, thickness, alloys, tempers, finishes, joining, attachments, and relationship of adjoining work.
- C. Samples:
 - 1. Samples shall include 5" x 7" piece of each type of metal and finish as specified, and extrusions if required.
- D. Certification:
 - 1. Submit certificates from manufacturer of wall panels attesting that products comply with specified requirements including finish as specified.
- E. Qualification Data:
 - 1. Firms specified in "Quality Assurance" Article must demonstrate their capabilities and experience by including lists of completed projects with project names and addresses, names and addresses of architects and owners, and other information specified.

F. 1.4 QUALITY ASSURANCE

- 1. Manufacturer: Firm with manufacturing and delivery capacity required for the project, shall have successfully completed at least ten projects within the past five years, utilizing systems, materials and techniques as herein specified.
- 2. Fabricator must own and operate its own manufacturing facilities for all metal components. "Stick Built" or "Kit of Parts Systems" consisting of components from a variety of manufacturers will not be considered or accepted.
- 3. Manufacturer/Fabricator must own and operate its own Painting and Finishing facility to assure single source responsibility and quality control.

G. 1.5 DELIVERY, STORAGE & HANDLING

1. All material shall be protected during fabrication, shipment, site storage and erection to prevent damage to the finished work from other trades. Store wall panels inside a well-ventilated area, away from uncured concrete and masonry, and protected from weather, moisture, soiling, abrasion, extreme temperatures, and humidity.

PART 2 - PRODUCTS

2.1 MANUFACTURERS

- A. Metal Wall Panels Basis-of-Design: shall be manufactured by Gordon, Inc. Interior Specialties Division, 5023 Hazel Jones Road, Bossier City, LA 71111, (800) 747-8954, FAX (800) 877-8746.
- B. The listed manufacturer shall not be construed as closing specifications to other prospective manufacturers, but rather as establishing a level of quality in a metal system. Other systems may be submitted for approval as provided for in the specification at least 10 working days prior to submission of bids. Companies desiring to submit a proposal shall submit all descriptive information of the system proposed including photographs and shop drawings of at least three projects similar in detail and scope.

2.2 MATERIALS

- A. Metal Wall Panel System shall be a complete Gordon, Inc. system. All secondary framing, anchors, clips and extrusion are to be provided as complete package of this work. No exposed fasteners for metal closures are allowed.
- B. General: Provide metals free from surface blemishes where exposed to view in finished unit. Surfaces exhibiting pitting, seam marks, roller marks, stains, discolorations, or other imperfections on finished units are not acceptable. All metal shall be of the highest grade, commercial type.
- C. Metal wall panels shall be made from aluminum sheet, 3105 alloy, 0.090 inch thick, with a powder coat finish.
- D. Mounting Accessories
 1. For surface mounting to structural wall, furnish Z Clips in extruded aluminum.

2.3 FABRICATION

- A. Height of wall panels shall be up to 12'-0" without horizontal joints. Maximum size of un-fabricated sheet is 60" in width.
- B. Wall panels shall have either a closed or reveal vertical joint, as shown on the architectural drawings. All other details including base and ceiling details shall be fabricated in accordance with the architectural drawings.

2.4 FINISHES

- A. Standard Finishes
 1. Aluminum metal wall panels shall receive a micro-etched pretreatment prior to receiving an electrostatically applied ACROGUARD® Enhanced Durability super polyester powder coat paint finish. Paint color to be selected from Gordon ACROGUARD Powder Coat Color Chart (or approved custom color selection).

PART 3 - EXECUTION

3.1 INSTALLATION

- A. Install wall panels in accordance with manufacturer's written installation instructions and shop drawings.
- B. Wall Panels shall be erected plumb, level, square, true to line, securely anchored, and in proper alignment and relationship to work of other trades. Exterior joints are to be sealed by installer with backer rods and sealant.
- C. Wall Panels shall be inspected before installation to be free from dents, scratches, and other defects.

3.2 CLEANING

- A. Removal of protective covering shall occur immediately after installation to prevent adhesive transfer.
- B. Clean all surfaces following installation.
- C. Maintenance per manufacturer's finish maintenance instructions.

3.3 PROTECTION

- A. Protection of wall panels from damage by other trades after installation to be provided by general contractor.

3.4 GENERAL RESPONSIBILITY

- A. Variation from specification: Any variation from this specification resulting in additional cost to any other contractor or subcontractor on this project shall be the sole financial responsibility of the contractor for the work of this section.

END OF SECTION

SECTION 099123 - INTERIOR PAINTING

PART 1 - GENERAL

1.1 RELATED DOCUMENTS

- A. Drawings and general provisions of the Contract, including General and Supplementary Conditions and Division 01 Specification Sections, apply to this Section.

1.2 SUMMARY

- A. Section includes surface preparation and the application of paint systems on the following interior substrates:
 - 1. Concrete.
 - 2. Concrete masonry units (CMU).
 - 3. Steel.
 - 4. Galvanized metal.
 - 5. Gypsum board.
 - 6. ASJ insulation covering.

1.3 DEFINITIONS

- A. Gloss Level 1: Not more than 5 units at 60 degrees and 10 units at 85 degrees, according to ASTM D 523.
- B. Gloss Level 2: Not more than 10 units at 60 degrees and 10 to 35 units at 85 degrees, according to ASTM D 523.
- C. Gloss Level 3: 10 to 25 units at 60 degrees and 10 to 35 units at 85 degrees, according to ASTM D 523.
- D. Gloss Level 4: 20 to 35 units at 60 degrees and not less than 35 units at 85 degrees, according to ASTM D 523.
- E. Gloss Level 5: 35 to 70 units at 60 degrees, according to ASTM D 523.
- F. Gloss Level 6: 70 to 85 units at 60 degrees, according to ASTM D 523.
- G. Gloss Level 7: More than 85 units at 60 degrees, according to ASTM D 523.

1.4 ACTION SUBMITTALS

- A. Product Data: For each type of product. Include preparation requirements and application instructions.
- B. Samples for Verification: For each type of paint system and in each color and gloss of topcoat.
 - 1. Submit Samples on rigid backing, 8 inches square.
 - 2. Step coats on Samples to show each coat required for system.
 - 3. Label each coat of each Sample.
 - 4. Label each Sample for location and application area.

- C. Product List: For each product indicated, include the following:
1. Cross-reference to paint system and locations of application areas. Use same designations indicated on Drawings and in schedules.
 2. Printout of current "MPI Approved Products List" for each product category specified in Part 2, with the proposed product highlighted.
 3. VOC content.

1.5 MAINTENANCE MATERIAL SUBMITTALS

- A. Furnish extra materials[, from the same product run,] that match products installed and that are packaged with protective covering for storage and identified with labels describing contents.
1. Paint: 5 percent, but not less than 1 gal. of each material and color applied.

1.6 QUALITY ASSURANCE

- A. Installer Qualifications: A qualified contractor shall have a minimum of five (5) years proven satisfactory experience and successful completions of projects of similar scope and shall show proof before commencement of work that he will maintain a qualified crew of painters throughout the duration of the work. When requested, Contractor shall provide a list of the last three comparable jobs including, name and location, specifying authority / project manager, start / completion dates and value of the painting work.
- B. All materials, preparation and workmanship shall conform to requirements of the latest edition of the Architectural Painting Specification Manual by the Master Painters Institute (MPI) (hereafter referred to as the MPI Painting Manual) as issued by the local MPI Accredited Quality Assurance Association having jurisdiction.
- C. The painting contractor shall receive written confirmation of the specific surface preparation procedures and primers used for all fabricated steel items from the fabricator / supplier to ascertain appropriate and manufacturer compatible finish coat materials to be used before painting any such work.
- D. Mockups: Apply mockups of each paint system indicated and each color and finish selected to verify preliminary selections made under Sample submittals and to demonstrate aesthetic effects and set quality standards for materials and execution.
1. Architect will select one surface to represent surfaces and conditions for application of each paint system specified in Part 3.
 - a. Vertical and Horizontal Surfaces: Provide samples of at least 100 sq. ft..
 2. Final approval of color selections will be based on mockups.
 - a. If preliminary color selections are not approved, apply additional mockups of additional colors selected by Architect at no added cost to Owner.
 3. Approval of mockups does not constitute approval of deviations from the Contract Documents contained in mockups unless Architect specifically approves such deviations in writing.
 4. Subject to compliance with requirements, approved mockups may become part of the completed Work if undisturbed at time of Substantial Completion.

1.7 DELIVERY, STORAGE, AND HANDLING

- A. Deliver all painting materials in sealed, original labeled containers bearing manufacturer's name, brand name, type of paint or coating and color designation, standard compliance, materials content as well as mixing and/or reducing and application requirements.
- B. Store materials not in use in tightly covered containers in well-ventilated areas with ambient temperatures continuously maintained at not less than 45 deg F.
 - 1. Maintain containers in clean condition, free of foreign materials and residue.
 - 2. Remove rags and waste from storage areas daily.

1.8 FIELD CONDITIONS

- A. Apply paints only when temperature of surfaces to be painted and ambient air temperatures are between 50 and 95 deg F.
- B. Do not apply paints when relative humidity exceeds 85 percent; at temperatures less than 5 deg F above the dew point; or to damp or wet surfaces.
- C. Perform no painting or decorating work unless a minimum lighting level of 323 Lux (30 foot candles) is provided on surfaces to be painted or decorated.
- D. Apply paint only to dry, clean, properly cured and adequately prepared surfaces in areas where dust is no longer generated by construction activities such that airborne particles will not affect the quality of finished surfaces. Concrete and masonry surfaces must be installed at least 28 days prior to painting and must be visually dry on both sides.

PART 2 - PRODUCTS

2.1 MANUFACTURERS

- A. Manufacturers: Basis-of-Design: Subject to compliance with requirements, provide products by one of the following:
 - 1. Benjamin Moore & Co.
 - 2. Sherwin-Williams Company (The) (Basis-of-Design)
 - 3. Porter Paints

2.2 PAINT, GENERAL

- A. MPI Standards: Provide products that comply with MPI standards indicated and that are listed in its "MPI Approved Products List."
- B. Material Compatibility:
 - 1. Provide materials for use within each paint system that are compatible with one another and substrates indicated, under conditions of service and application as demonstrated by manufacturer, based on testing and field experience.
 - 2. For each coat in a paint system, provide products recommended in writing by manufacturers of topcoat for use in paint system and on substrate indicated.
- C. Colors: As indicated in a color schedule. Refer to Drawings.

2.3 SOURCE QUALITY CONTROL

- A. Testing of Paint Materials: Owner reserves the right to invoke the following procedure:
1. Owner will engage the services of a qualified testing agency to sample paint materials. Contractor will be notified in advance and may be present when samples are taken. If paint materials have already been delivered to Project site, samples may be taken at Project site. Samples will be identified, sealed, and certified by testing agency.
 2. Testing agency will perform tests for compliance with product requirements.
 3. Owner may direct Contractor to stop applying coatings if test results show materials being used do not comply with product requirements. Contractor shall remove noncomplying paint materials from Project site, pay for testing, and repaint surfaces painted with rejected materials. Contractor will be required to remove rejected materials from previously painted surfaces if, on repainting with complying materials, the two paints are incompatible.

PART 3 - EXECUTION

3.1 EXAMINATION

- A. Examine substrates and conditions, with Applicator present, for compliance with requirements for maximum moisture content and other conditions affecting performance of the Work.
- B. Maximum Moisture Content of Substrates: When measured with an electronic moisture meter as follows:
1. Concrete: 12 percent.
 2. Gypsum Board: 12 percent.
- C. Gypsum Board Substrates: Verify that finishing compound is sanded smooth.
- D. Verify suitability of substrates, including surface conditions and compatibility with existing finishes and primers.
- E. Proceed with coating application only after unsatisfactory conditions have been corrected.
1. Application of coating indicates acceptance of surfaces and conditions.

3.2 PREPARATION

- A. Comply with manufacturer's written instructions and recommendations in "MPI Manual" applicable to substrates indicated.
- B. Remove hardware, covers, plates, and similar items already in place that are removable and are not to be painted. If removal is impractical or impossible because of size or weight of item, provide surface-applied protection before surface preparation and painting.
1. After completing painting operations, use workers skilled in the trades involved to reinstall items that were removed. Remove surface-applied protection if any.
- C. Clean substrates of substances that could impair bond of paints, including dust, dirt, oil, grease, and incompatible paints and encapsulants.
1. Remove incompatible primers and reprime substrate with compatible primers or apply tie coat as required to produce paint systems indicated.

- D. Concrete Substrates: Remove release agents, curing compounds, efflorescence, and chalk. Do not paint surfaces if moisture content or alkalinity of surfaces to be painted exceeds that permitted in manufacturer's written instructions.
- E. Masonry Substrates: Remove efflorescence and chalk. Do not paint surfaces if moisture content or alkalinity of surfaces or mortar joints exceed that permitted in manufacturer's written instructions.
- F. Steel Substrates: Remove rust, loose mill scale, and shop primer, if any. Clean using methods recommended in writing by paint manufacturer
- G. Galvanized-Metal Substrates: Remove grease and oil residue from galvanized sheet metal fabricated from coil stock by mechanical methods to produce clean, lightly etched surfaces that promote adhesion of subsequently applied paints.

3.3 APPLICATION

- A. Apply paints according to manufacturer's written instructions and to recommendations in "MPI Manual."
 - 1. Use applicators and techniques suited for paint and substrate indicated.
 - 2. Paint surfaces behind movable equipment and furniture same as similar exposed surfaces. Before final installation, paint surfaces behind permanently fixed equipment or furniture with prime coat only.
 - 3. Paint front and backsides of access panels, removable or hinged covers, and similar hinged items to match exposed surfaces.
 - 4. Do not paint over labels of independent testing agencies or equipment name, identification, performance rating, or nomenclature plates.
 - 5. Primers specified in painting schedules may be omitted on items that are factory primed or factory finished if acceptable to topcoat manufacturers.
- B. Tint each undercoat a lighter shade to facilitate identification of each coat if multiple coats of same material are to be applied. Tint undercoats to match color of topcoat, but provide sufficient difference in shade of undercoats to distinguish each separate coat.
- C. If undercoats or other conditions show through topcoat, apply additional coats until cured film has a uniform paint finish, color, and appearance.
- D. Apply paints to produce surface films without cloudiness, spotting, holidays, laps, brush marks, roller tracking, runs, sags, ropiness, or other surface imperfections. Cut in sharp lines and color breaks.
- E. Painting Fire Suppression, Plumbing, HVAC, Electrical, Communication, and Electronic Safety and Security Work:
 - a. .
 - 2. Paint the following work where exposed in occupied spaces Lobby/Gallery 208 and Conference 209:
 - a. Uninsulated metal piping.
 - b. Pipe hangers and supports.
 - c. Metal conduit.
 - d. Fire Suppression

3.4 FIELD QUALITY CONTROL

- A. Dry Film Thickness Testing: Owner may engage the services of a qualified testing and inspecting agency to inspect and test paint for dry film thickness.
1. Contractor shall touch up and restore painted surfaces damaged by testing.
 2. If test results show that dry film thickness of applied paint does not comply with paint manufacturer's written recommendations, Contractor shall pay for testing and apply additional coats as needed to provide dry film thickness that complies with paint manufacturer's written recommendations.

3.5 CLEANING AND PROTECTION

- A. At end of each workday, remove rubbish, empty cans, rags, and other discarded materials from Project site.
- B. After completing paint application, clean spattered surfaces. Remove spattered paints by washing, scraping, or other methods. Do not scratch or damage adjacent finished surfaces.
- C. Protect work of other trades against damage from paint application. Correct damage to work of other trades by cleaning, repairing, replacing, and refinishing, as approved by Architect, and leave in an undamaged condition.
- D. At completion of construction activities of other trades, touch up and restore damaged or defaced painted surfaces.

3.6 INTERIOR PAINTING SCHEDULE

- A. Concrete Substrates, Nontraffic Surfaces:
1. Latex System:
 - a. Prime Coat: Primer sealer, latex, interior, MPI #50.
 - b. Intermediate Coat: Latex, interior, matching topcoat.
 - c. Topcoat: Latex, interior, (Gloss Level 2), MPI #44.
- B. Concrete Substrates, Traffic Surfaces:
1. Latex Floor Enamel System:
 - a. Prime Coat: Floor paint, latex, low gloss (maximum Gloss Level 3), MPI #60.
 - b. Topcoat: Floor paint, latex, low gloss (maximum Gloss Level 3), MPI #60.
 2. Water-Based Clear Sealer System:
 - a. First Coat: Sealer, water based, for concrete floors, MPI #99.
 - b. Topcoat: Sealer, water based, for concrete floors, MPI #99.
- C. CMU Substrates:
1. Latex System:
 - a. Block Filler: Block filler, latex, interior/exterior, MPI #4.
 - b. Intermediate Coat: Latex, interior, matching topcoat.
 - c. Topcoat: Latex, interior, (Gloss Level 2), MPI #44.

D. Steel Substrates:

1. Latex over Alkyd Primer System:

- a. Prime Coat: Primer, alkyd, anti-corrosive, for metal, MPI #79.
- b. Intermediate Coat: Latex, interior, matching topcoat.
- c. Topcoat: Latex, interior, semi-gloss, (Gloss Level 5), MPI #54.

E. Galvanized-Metal Substrates:

1. Institutional Low-Odor/VOC Latex System:

- a. Prime Coat: Primer, galvanized, water based, MPI #134.
- b. Intermediate Coat: Latex, interior, institutional low odor/VOC, matching topcoat.
- c. Topcoat: Latex, interior, institutional low odor/VOC, semi-gloss (Gloss Level 5), MPI #147.

F. Gypsum Board Substrates:

1. Latex System:

- a. Prime Coat: Primer sealer, latex, interior, MPI #50.
- b. Intermediate Coat: Latex, interior, matching topcoat.
- c. Topcoat: Latex, interior, (Gloss Level 3), MPI #52.

2. High-Performance Architectural Latex System:

- a. Prime Coat: Primer sealer, latex, interior, MPI #50.
- b. Topcoat: Latex, interior, high performance architectural, (Gloss Level 3), MPI #139.

G. ASJ Insulation-Covering Substrates: Including pipe and duct coverings Insert description.

1. Latex System:

- a. Prime Coat: Primer sealer, latex, interior, MPI #50.
- b. Topcoat: Latex, interior, (Gloss Level 2), MPI #44.

END OF SECTION 099123

SECTION 099300 - STAINING AND TRANSPARENT FINISHING

PART 1 - GENERAL

1.1 RELATED DOCUMENTS

- A. Drawings and general provisions of the Contract, including General and Supplementary Conditions and Division 01 Specification Sections, apply to this Section.

1.2 SUMMARY

- A. This Section includes surface preparation and the application of wood finishes on the following substrates:
 - 1. Interior Substrates:
 - a. Dressed lumber (finish carpentry).
- B. Related Sections include the following:
 - 1. Division 09 wood flooring Sections for stains and transparent finishes applied to wood flooring.
 - 2. Division 09 Section "Interior Painting" for surface preparation and application of standard paint systems on interior substrates.

1.3 SUBMITTALS

- A. Product Data: For each type of product indicated.
- B. Samples for Verification: For each type of finish system and in each color and gloss of finish indicated.
 - 1. Submit Samples on representative samples of actual wood substrates, 8 inches square.
 - 2. Label each Sample for location and application area.
- C. Product List: For each product indicated, include the following:
 - 1. Cross-reference to finish system and locations of application areas. Use same designations indicated on Drawings and in schedules.
 - 2. Printout of MPI's current "MPI Approved Products List" for each product category specified in Part 2, with the product proposed for use highlighted.

1.4 QUALITY ASSURANCE

- A. MPI Standards:
 - 1. Products: Complying with MPI standards indicated and listed in its "MPI Approved Products List."
 - 2. Preparation and Workmanship: Comply with requirements in "MPI Architectural Painting Specification Manual" for products and finish systems indicated.

1.5 DELIVERY, STORAGE, AND HANDLING

- A. Store materials not in use in tightly covered containers in well-ventilated areas with ambient temperatures continuously maintained at not less than 45 deg F .
 - 1. Maintain containers in clean condition, free of foreign materials and residue.
 - 2. Remove rags and waste from storage areas daily.

1.6 PROJECT CONDITIONS

- A. Apply finishes only when temperature of surfaces to be finished and ambient air temperatures are between 50 and 95 deg F .
- B. Do not apply exterior finishes in snow, rain, fog, or mist; when relative humidity exceeds 85 percent; at temperatures less than 5 deg F above the dew point; or to damp or wet surfaces.

PART 2 - PRODUCTS

2.1 MANUFACTURERS

- A. Available Manufacturers: Subject to compliance with requirements, manufacturers offering products that may be incorporated into the Work include, but are not limited to, the following:
- B. Manufacturers: Subject to compliance with requirements, provide products by one of the following:
 - 1. Benjamin Moore & Co.
 - 2. Cabot Incorporated, Samuel.
 - 3. Sherwin-Williams Company (The)

2.2 MATERIALS, GENERAL

- A. Material Compatibility:
 - 1. Provide materials for use within each finish system that are compatible with one another and substrates indicated, under conditions of service and application as demonstrated by manufacturer, based on testing and field experience.
 - 2. For each coat in a finish system, provide products recommended in writing by manufacturers of topcoat for use in finish system and on substrate indicated.
- B. VOC Content of Field-Applied Interior Primers, Stains, and Transparent Finishes: Provide products that comply with the following limits for VOC content, exclusive of colorants added to a tint base, when calculated according to 40 CFR 59, Subpart D (EPA Method 24); these requirements do not apply to primers, stains, and transparent finishes that are applied in a fabrication or finishing shop:
 - 1. Flat Primers: VOC content of not more than 50 g/L.
 - 2. Nonflat Primers: VOC content of not more than 150 g/L.
 - 3. Clear Wood Finishes, Varnishes: VOC not more than 350 g/L.
 - 4. Clear Wood Finishes, Lacquers: VOC not more than 550 g/L.
 - 5. Floor Coatings: VOC not more than 100 g/L.
 - 6. Shellacs, Clear: VOC not more than 730 g/L.
 - 7. Stains: VOC not more than 250 g/L.

- C. Stain Colors: Match Architect's samples.

2.3 WOOD FILLERS

- A. Wood Filler Paste: MPI #91.
 - 1. VOC Content: E Range of E3.

2.4 PRIMERS AND SEALERS

- A. Fire Retardant Additive:
 - 1. Unishield International, LLC; Universal Fire Shield. (Basis-of-Design Product).
- B. Wood Preservative: MPI #37.
 - 1. VOC Content: E Range of E3.
- C. Lacquer Sanding Sealer: MPI #84.
 - 1. VOC Content: E Range of E3.
- D. Shellac: MPI #88.
 - 1. VOC Content: E Range of E3.

2.5 STAINS

- A. Exterior Semitransparent Stain (Solvent Based): MPI #13.
 - 1. VOC Content: E Range of E2.
- B. Interior Wood Stain (Semitransparent): MPI #90.
 - 1. VOC Content: E Range of E2.

2.6 POLYURETHANE FINISHES

- A. Interior, Oil-Modified, Clear Urethane (Satin): MPI #57, Gloss Level 4.
 - 1. VOC Content: E Range of E2.

PART 3 - EXECUTION

3.1 EXAMINATION

- A. Examine substrates and conditions, with Applicator present, for compliance with requirements for maximum moisture content and other conditions affecting performance of work.
 - 1. Maximum Moisture Content of Wood Substrates: 15 percent when measured with an electronic moisture meter.

2. Verify compatibility with and suitability of substrates, including compatibility with existing finishes.
3. Begin finish application only after unsatisfactory conditions have been corrected and surfaces are dry.
4. Beginning application of finish system constitutes Contractor's acceptance of substrate and conditions.

3.2 PREPARATION

- A. Comply with manufacturer's written instructions and recommendations in "MPI Architectural Painting Specification Manual" applicable to substrates indicated.
- B. Remove plates, machined surfaces, and similar items already in place that are not to be finished. If removal is impractical or impossible because of size or weight of item, provide surface-applied protection before surface preparation and finishing.
 1. After completing finishing operations, reinstall items that were removed; use workers skilled in the trades involved. Remove surface-applied protection if any.
- C. Clean and prepare surfaces to be finished according to manufacturer's written instructions for each particular substrate condition and as specified.
 1. Remove surface dirt, oil, or grease by washing with a detergent solution; rinse thoroughly with clean water and allow to dry. Remove grade stamps and pencil marks by sanding lightly. Remove loose wood fibers by brushing.
 2. Remove mildew by scrubbing with a commercial wash formulated for mildew removal and as recommended by stain manufacturer.
 3. Countersink steel nails, if used, and fill with putty tinted to final color to eliminate rust leach stains.
- D. Apply wood filler paste to open-grain woods, as defined in "MPI Architectural Painting Specification Manual," to produce smooth, glasslike finish.

3.3 APPLICATION

- A. Apply finishes according to manufacturer's written instructions.
 1. Use applicators and techniques suited for finish and substrate indicated.
 2. Finish surfaces behind movable equipment and furniture same as similar exposed surfaces.
- B. Apply finishes to produce surface films without cloudiness, holidays, lap marks, brush marks, runs, ropiness, or other surface imperfections.

3.4 FIELD QUALITY CONTROL

- A. Owner reserves the right to invoke the following procedure at any time and as often as Owner deems necessary during the period when finishes are being applied:
 1. Owner will engage the services of a qualified testing agency to sample finish materials being used. Samples of material delivered to Project site will be taken, identified, sealed, and certified in presence of Contractor.
 2. Testing agency will perform tests for compliance with product requirements.

3. Owner may direct Contractor to stop applying finishes if test results show materials being used do not comply with product requirements. Contractor shall remove noncomplying materials from Project site, pay for testing, and refinish surfaces finished with rejected materials. Contractor will be required to remove rejected materials from previously finished surfaces if, on refinishing with complying materials, the two finishes are incompatible.

3.5 CLEANING AND PROTECTION

- A. At end of each workday, remove rubbish, empty cans, rags, and other discarded materials from Project site.
- B. After completing finish application, clean spattered surfaces. Remove spattered materials by washing, scraping, or other methods. Do not scratch or damage adjacent finished surfaces.
- C. Protect work of other trades against damage from finish application. Correct damage by cleaning, repairing, replacing, and refinishing, as approved by Architect, and leave in an undamaged condition.
- D. At completion of construction activities of other trades, touch up and restore damaged or defaced finished wood surfaces.

3.6 INTERIOR WOOD-FINISH-SYSTEM SCHEDULE

- A. Exposed Glue-Laminated Beam and Column Substrates:
 1. Polyurethane Varnish Over Stain System: MPI INT 6.1J.
 - a. Stain Coat: Interior wood stain (semitransparent).
 - b. Three Finish Coats: Interior, oil-modified, clear urethane (satin).
- B. Finish Carpentry Substrates:
 1. Polyurethane Varnish Over Stain System: MPI INT 6.3E.
 - a. Stain Coat: Interior wood stain (semitransparent).
 - b. Intermediate coat: Fire retardant treatment.
 - c. Three Finish Coats: Interior, oil-modified, clear urethane .
- C. Exposed Wood Panel-Product Substrates:
 1. Polyurethane Varnish Over Stain System: MPI INT 6.4E.
 - a. Stain Coat: Interior wood stain (semitransparent).
 - b. Intermediate coat: Fire retardant treatment.
 - c. Three Finish Coats: Interior, oil-modified, clear urethane .

END OF SECTION 099300

SECTION 101423 - PANEL SIGNAGE

PART 1 - GENERAL

1.1 RELATED DOCUMENTS

- A. Drawings and general provisions of the Contract, including General and Supplementary Conditions and Division 01 Specification Sections, apply to this Section.

1.2 SUMMARY

- A. Section Includes:
 - 1. Panel signs.

1.3 DEFINITIONS

- A. Accessible: In accordance with the accessibility standard.

1.4 COORDINATION

- A. Furnish templates for placement of sign-anchorage devices embedded in permanent construction by other installers.

1.5 ACTION SUBMITTALS

- A. Product Data: For each type of product.
- B. Shop Drawings: For panel signs.
 - 1. Include fabrication and installation details and attachments to other work.
 - 2. Show sign mounting heights, locations of supplementary supports to be provided by others, and accessories.
 - 3. Show message list, typestyles, graphic elements, including raised characters and Braille, and layout for each sign at least half size.
- C. Samples for Verification: For each type of sign assembly showing all components and with the required finish(es), in manufacturer's standard size unless otherwise indicated and as follows:
 - 1. Panel Signs: Not less than 12 inches square, including corner.
 - 2. Variable Component Materials: Full-size Sample of each base material, character (letter, number, and graphic element) in each exposed color and finish not included in Samples above.
 - 3. Exposed Accessories: Full-size Sample of each accessory type.

1.6 INFORMATIONAL SUBMITTALS

- A. Qualification Data: For Installer.

1.7 QUALITY ASSURANCE

- A. Installer Qualifications: Manufacturer of products.

1.8 FIELD CONDITIONS

- A. Field Measurements: Verify locations of anchorage devices embedded in permanent construction by other installers by field measurements before fabrication, and indicate measurements on Shop Drawings.

1.9 WARRANTY

- A. Special Warranty: Manufacturer agrees to repair or replace components of signs that fail in materials or workmanship within specified warranty period.

1. Failures include, but are not limited to, the following:
 - a. Deterioration of finishes beyond normal weathering.
 - b. Deterioration of embedded graphic image.
 - c. Separation or delamination of sheet materials and components.
2. Warranty Period: Five years from date of Substantial Completion.

PART 2 - PRODUCTS

2.1 PANEL SIGNS, GENERAL

- A. Regional Materials: Panel signs shall be manufactured within 500 miles of Project site.

2.2 PERFORMANCE REQUIREMENTS

- A. Accessibility Standard: Comply with applicable provisions in ICC A117.1 for signs.

2.3 SIGNS

- A. Manufacturers: Subject to compliance with requirements, provide products by one of the following:
- B. Basis-of-Design Product: Subject to compliance with requirements, provide product indicated or comparable product by one of the following:
1. Commercial Engraving; 29 Pelham Davis Circle, Greenville, SC. 29615
 2. Garfield Signs & Graphics; 203 Ford Street, Greer, SC. 29650
 3. Hilton Displays; 125 Hillside Drive, Greenville, SC. 29607
- C. Interior Panel Signs: Provide smooth sign panel surfaces constructed to remain flat under installed conditions within a tolerance of plus or minus 1/16 inch measured diagonally from corner to corner complying with the following requirements:
1. Acrylic Sheet: 1/4 inch thick.
 2. Edge Condition: Square cut.

3. Corner Condition: Rounded to radius indicated.
4. Mounting: Framed.
 - a. Wall mounted with
 - b. Manufacturer's standard anchors for substrates encountered
5. Color: As selected by Architect from manufacturer's full range.
6. Tactile Characters: Characters and Grade 2 Braille raised 1/32 inch above surface with contrasting characters.

D. Room-Identification Sign : Sign with smooth, uniform surfaces; with message and characters having uniform faces, sharp corners, and precisely formed lines and profiles; and as follows:

1. Laminated-Sheet Sign: Sandblasted polymer face sheet with raised graphics laminated over subsurface graphics to acrylic backing sheet to produce composite sheet.
 - a. Color(s): Match Architect's sample.
2. Mounting: Surface mounted to wall with concealed anchors .

2.4 ACCESSORIES

- A. Fasteners and Anchors: Manufacturer's standard as required for secure anchorage of signage, noncorrosive and compatible with each material joined, and complying with the following:
1. For exterior exposure, furnish nonferrous-metal or hot-dip galvanized devices unless otherwise indicated.
 2. Inserts: Furnish inserts to be set by other trades into concrete or masonry work.

2.5 FABRICATION

- A. General: Provide manufacturer's standard sign assemblies according to requirements indicated.
1. Preassemble signs and assemblies in the shop to greatest extent possible. Disassemble signs and assemblies only as necessary for shipping and handling limitations. Clearly mark units for reassembly and installation; apply markings in locations concealed from view after final assembly.
 2. Mill joints to a tight, hairline fit. Form assemblies and joints exposed to weather to resist water penetration and retention.
 3. Comply with AWS for recommended practices in welding and brazing. Provide welds and brazes behind finished surfaces without distorting or discoloring exposed side. Clean exposed welded and brazed connections of flux, and dress exposed and contact surfaces.
 4. Conceal connections if possible; otherwise, locate connections where they are inconspicuous.

2.6 GENERAL FINISH REQUIREMENTS

- A. Protect mechanical finishes on exposed surfaces from damage by applying a strippable, temporary protective covering before shipping.
- B. Appearance of Finished Work: Noticeable variations in same piece are not acceptable. Variations in appearance of adjoining components are acceptable if they are within the range of approved Samples and are assembled or installed to minimize contrast.

- C. Comply with NAAMM's "Metal Finishes Manual for Architectural and Metal Products" for recommendations for applying and designating finishes.

PART 3 - EXECUTION

3.1 EXAMINATION

- A. Examine substrates, areas, and conditions, with Installer present, for compliance with requirements for installation tolerances and other conditions affecting performance of signage work.
- B. Verify that sign-support surfaces are within tolerances to accommodate signs without gaps or irregularities between backs of signs and support surfaces unless otherwise indicated.
- C. Proceed with installation only after unsatisfactory conditions have been corrected.

3.2 INSTALLATION

- A. General: Install signs using mounting methods indicated and according to manufacturer's written instructions.
 - 1. Install signs level, plumb, true to line, and at locations and heights indicated, with sign surfaces free of distortion and other defects in appearance.
 - 2. Install signs so they do not protrude or obstruct according to the accessibility standard.
 - 3. Before installation, verify that sign surfaces are clean and free of materials or debris that would impair installation.
 - 4. Interior Wall Sign: Install signs on walls adjacent to latch side of door where applicable. Where not indicated or possible, such as double doors, install signs on nearest adjacent walls. Locate to allow approach within 3 inches of sign without encountering protruding objects or standing within swing of door.
- B. Wall-Mounted Signs: Comply with sign manufacturer's written instructions except where more stringent requirements apply.
 - 1. Mechanical Fasteners: Use nonremovable mechanical fasteners placed through the predrilled holes. Attach signs with fasteners and anchors suitable for secure attachment to substrate as recommended by sign manufacturer.
- C. Dimensional Characters: Mount Characters using standard fastening methods to comply with manufacturer's written instructions for character form, type of mounting, wall construction, and condition of exposure indicated. Provide heavy paper template to establish character spacing and to locate holes for fasteners.
 - 1. Flush Mounting: Mount characters with backs in contact with wall surface. Room name and number signs shall be mounted to the strike side of the door, rather than the door itself, and centered approximately 5'-0" above the floor. Where there is no wall adjacent to the strike side of the door, the signs may be located on the doors.

3.3 ADJUSTING AND CLEANING

- A. Remove and replace damaged or deformed signs and signs that do not comply with specified requirements. Replace signs with damaged or deteriorated finishes or components that cannot be successfully repaired by finish touchup or similar minor repair procedures.

- B. Remove temporary protective coverings and strippable films as signs are installed.
- C. On completion of installation, clean exposed surfaces of signs according to manufacturer's written instructions, and touch up minor nicks and abrasions in finish. Maintain signs in a clean condition during construction and protect from damage until acceptance by Owner.

3.4 SCHEDULE OF SIGN TYPES

- A. Sign Type A: 8 by 8 inch plastic molded sign with raised lettering, Grade II Braille and graphics to meeting ADA requirements. (Signs not required an outdoor rooms)
 - 1. In addition to signs indicated on the signage schedule, provide the following sign:
 - a. Toilets: Signage should have MEN or WOMEN.
 - b. Mechanical rooms.
 - c. Electrical / Data rooms

END OF SECTION 101423

SECTION 102113 - TOILET COMPARTMENTS

PART 1 - GENERAL

1.1 RELATED DOCUMENTS

- A. Drawings and general provisions of the Contract, including General and Supplementary Conditions and Division 01 Specification Sections, apply to this Section.

1.2 SUMMARY

- A. Section Includes:
 - 1. Solid-polymer toilet compartments configured as toilet enclosures urinal screens.
- B. Related Sections:
 - 1. Section 102800 "Toilet, Bath, and Laundry Accessories" for toilet tissue dispensers, grab bars, purse shelves, and similar accessories.

1.3 ACTION SUBMITTALS

- A. Product Data: For each type of product indicated. Include construction details, material descriptions, dimensions of individual components and profiles, and finishes.
- B. Shop Drawings: For toilet compartments. Include plans, elevations, sections, details, and attachments to other work.
 - 1. Show locations of cutouts for compartment-mounted toilet accessories.
 - 2. Show locations of reinforcements for compartment-mounted grab bars.
 - 3. Show locations of centerlines of toilet fixtures.
- C. Samples for Verification: For the following products, in manufacturer's standard sizes unless otherwise indicated:
 - 1. Each type of material, color, and finish required for units, prepared on 6-inch- square Samples of same thickness and material indicated for Work.

1.4 CLOSEOUT SUBMITTALS

- A. Maintenance Data: For toilet compartments to include in maintenance manuals.

1.5 QUALITY ASSURANCE

- A. Comply with requirements in GSA's CID-A-A-60003, "Partitions, Toilets, Complete."
- B. Surface-Burning Characteristics: As determined by testing identical products according to ASTM E 84, or another standard acceptable to authorities having jurisdiction, by a qualified testing agency. Identify products with appropriate markings of applicable testing agency.

1. Flame-Spread Index: 25 or less.
 2. Smoke-Developed Index: 450 or less.
- C. Regulatory Requirements: Comply with applicable provisions in ICC/ANSI A117.1 for toilet compartments designated as accessible.

1.6 PROJECT CONDITIONS

- A. Field Measurements: Verify actual locations of toilet fixtures, walls, columns, ceilings, and other construction contiguous with toilet compartments by field measurements before fabrication.

PART 2 - PRODUCTS

2.1 MATERIALS

- A. Aluminum Castings: ASTM B 26/B 26M.
- B. Aluminum Extrusions: ASTM B 221.
- C. Stainless-Steel Sheet: ASTM A 666, Type 304, stretcher-leveled standard of flatness.
- D. Stainless-Steel Castings: ASTM A 743/A 743M.
- E. Zamac: ASTM B 86, commercial zinc-alloy die castings.

2.2 SOLID-POLYMER UNITS

- A. Basis-of-Design Product: Subject to compliance with requirements, provide product indicated on Drawings or comparable product by one of the following:
1. Accurate Partitions Corporation.
 2. Bradley Corporation; Mills Partitions.
 3. General Partitions Mfg. Corp. (Basis of Design)
 4. Hadrian Manufacturing Inc.
- B. Toilet-Enclosure Style: Overhead braced, Floor anchored.
- C. Urinal-Screen Style: Wall hung, Floor anchored, Overhead braced.
- D. Door, Panel, Screen, and Pilaster Construction: Solid, high-density polyethylene (HDPE) panel material, not less than 1 inch thick, seamless, with eased edges, no-sightline system, and with homogenous color and pattern throughout thickness of material.
1. Integral Hinges: Configure doors and pilasters to receive integral hinges.
 2. Heat-Sink Strip: Manufacturer's standard continuous, stainless-steel strip fastened to exposed bottom edges of solid-polymer components to prevent burning.
 3. Color and Pattern: One color and pattern in each room as selected by Architect from manufacturer's full range.
- E. Pilaster Shoes: Manufacturer's standard design; stainless steel.
1. Polymer Color and Pattern: Matching pilaster.

- F. Urinal-Screen Post: Manufacturer's standard post design of material matching the thickness and construction of pilasters; with shoe matching that on the pilaster.
- G. Brackets (Fittings):
 - 1. Stirrup Type: Ear or U-brackets, stainless steel.

2.3 ACCESSORIES

- A. Hardware and Accessories: Manufacturer's standard design, heavy-duty operating hardware and accessories.
 - 1. Material: Chrome-plated zamac.
 - 2. Hinges: Manufacturer's standard continuous, cam type that swings to a closed or partially open position.
 - 3. Latch and Keeper: Manufacturer's standard latch unit designed for emergency access and with combination rubber-faced door strike and keeper. Provide units that comply with regulatory requirements for accessibility at compartments designated as accessible.
 - 4. Coat Hook: Manufacturer's standard combination hook and rubber-tipped bumper, sized to prevent in-swinging door from hitting compartment-mounted accessories.
 - 5. Door Bumper: Manufacturer's standard rubber-tipped bumper at out-swinging doors.
 - 6. Door Pull: Manufacturer's standard unit at out-swinging doors that complies with regulatory requirements for accessibility. Provide units on both sides of doors at compartments designated as accessible.
- B. Overhead Bracing: Manufacturer's standard continuous, extruded-aluminum head rail with antigrip profile and in manufacturer's standard finish.
- C. Anchorages and Fasteners: Manufacturer's standard exposed fasteners of stainless steel or chrome-plated steel or brass, finished to match the items they are securing, with theft-resistant-type heads. Provide sex-type bolts for through-bolt applications. For concealed anchors, use stainless steel, hot-dip galvanized steel, or other rust-resistant, protective-coated steel.

2.4 FABRICATION

- A. Overhead-Braced Units: Provide manufacturer's standard corrosion-resistant supports, leveling mechanism, and anchors at pilasters to suit floor conditions. Provide shoes at pilasters to conceal supports and leveling mechanism.
- B. Floor-Anchored Units: Provide manufacturer's standard corrosion-resistant anchoring assemblies with leveling adjustment nuts at pilasters for structural connection to floor. Provide shoes at pilasters to conceal anchorage.
- C. Urinal-Screen Posts: Provide manufacturer's standard corrosion-resistant anchoring assemblies with leveling adjustment at [tops and] bottoms of posts. Provide shoes [and sleeves (caps)] at posts to conceal anchorage.
- D. Door Size and Swings: Unless otherwise indicated, provide 24-inch- wide, in-swinging doors for standard toilet compartments and 36-inch- wide, out-swinging doors with a minimum 32-inch- wide, clear opening for compartments designated as accessible.

PART 3 - EXECUTION

3.1 INSTALLATION

- A. General: Comply with manufacturer's written installation instructions. Install units rigid, straight, level, and plumb. Secure units in position with manufacturer's recommended anchoring devices.
1. Maximum Clearances:
 - a. Pilasters and Panels: 1/2 inch.
 - b. Panels and Walls: 1 inch.
 2. Stirrup Brackets: Secure panels to walls and to pilasters with no fewer than [two brackets attached] [three brackets attached at midpoint and] near top and bottom of panel.
 - a. Locate wall brackets so holes for wall anchors occur in masonry or tile joints.
 - b. Align brackets at pilasters with brackets at walls.
- B. Overhead-Braced Units: Secure pilasters to floor and level, plumb, and tighten. Set pilasters with anchors penetrating not less than 1-3/4 inches into structural floor unless otherwise indicated in manufacturer's written instructions. Secure continuous head rail to each pilaster with no fewer than two fasteners. Hang doors to align tops of doors with tops of panels, and adjust so tops of doors are parallel with overhead brace when doors are in closed position.
- C. Floor-Anchored Units: Set pilasters with anchors penetrating not less than 2 inches into structural floor unless otherwise indicated in manufacturer's written instructions. Level, plumb, and tighten pilasters. Hang doors and adjust so tops of doors are level with tops of pilasters when doors are in closed position.
- D. Urinal Screens: Attach with anchoring devices to suit supporting structure. Set units level and plumb, rigid, and secured to resist lateral impact.

3.2 ADJUSTING

- A. Hardware Adjustment: Adjust and lubricate hardware according to hardware manufacturer's written instructions for proper operation. Set hinges on in-swinging doors to hold doors open approximately 30 degrees from closed position when unlatched. Set hinges on out-swinging doors to return doors to fully closed position.

END OF SECTION 102113

SECTION 102800 - TOILET, BATH, AND LAUNDRY ACCESSORIES

PART 1 - GENERAL

1.1 RELATED DOCUMENTS

- A. Drawings and general provisions of the Contract, including General and Supplementary Conditions and Division 01 Specification Sections, apply to this Section.

1.2 SUMMARY

- A. Section Includes:

1. Public-use washroom accessories.

- B. Owner-Furnished Material:

1. TTD: Toilet Tissue Dispenser, Owner-Furnished.
2. PTD: Paper Towel Dispenser, Owner-Furnished.
3. SD: Soap Dispenser, Owner-Furnished.
4. WR: Waste receptacle, Owner-Furnished.

1.3 ACTION SUBMITTALS

- A. Product Data: For each type of product indicated. Include the following:

1. Construction details and dimensions.
2. Anchoring and mounting requirements, including requirements for cutouts in other work and substrate preparation.
3. Material and finish descriptions.
4. Features that will be included for Project.
5. Manufacturer's warranty.

- B. Product Schedule: Indicating types, quantities, sizes, and installation locations by room of each accessory required.

1. Identify locations using room designations indicated.
2. Identify products using designations indicated.

1.4 CLOSEOUT SUBMITTALS

- A. Maintenance Data: For toilet and bath accessories to include in maintenance manuals.

1.5 QUALITY ASSURANCE

- A. Source Limitations: For products listed together in the same Part 2 articles, obtain products from single source from single manufacturer.

- B. Electrical Components, Devices, and Accessories: Listed and labeled as defined in NFPA 70, by a qualified testing agency, and marked for intended location and application.

1.6 COORDINATION

- A. Coordinate accessory locations with other work to prevent interference with clearances required for access by people with disabilities, and for proper installation, adjustment, operation, cleaning, and servicing of accessories.
- B. Deliver inserts and anchoring devices set into concrete or masonry as required to prevent delaying the Work.

PART 2 - PRODUCTS

2.1 MATERIALS

- A. Stainless Steel: ASTM A 666, Type 304, 0.031-inch minimum nominal thickness unless otherwise indicated.
- B. Brass: ASTM B 19, flat products; ASTM B 16/B 16M, rods, shapes, forgings, and flat products with finished edges; or ASTM B 30, castings.
- C. Steel Sheet: ASTM A 1008/A 1008M, Designation CS (cold rolled, commercial steel), 0.036-inch minimum nominal thickness.
- D. Galvanized-Steel Sheet: ASTM A 653/A 653M, with G60 hot-dip zinc coating.
- E. Galvanized-Steel Mounting Devices: ASTM A 153/A 153M, hot-dip galvanized after fabrication.
- F. Fasteners: Screws, bolts, and other devices of same material as accessory unit and tamper-and-theft resistant where exposed, and of galvanized steel where concealed.
- G. Chrome Plating: ASTM B 456, Service Condition Number SC 2 (moderate service).
- H. ABS Plastic: Acrylonitrile-butadiene-styrene resin formulation.

2.2 PUBLIC-USE WASHROOM ACCESSORIES

- A. Manufacturers: Subject to compliance with requirements, provide products by one of the following:
 - 1. A & J Washroom Accessories, Inc.
 - 2. American Specialties, Inc.
 - 3. Bobrick Washroom Equipment, Inc.
 - 4. Bradley Corporation.
- B. Grab Bar (GB36), (GB42), (GB18) :
 - 1. Basis-of-Design Product: Bobrick Washroom Equipment; B-5806 series.
 - 2. Mounting: Flanges with concealed fasteners.
 - 3. Material: Stainless steel, 0.05 inch thick.

- a. Finish: Smooth, No. 4 finish (satin) on ends and slip-resistant texture in grip area.
 4. Outside Diameter: 1-1/2 inches .
 5. Configuration and Length: As indicated on Drawings, number designates length.
- C. Sanitary-Napkin Disposal Unit (SND):
1. Basis-of-Design Product: Bobrick Washroom Equipment; B-254 .
 2. Mounting: Surface mounted.
 3. Door or Cover: Self-closing, disposal-opening cover[and hinged face panel with tumbler lockset.
 4. Receptacle: Removable.
 5. Material and Finish: Stainless steel, No. 4 finish (satin).
- D. Mirror Unit (M1):
1. Basis-of-Design Product: Bobrick Washroom Equipment; B-165.
 2. Frame: Stainless-steel angle, 0.05 inch thick .
 - a. Corners: Manufacturer's standard.
 3. Hangers: Produce rigid, tamper- and theft-resistant installation, using method indicated below.
 - a. Wall bracket of galvanized steel, equipped with concealed locking devices requiring a special tool to remove.
 4. Size: M1 - 24"w. x 36"h
- E. Coat Hook (CH):
1. Basis-of-Design Product: Bobrick Washroom Equipment; B2116.

2.3 FABRICATION

- A. General: Fabricate units with tight seams and joints, and exposed edges rolled. Hang doors and access panels with full-length, continuous hinges. Equip units for concealed anchorage and with corrosion-resistant backing plates.
- B. Keys: Provide universal keys for internal access to accessories for servicing and resupplying. Provide minimum of six keys to Owner's representative.

PART 3 - EXECUTION

3.1 INSTALLATION

- A. Install accessories according to manufacturers' written instructions, using fasteners appropriate to substrate indicated and recommended by unit manufacturer. Install units level, plumb, and firmly anchored in locations and at heights indicated.
- B. Grab Bars: Install to withstand a downward load of at least 250 lbf, when tested according to ASTM F 446.

3.2 ADJUSTING AND CLEANING

- A. Adjust accessories for unencumbered, smooth operation. Replace damaged or defective items.
- B. Remove temporary labels and protective coatings.
- C. Clean and polish exposed surfaces according to manufacturer's written recommendations.

END OF SECTION 102800

SECTION 104413 - FIRE EXTINGUISHER CABINETS

PART 1 - GENERAL

1.1 RELATED DOCUMENTS

- A. Drawings and general provisions of the Contract, including General and Supplementary Conditions and Division 01 Specification Sections, apply to this Section.

1.2 SUMMARY

- A. Section Includes:
 - 1. Fire protection cabinets for the following:
 - a. Portable fire extinguishers.
- B. Related Sections:
 - 1. Division 10 Section "Fire Extinguishers."

1.3 ACTION SUBMITTALS

- A. Product Data: For each type of product indicated. Include construction details, material descriptions, dimensions of individual components and profiles, and finishes for fire protection cabinets.
 - 1. Fire Protection Cabinets: Include roughing-in dimensions, details showing mounting methods, relationships of box and trim to surrounding construction, door hardware, cabinet type, trim style, and panel style.
- B. Shop Drawings: For fire protection cabinets. Include plans, elevations, sections, details, and attachments to other work.
- C. Product Schedule: For fire protection cabinets. Coordinate final fire protection cabinet schedule with fire extinguisher schedule to ensure proper fit and function. Use same designations indicated on Drawings.

1.4 QUALITY ASSURANCE

- A. Fire-Rated, Fire Protection Cabinets: Listed and labeled to comply with requirements in ASTM E 814 for fire-resistance rating of walls where they are installed.

1.5 COORDINATION

- A. Coordinate size of fire protection cabinets to ensure that type and capacity of fire extinguishers indicated are accommodated.
- B. Coordinate sizes and locations of fire protection cabinets with wall depths.

1.6 SEQUENCING

- A. Apply vinyl lettering on field-painted, fire protection cabinets after painting is complete.

PART 2 - PRODUCTS

2.1 MATERIALS

- A. Cold-Rolled Steel Sheet: ASTM A 1008/A 1008M, Commercial Steel (CS), Type B.
- B. Stainless-Steel Sheet: ASTM A 666, Type 304.
- C. Tempered Break Glass: ASTM C 1048, Kind FT, Condition A, Type I, Quality q3, 1.5 mm thick.
- D. Transparent Acrylic Sheet: ASTM D 4802, Category A-1 (cell-cast sheet), 3 mm thick, with Finish 1 (smooth or polished).

2.2 FIRE PROTECTION CABINET "FEC"

- A. Cabinet Type: Suitable for fire extinguisher.
 - 1. Products: Subject to compliance with requirements, available products that may be incorporated into the Work include, but are not limited to, the following:
 - a. J. L. Industries, Inc. .
 - b. Larsen's Manufacturing Company; (Basis-of-Design) Vertical Duo Clear.
 - c. Potter Roemer LLC .
- B. Cabinet Construction: Nonrated.
 - 1. Fire-Rated Cabinets: Construct fire-rated cabinets with double walls fabricated from 0.0428-inch- thick, cold-rolled steel sheet lined with minimum 5/8-inch- thick, fire-barrier material. Provide factory-drilled mounting holes.
- C. Cabinet Material: Steel sheet.
- D. Recessed Cabinet: Cabinet box recessed in walls of sufficient depth to suit style of trim indicated.
 - 1. Exposed Flat Trim: One-piece combination trim and perimeter door frame overlapping surrounding wall surface with exposed trim face and wall return at outer edge (backbend).
- E. Semirecessed Cabinet: Cabinet box partially recessed in walls of sufficient depth to suit style of trim indicated; with one-piece combination trim and perimeter door frame overlapping surrounding wall surface with exposed trim face and wall return at outer edge (backbend). Provide where walls are of insufficient depth for recessed cabinets but are of sufficient depth to accommodate semirecessed cabinet installation.
 - 1. Rolled-Edge Trim: 2-1/2-inch backbend depth.
- F. Cabinet Trim Material: Steel sheet.
- G. Door Material: Steel sheet.
- H. Door Style: Vertical duo panel with frame.

- I. Door Glazing: Break glass.
- J. Door Hardware: Manufacturer's standard door-operating hardware of proper type for cabinet type, trim style, and door material and style indicated.
 - 1. Provide projecting door pull and friction latch.
 - 2. Provide manufacturer's standard hinge permitting door to open 180 degrees.
- K. Accessories:
 - 1. Mounting Bracket: Manufacturer's standard steel, designed to secure fire extinguisher to fire protection cabinet, of sizes required for types and capacities of fire extinguishers indicated, with plated or baked-enamel finish.
 - 2. Break-Glass Strike: Manufacturer's standard metal strike, complete with chain and mounting clip, secured to cabinet.
 - 3. Identification: Lettering complying with authorities having jurisdiction for letter style, size, spacing, and location. Locate as directed by Architect.
 - a. Identify fire extinguisher in fire protection cabinet with the words "FIRE EXTINGUISHER."
 - 1) Location: Applied to cabinet glazing.
 - 2) Application Process: Silk-screened, or Pressure-sensitive vinyl letters.
 - 3) Lettering Color: Red.
 - 4) Orientation: Vertical.
- L. Finishes:
 - 1. Manufacturer's standard baked-enamel paint for the following:
 - a. Exterior of cabinet , door, and trim except for those surfaces indicated to receive another finish.
 - b. Interior of cabinet and door.
 - 2. Steel: Baked enamel or powder coat.

2.3 FIRE PROTECTION CABINET "FEC-SS"

Refer to the tables at the end of the Evaluations in Division 10 Section "Fire Protection Specialties" for a list of manufacturers' products. Use these tables in combination with manufacturers' catalogs or product data to insert series, type, model, and designations of other characteristics.

Copy this article and re-edit for each product.

Insert number to complete drawing designation. Use these designations on Drawings to identify each product.

- A. Cabinet Type: Suitable for fire extinguisher.

See Editing Instruction No. 1 in the Evaluations in Division 10 Section "Fire Protection Specialties" for cautions about naming manufacturers and products. See Division 01 Section "Product Requirements."

1. Products: Subject to compliance with requirements, available products that may be incorporated into the Work include, but are not limited to, the following:
 - a. J. L. Industries, Inc. .
 - b. Larsen's Manufacturing Company; (Basis-of-Design) Vertical Duo Clear.
 - c. Potter Roemer LLC .

Second and third options in first paragraph below are available only for recessed and semirecessed cabinets.

- B. Cabinet Construction: Nonrated.

Retain subparagraph below for fire-rated cabinets. Modern Metal constructs its cabinets to allow gypsum board to be added in the field. Revise below if required.

1. Fire-Rated Cabinets: Construct fire-rated cabinets with double walls fabricated from 0.0428-inch- (1.1-mm-) thick, cold-rolled steel sheet lined with minimum 5/8-inch- (16-mm-) thick, fire-barrier material. Provide factory-drilled mounting holes.

Steel is typical material for fire protection cabinets and is required for fire-rated types. Surface-mounted cabinets can be fabricated to match door and trim materials.

- C. Cabinet Material: Stainless Steel sheet.

Retain subparagraph below if required for combination fire extinguisher/hose-valve cabinets.

Retain one of first three paragraphs below.

- D. Recessed Cabinet: Cabinet box recessed in walls of sufficient depth to suit style of trim indicated.
1. Trimless with Concealed Flange: Surface of surrounding wall finishes flush with exterior finished surface of cabinet frame and door, without overlapping trim attached to cabinet. Provide recessed flange, of same material as box, attached to box to act as drywall bead.

Coordinate cabinet trim material in first paragraph below with door construction. These materials are available for both nonrated and fire-rated cabinets. Delete if no trim.

- E. Door Material: Stainless-steel sheet.
- F. Door Style: Vertical duo panel with frame.

Delete first paragraph below if retaining only solid opaque panel in "Door Style" Paragraph above.

- G. Door Glazing: Break glass.

Retain one of two subparagraphs above if retaining acrylic sheet in "Door Glazing" Paragraph above; retain subparagraph below if retaining acrylic bubble in that paragraph.

- H. Door Hardware: Manufacturer's standard door-operating hardware of proper type for cabinet type, trim style, and door material and style indicated.

1. Provide projecting door pull and friction latch.

Continuous hinges in subparagraph below are most common. Concealed hinges are used for flush panel doors. Pivots are sometimes used for fully glazed, frameless acrylic doors; verify availability with manufacturers selected.

2. Provide manufacturer's standard hinge permitting door to open 180 degrees.

I. Accessories:

Delete first subparagraph below if not required for types of fire protection cabinets and extinguishers specified.

1. Mounting Bracket: Manufacturer's standard steel, designed to secure fire extinguisher to fire protection cabinet, of sizes required for types and capacities of fire extinguishers indicated, with plated or baked-enamel finish.

Retain first subparagraph below if retaining break glass, tempered break glass, or break bubble.

2. Break-Glass Strike: Manufacturer's standard metal strike, complete with chain and mounting clip, secured to cabinet.

First option in first subparagraph below eliminates need for break glass but is only available from a few manufacturers.

3. Identification: Lettering complying with authorities having jurisdiction for letter style, size, spacing, and location. Locate as directed by Architect.

- a. Identify fire extinguisher in fire protection cabinet with the words "FIRE EXTINGUISHER."

- 1) Location: Applied to cabinet glazing.

J. Application Process: Silk-screened, or Finishes:

1. Manufacturer's standard baked-enamel paint for the following:
 - a. Interior of cabinet and door.

Retain subparagraph above, or one of five subparagraphs below that match cabinet trim and door materials.

2. Stainless Steel: No. 4

2.4 FABRICATION

A. Fire Protection Cabinets: Provide manufacturer's standard box (tub) with trim, frame, door, and hardware to suit cabinet type, trim style, and door style indicated.

1. Weld joints and grind smooth.
2. Provide factory-drilled mounting holes.
3. Prepare doors and frames to receive locks.
4. Install door locks at factory.

B. Cabinet Doors: Fabricate doors according to manufacturer's standards, from materials indicated and coordinated with cabinet types and trim styles selected.

1. Fabricate door frames with tubular stiles and rails and hollow-metal design, minimum 1/2 inch thick.

2. Miter and weld perimeter door frames.

C. Cabinet Trim: Fabricate cabinet trim in one piece with corners mitered, welded, and ground smooth.

2.5 GENERAL FINISH REQUIREMENTS

- A. Comply with NAAMM's "Metal Finishes Manual for Architectural and Metal Products" for recommendations for applying and designating finishes.
- B. Protect mechanical finishes on exposed surfaces of fire protection cabinets from damage by applying a strippable, temporary protective covering before shipping.
- C. Finish fire protection cabinets after assembly.
- D. Appearance of Finished Work: Noticeable variations in same piece are not acceptable. Variations in appearance of adjoining components are acceptable if they are within the range of approved Samples and are assembled or installed to minimize contrast.

2.6 STEEL FINISHES

A. Baked-Enamel or Powder-Coat Finish: Immediately after cleaning and pretreating, apply manufacturer's standard two-coat, baked-on finish consisting of prime coat and thermosetting topcoat. Comply with coating manufacturer's written instructions for applying and baking to achieve a minimum dry film thickness of 2 mils.

1. Color and Gloss: As selected by Architect from manufacturer's full range.

2.7 STAINLESS-STEEL FINISHES

A. Polished Finishes: Grind and polish surfaces to produce uniform finish, free of cross scratches.

- 1. Run grain of directional finishes with long dimension of each piece.
- 2. When polishing is completed, passivate and rinse surfaces. Remove embedded foreign matter and leave surfaces chemically clean.
- 3. Directional Satin Finish: No. 4.

PART 3 - EXECUTION

3.1 EXAMINATION

- A. Examine walls and partitions for suitable framing depth and blocking where recessed and semirecessed cabinets will be installed.
- B. Proceed with installation only after unsatisfactory conditions have been corrected.

3.2 PREPARATION

- A. Prepare recesses for semirecessed fire protection cabinets as required by type and size of cabinet and trim style.

3.3 INSTALLATION

- A. General: Install fire protection cabinets in locations and at mounting heights indicated or, if not indicated, at heights indicated below:
 - 1. Fire Protection Cabinets: 54 inches above finished floor to top of cabinet.
- B. Fire Protection Cabinets: Fasten cabinets to structure, square and plumb.
 - 1. Unless otherwise indicated, provide recessed fire protection cabinets. If wall thickness is not adequate for recessed cabinets, provide semirecessed fire protection cabinets.
 - 2. Provide inside latch and lock for break-glass panels.
 - 3. Fasten mounting brackets to inside surface of fire protection cabinets, square and plumb.
- C. Identification: Apply vinyl lettering at locations indicated.

3.4 ADJUSTING AND CLEANING

- A. Remove temporary protective coverings and strippable films, if any, as fire protection cabinets are installed unless otherwise indicated in manufacturer's written installation instructions.
- B. Adjust fire protection cabinet doors to operate easily without binding. Verify that integral locking devices operate properly.
- C. On completion of fire protection cabinet installation, clean interior and exterior surfaces as recommended by manufacturer.
- D. Touch up marred finishes, or replace fire protection cabinets that cannot be restored to factory-finished appearance. Use only materials and procedures recommended or furnished by fire protection cabinet and mounting bracket manufacturers.
- E. Replace fire protection cabinets that have been damaged or have deteriorated beyond successful repair by finish touchup or similar minor repair procedures.

END OF SECTION 104413

SECTION 104416 - FIRE EXTINGUISHERS

PART 1 - GENERAL

1.1 RELATED DOCUMENTS

- A. Drawings and general provisions of the Contract, including General and Supplementary Conditions and Division 01 Specification Sections, apply to this Section.

1.2 SUMMARY

- A. Section includes portable, hand-carried fire extinguishers and mounting brackets for fire extinguishers.

1.3 ACTION SUBMITTALS

- A. Product Data: For each type of product indicated. Include rating and classification, material descriptions, dimensions of individual components and profiles, and finishes for fire extinguisher.
- B. Product Schedule: For fire extinguishers. Coordinate final fire extinguisher schedule with fire protection cabinet schedule to ensure proper fit and function. Use same designations indicated on Drawings.

1.4 CLOSEOUT SUBMITTALS

- A. Operation and Maintenance Data: For fire extinguishers to include in maintenance manuals.

1.5 QUALITY ASSURANCE

- A. NFPA Compliance: Fabricate and label fire extinguishers to comply with NFPA 10, "Portable Fire Extinguishers."
- B. Fire Extinguishers: Listed and labeled for type, rating, and classification by an independent testing agency acceptable to authorities having jurisdiction.

1.6 COORDINATION

- A. Coordinate type and capacity of fire extinguishers with fire protection cabinets to ensure fit and function.

1.7 WARRANTY

- A. Special Warranty: Manufacturer's standard form in which manufacturer agrees to repair or replace fire extinguishers that fail in materials or workmanship within specified warranty period.

- 1. Failures include, but are not limited to, the following:
 - a. Failure of hydrostatic test according to NFPA 10.

- b. Faulty operation of valves or release levers.
2. Warranty Period: Six years from date of Substantial Completion.

PART 2 - PRODUCTS

2.1 PORTABLE, HAND-CARRIED FIRE EXTINGUISHERS

- A. Fire Extinguishers: Type, size, and capacity for each indicated.
 1. Manufacturers: Subject to compliance with requirements, provide products by one of the following:
 - a. Ansul Incorporated; Tyco International Ltd.
 - b. J. L. Industries, Inc.; a division of Activar Construction Products Group.
 - c. Kidde Residential and Commercial Division; Subsidiary of Kidde plc.
 - d. Larsen's Manufacturing Company.
 - e. Potter Roemer LLC.
 - f. Pyro-Chem; Tyco Safety Products.
 2. Valves: Nickel-plated, polished brass body.
 3. Handles and Levers: Stainless steel.
 4. Instruction Labels: Include pictorial marking system complying with NFPA 10, Appendix B and bar coding for documenting fire extinguisher location, inspections, maintenance, and recharging.
- B. Multipurpose Dry-Chemical Type in Steel Container "FE-M": UL-rated 4-A:60-B:C, 10-lb nominal capacity, with monoammonium phosphate-based dry chemical in enameled-steel container.
- C. Carbon Dioxide Type "FE-CO2" Insert drawing designation: UL-rated 10-B:C, 10-lb nominal capacity, with carbon dioxide in manufacturer's standard enameled-metal container.

2.2 MOUNTING BRACKETS "FEB"

- A. Mounting Brackets: Manufacturer's standard galvanized steel, designed to secure fire extinguisher to wall or structure, of sizes required for types and capacities of fire extinguishers indicated, with plated or black baked-enamel finish.
 1. Manufacturers: Subject to compliance with requirements, available manufacturers offering products that may be incorporated into the Work include, but are not limited to, the following:
 - a. Ansul Incorporated; Tyco International Ltd.
 - b. J. L. Industries, Inc.; a division of Activar Construction Products Group.
 - c. Larsen's Manufacturing Company.
 - d. Potter Roemer LLC.
- B. Identification: Lettering complying with authorities having jurisdiction for letter style, size, spacing, and location. Locate as indicated by Architect.
 1. Identify bracket-mounted fire extinguishers with the words "FIRE EXTINGUISHER" in red letter decals applied to mounting surface.
 - a. Orientation: Vertical.

PART 3 - EXECUTION

3.1 EXAMINATION

- A. Examine fire extinguishers for proper charging and tagging.
 - 1. Remove and replace damaged, defective, or undercharged fire extinguishers.
- B. Proceed with installation only after unsatisfactory conditions have been corrected.

3.2 INSTALLATION

- A. General: Install fire extinguishers and mounting brackets in locations indicated and in compliance with requirements of authorities having jurisdiction.

END OF SECTION 104416

SECTION 122113

HORIZONTAL LOUVER BLINDS

PART 1 - GENERAL

1.1 RELATED DOCUMENTS

- A. Drawings and general provisions of the Contract, including General and Supplementary Conditions and Division 01 Specification Sections, apply to this Section.

1.2 SUMMARY

- A. This Section includes the following:
 - 1. Horizontal louver blinds with aluminum slats.

1.3 SUBMITTALS

- A. Product Data: For each type of product indicated.
- B. Shop Drawings: Show fabrication and installation details for horizontal louver blinds and locations.
- C. Samples for Initial Selection: For each type and color of horizontal louver blind indicated.
- D. Window Treatment Schedule: For horizontal louver blinds. Use same designations indicated on Drawings.

1.4 QUALITY ASSURANCE

- A. Source Limitations: Obtain horizontal louver blinds through one source from a single manufacturer.
- B. Fire-Test-Response Characteristics: Provide horizontal louver blinds with the fire-test-response characteristics indicated, as determined by testing identical products per test method indicated below by UL or another testing and inspecting agency acceptable to authorities having jurisdiction. Identify materials with appropriate markings of applicable testing and inspecting agency.
 - 1. Flame-Resistance Ratings: Passes NFPA 701.
- C. Product Standard: Provide horizontal louver blinds complying with WCSC A 100.1.

1.5 DELIVERY, STORAGE, AND HANDLING

- A. Deliver horizontal louver blinds in factory packages, marked with manufacturer and product name, fire-test-response characteristics, and location of installation using same designations indicated on Drawings and in a window treatment schedule.

1.6 PROJECT CONDITIONS

- A. Environmental Limitations: Do not install horizontal louver blinds until construction and wet and dirty finish work in spaces, including painting, is complete and dry and ambient temperature and humidity conditions are maintained at the levels indicated for Project when occupied for its intended use.
- B. Field Measurements: Where horizontal louver blinds are indicated to fit to other construction, verify dimensions of other construction by field measurements before fabrication and indicate measurements on Shop Drawings. Allow clearances for operable glazed units' operation hardware throughout the entire operating range. Notify Architect of discrepancies. Coordinate fabrication schedule with construction progress to avoid delaying the Work.

PART 2 - PRODUCTS

2.1 HORIZONTAL LOUVER BLINDS, ALUMINUM SLATS

- A. Available Products: Subject to compliance with requirements, products that may be incorporated into the Work include, but are not limited to, the following:
- B. Products: Subject to compliance with requirements, provide one of the following:
 - 1. Hunter Douglas.
 - 2. Levolor, a Newell Rubbermaid Company.
 - 3. Bali.
- C. Slats: Aluminum; alloy and temper recommended by producer for type of use and finish indicated; with crowned profile and radiused corners.
 - 1. Width: 1 inch.
 - 2. Thickness: Not less than 0.008 inch.
 - 3. Finish: One color.
 - a. Ionized Coating: Antistatic, dust-repellent, baked polyester finish.
 - b. Reflective Coating: Manufacturer's special coating enhancing the reflection of solar energy on the outside-facing slat surface.
- D. Headrail: Formed steel or extruded aluminum; long edges returned or rolled; fully enclosing operating mechanisms on three sides and end plugs and the following:
 - 1. Capacity: One blind per headrail.
 - 2. Integrated Headrail/Valance: Curved face.
 - 3. Light-blocking lower back lip.
 - 4. Tilt limiter with preselected degree settings.
- E. Bottom Rail: Formed-steel or extruded-aluminum tube, with plastic or metal capped ends bottom contoured for minimizing light gaps; with enclosed ladders and tapes to prevent contact with sill.
- F. Ladders: Evenly spaced to prevent long-term slat sag.
 - 1. For Blinds with Nominal Slat Width 1 Inch or Less: Braided string.
 - 2. For Blinds with Nominal Slat Width 1 Inch or More: Braided string.
- G. Lift Cords: Manufacturer's standard.

- H. Tilt Control: Enclosed worm-gear mechanism, slip clutch or detachable wand preventing over rotation, and linkage rod, and the following:
 - 1. Tilt Operation: Manual with clear plastic wand.
 - 2. Tilt: Full.
- I. Lift Operation: Manual, cord lock; locks pull cord to stop blind at any position in ascending or descending travel.
- J. Valance: Two slats.
 - 1. Finish Color Characteristics: Match color, texture, pattern, and gloss of slats.
- K. Mounting: As indicated, permitting easy removal and replacement without damaging blind or adjacent surfaces and finishes; with spacers and shims required for blind placement and alignment indicated.
 - 1. Provide intermediate support brackets if end support spacing exceeds spacing recommended by manufacturer for weight and size of blind.
- L. Colors, Textures, Patterns, and Gloss: As selected by Architect from manufacturer's full range.

2.2 HORIZONTAL LOUVER BLIND FABRICATION

- A. Concealed Components: Noncorrodible or corrosion-resistant-coated materials.
 - 1. Lift-and-Tilt Mechanisms: With permanently lubricated moving parts.
- B. Unit Sizes: Obtain units fabricated in sizes to fill window and other openings as follows, measured at 74 deg F:
 - 1. Blind Units Installed between (inside) Jambs: Width equal to 1/4 inch per side or 1/2 inch total, plus or minus 1/8 inch, less than jamb-to-jamb dimension of opening in which each blind is installed. Length equal to 1/4 inch, plus or minus 1/8 inch, less than head-to-sill dimension of opening in which each blind is installed.
- C. Installation Brackets: Designed for easy removal and reinstallation of blind, for supporting headrail and operating hardware, and for hardware position and blind mounting method indicated.
- D. Installation Fasteners: No fewer than two fasteners per bracket, fabricated from metal noncorrosive to blind hardware and adjoining construction; type designed for securing to supporting substrate; and supporting blinds and accessories under conditions of normal use.
- E. Color-Coated Finish:
 - 1. Metal: For components exposed to view, apply manufacturer's standard baked finish complying with manufacturer's written instructions for surface preparation including pretreatment, application, baking, and minimum dry film thickness.
- F. Component Color: Provide rails, cords, ladders, and exposed-to-view metal and plastic matching or coordinating with slat color, unless otherwise indicated.

PART 3 - EXECUTION

3.1 EXAMINATION

- A. Examine substrates, areas, and conditions, with Installer present, for compliance with requirements for installation tolerances, operational clearances, and other conditions affecting performance.
 - 1. Proceed with installation only after unsatisfactory conditions have been corrected.

3.2 INSTALLATION

- A. Install horizontal louver blinds level and plumb and aligned with adjacent units according to manufacturer's written instructions, and located so exterior slat edges in any position are not closer than 1 inch to interior face of glass. Install intermediate support as required to prevent deflection in headrail. Allow clearances between adjacent blinds and for operating glazed opening's operation hardware if any.
- B. Flush Mounted: Install horizontal louver blinds with slat edges flush with finish face of opening if slats are tilted open.

3.3 ADJUSTING

- A. Adjust horizontal louver blinds to operate smoothly, easily, safely, and free of binding or malfunction throughout entire operational range.

3.4 CLEANING AND PROTECTION

- A. Clean horizontal louver blind surfaces after installation, according to manufacturer's written instructions.
- B. Provide final protection and maintain conditions, in a manner acceptable to manufacturer and Installer, that ensure that horizontal louver blinds are without damage or deterioration at time of Substantial Completion.
- C. Replace damaged horizontal louver blinds that cannot be repaired, in a manner approved by Architect, before time of Substantial Completion.

END OF SECTION 122113

SECTION 21 1313 - FIRE-SUPPRESSION PIPING

PART 1 - GENERAL

1.1 SUMMARY

- A. This Section includes the following fire-suppression piping inside the building:
 - 1. Wet-pipe sprinkler systems.
- B. Related Sections include the following:
 - 1. Division 28 Section "Fire Alarm" for alarm devices not specified in this Section.

1.2 SYSTEM DESCRIPTIONS

- A. Wet-Pipe Sprinkler System: Automatic sprinklers are attached to piping containing water and that is connected to water supply. Water discharges immediately from sprinklers when they are opened. Sprinklers open when heat melts fusible link or destroys frangible device. Hose connections are included if indicated.

1.3 PERFORMANCE REQUIREMENTS

- A. Standard Piping System Component Working Pressure: Listed for at least 175 psig.
- B. Fire-suppression sprinkler system design shall be approved by authorities having jurisdiction.
 - 1. Margin of Safety for Available Water Flow and Pressure: 10 percent, including losses through water-service piping, valves, and backflow preventers.
 - 2. Sprinkler Occupancy Hazard Classifications:
 - a. Refer to drawings.
 - 3. Minimum Density for Automatic-Sprinkler Piping Design:
 - a. Light-Hazard Occupancy: 0.10 gpm/sq.ft. over 1500 sq. ft.
 - 4. Maximum Protection Area per Sprinkler:
 - a. Per NFPA 13
 - 5. Total Combined Hose-Stream Demand Requirement: According to NFPA 13, unless otherwise indicated:
 - a. Light-Hazard Occupancies: 100 gpm for 30 minutes.
- C. Seismic Performance: Fire-suppression piping shall be capable of withstanding the effects of earthquake motions determined according to NFPA 13.

1.4 SUBMITTALS

- A. Product Data: For each product indicated.
- B. Approved Sprinkler Piping Drawings: Working plans, prepared according to NFPA 13, that have been approved by authorities having jurisdiction, including hydraulic calculations, if applicable.
- C. Field test reports and certificates.
- D. Field quality-control test reports.

- E. Operation and maintenance data.

1.5 QUALITY ASSURANCE

- A. Installer Qualifications: Installer's responsibilities include designing, fabricating, and installing fire-suppression systems. Base calculations on fire pump test data shown on the drawings.
- B. NFPA Standards: Fire-suppression-system equipment, specialties, accessories, installation, and testing shall comply with the following:
 - 1. NFPA 13 (2010 Edition), "Installation of Sprinkler Systems."

PART 2 - PRODUCTS

2.1 MANUFACTURERS

- A. In other Part 2 articles where titles below introduce lists, the following requirements apply to product selection:
 - 1. Manufacturers: Subject to compliance with requirements, provide products by one of the manufacturers specified.

2.2 STEEL PIPE AND FITTINGS

- A. Threaded-End, Standard-Weight Steel Pipe: ASTM A 53/A 53M, ASTM A 135, or ASTM A 795, with factory- or field-formed threaded ends.
 - 1. Cast-Iron Threaded Flanges: ASME B16.1.
 - 2. Malleable-Iron Threaded Fittings: ASME B16.3.
 - 3. Gray-Iron Threaded Fittings: ASME B16.4.
 - 4. Steel Threaded Pipe Nipples: ASTM A 733, made of ASTM A 53/A 53M or ASTM A 106, Schedule 40, seamless steel pipe. Include ends matching joining method.
 - 5. Steel Threaded Couplings: ASTM A 865.
- B. Grooved-End, Standard-Weight Steel Pipe: ASTM A 53/A 53M, ASTM A 135, or ASTM A 795, with factory- or field-formed, square-cut- or roll-grooved ends.
 - 1. Grooved-Joint Piping Systems:
 - a. Manufacturers:
 - 1) Anvil International, Inc.
 - 2) National Fittings, Inc.
 - 3) Shurjoint Piping Products, Inc.
 - 4) Star Pipe Products; Star Fittings Div.
 - 5) Victaulic Co. of America.
 - 6) Ward Manufacturing.
 - b. Grooved-End Fittings: UL-listed, ASTM A 536, ductile-iron casting with OD matching steel-pipe OD.
 - c. Grooved-End-Pipe Couplings: UL 213 and AWWA C606, rigid pattern, unless otherwise indicated; gasketed fitting matching steel-pipe OD. Include ductile-iron housing with keys matching steel-pipe and fitting grooves, prelubricated rubber gasket listed for use with housing, and steel bolts and nuts.

2.3 SPRINKLER SPECIALTY FITTINGS

- A. Sprinkler specialty fittings shall be UL listed or FMG approved, with 175-psig minimum working-pressure rating, and made of materials compatible with piping.
- B. Outlet Specialty Fittings:
 - 1. Manufacturers:
 - a. Anvil International, Inc.
 - b. National Fittings, Inc.
 - c. Shurjoint Piping Products, Inc.
 - d. Star Pipe Products; Star Fittings Div.
 - e. Victaulic Co. of America.
 - 2. Mechanical-T and -Cross Fittings: UL 213, ductile-iron housing with gaskets, bolts and nuts, and threaded, locking-lug, or grooved outlets.
- C. Sprinkler Drain and Alarm Test Fittings: Cast- or ductile-iron body; with threaded or locking-lug inlet and outlet, test valve, and orifice and sight glass.
 - 1. Manufacturers:
 - a. Tyco
 - b. Viking Corp.
 - c. Victaulic Co. of America.
- D. Sprinkler Branch-Line Test Fittings: Brass body with threaded inlet, capped drain outlet, and threaded outlet for sprinkler.
 - 1. Manufacturers:
 - a. Elkhart Brass Mfg. Co., Inc.
 - b. Fire-End and Croker Corp.
 - c. Potter-Roemer; Fire-Protection Div.
- E. Sprinkler Inspector's Test Fitting: Cast- or ductile-iron housing with threaded inlet and drain outlet and sight glass.
 - 1. Manufacturers:
 - a. AGF Manufacturing Co.
 - b. Viking Corp.
 - c. G/J Innovations, Inc.
- F. Drop-Nipple Fittings: UL 1474, adjustable with threaded inlet and outlet, and seals.
 - 1. Manufacturers:
 - a. Viking Corp.
 - b. Aegis
 - c. Prior approved equal

2.4 SPRINKLERS

- A. Sprinklers shall be UL listed or FMG approved, with 175-psig minimum pressure rating.
- B. Manufacturers:
 - 1. Tyco.
 - 2. Globe Fire Sprinkler Corporation.
 - 3. Reliable Automatic Sprinkler Co., Inc.
 - 4. Victaulic Co. of America.
 - 5. Viking Corp.
 - 6. Prior approved equal

- C. Automatic Sprinklers: With heat-responsive element complying with the following:
 - 1. UL 199, for nonresidential applications.
 - 2. UL 1767, for early-suppression, fast-response applications.
- D. Sprinkler Types and Categories: Nominal 1/2-inch orifice for "Ordinary" temperature classification rating, unless otherwise indicated or required by application.
- E. Sprinkler types, features, and options as follows:
 - 1. Pendent sprinklers.
 - 2. Quick-response sprinklers.
 - 3. Semi-Recessed sprinklers, including escutcheon.
 - 4. Sidewall sprinklers.
 - 5. Upright sprinklers.
- F. Sprinkler Finishes: Chrome plated.
- G. Sprinkler Escutcheons: Materials, types, and finishes for the following sprinkler mounting applications. Escutcheons for concealed, flush, and recessed-type sprinklers are specified with sprinklers.
 - 1. Ceiling Mounting: Chrome-plated steel, 2 piece, with 1-inch vertical adjustment.
 - 2. Sidewall Mounting: Chrome-plated steel, one piece, flat.
- H. Sprinkler Guards: Wire-cage type, including fastening device for attaching to sprinkler.

PART 3 - EXECUTION

3.1 PIPING APPLICATIONS, GENERAL

- A. Flanges, flanged fittings, unions, nipples, and transition and special fittings with finish and pressure ratings same as or higher than system's pressure rating may be used in aboveground applications, unless otherwise indicated.

3.2 SPRINKLER SYSTEM PIPING APPLICATIONS

- A. NPS 1-1/2 and Smaller: Threaded-end, black, standard-weight steel pipe; cast- or malleable-iron threaded fittings; and threaded joints.
- B. NPS 2 and Larger: Grooved-end, black, standard-weight steel pipe; grooved-end fittings; grooved-end-pipe couplings; and grooved joints.

3.3 JOINT CONSTRUCTION

- A. Threaded Joints: Comply with NFPA 13 for pipe thickness and threads. Do not thread pipe smaller than NPS 8 (DN 200) with wall thickness less than Schedule 40 unless approved by authorities having jurisdiction and threads are checked by a ring gage and comply with ASME B1.20.1.
- B. Grooved Joints: Assemble joints with listed coupling and gasket, lubricant, and bolts.
 - 1. Ductile-Iron Pipe: Radius-cut-groove ends of piping. Use grooved-end fittings and grooved-end-pipe couplings.
 - 2. Steel Pipe: Square-cut or roll-groove piping as indicated. Use grooved-end fittings and rigid, grooved-end-pipe couplings, unless otherwise indicated.

3.4 PIPING INSTALLATION

- A. Locations and Arrangements: Drawing plans, schematics, and diagrams indicate general location and arrangement of piping. Install piping as indicated, as far as practical.
 - 1. Deviations from approved working plans for piping require written approval from authorities having jurisdiction. File written approval with Architect before deviating from approved working plans.
- B. Use approved fittings to make changes in direction, branch takeoffs from mains, and reductions in pipe sizes.
- C. Install unions adjacent to each valve in pipes NPS 2 and smaller. Unions are not required on flanged devices or in piping installations using grooved joints.
- D. Install flanges or flange adapters on valves, apparatus, and equipment having NPS 2-1/2 and larger connections.
- E. Install sprinkler piping with drains for complete system drainage.
- F. Hangers and Supports: Comply with NFPA 13 for hanger materials.
 - 1. Install sprinkler system piping according to NFPA 13.
- G. Earthquake Protection: Install piping according to NFPA 13 to protect from earthquake damage.
- H. Install pressure gages on riser or feed main, at each sprinkler test connection, and at top of each standpipe. Include pressure gages with connection not less than NPS 1/4 and with soft metal seated globe valve, arranged for draining pipe between gage and valve. Install gages to permit removal, and install where they will not be subject to freezing.
- I. Fill wet-pipe sprinkler system piping with water.

3.5 SPRINKLER APPLICATIONS

- A. Drawings indicate sprinkler types to be used. Where specific types are not indicated, use the following sprinkler types:
 - 1. Rooms with Suspended Ceilings: Recessed sprinklers.
 - 2. Sprinkler Finishes:
 - a. Recessed Sprinklers: Bright chrome, with bright chrome semi-recessed escutcheon.

3.6 SPRINKLER INSTALLATION

- A. Install sprinklers in suspended ceilings in center of acoustical ceiling panels and tiles. Sprinklers shall have hard pipe connections to sprinkler piping; flex connectors will not be allowed or accepted.
- B. Do not install pendent or sidewall, wet-type sprinklers in areas subject to freezing. Use dry-type sprinklers with water supply from heated space.

3.7 LABELING AND IDENTIFICATION

- A. Install labeling and pipe markers on equipment and piping according to requirements in NFPA 13 and in Division 23 Section "Mechanical Identification."

3.8 FIELD QUALITY CONTROL

- A. Perform the following field tests and inspections and prepare test reports:
 - 1. Leak Test: After installation, charge system and test for leaks. Repair leaks and retest until no leaks exist.
 - 2. Flush, test, and inspect sprinkler systems according to NFPA 13, "Systems Acceptance" Chapter.
 - 3. Coordinate with fire alarm tests. Operate as required.
 - 4. Verify that equipment hose threads are same as local fire department equipment.
- B. Report test results promptly and in writing to Architect and authorities having jurisdiction.

END OF SECTION 21 1313

SECTION 22 0500 - COMMON WORK RESULTS FOR PLUMBING

PART 1 - GENERAL

1.1 RELATED DOCUMENTS

- A. Drawings and general provisions of the Contract, including General and Supplementary Conditions and Division 01 Specification Sections, apply to this Section.

1.2 SUMMARY

- A. This Section includes the following:
 1. Piping materials and installation instructions common to most piping systems.
 2. Transition fittings.
 3. Dielectric fittings.
 4. Mechanical sleeve seals.
 5. Sleeves.
 6. Escutcheons.
 7. Grout.
 8. Plumbing demolition.
 9. Equipment installation requirements common to equipment sections.
 10. Painting and finishing.
 11. Concrete bases.
 12. Supports and anchorages.

1.3 DEFINITIONS

- A. Finished Spaces: Spaces other than mechanical and electrical equipment rooms, furred spaces, pipe chases, unheated spaces immediately below roof, spaces above ceilings, unexcavated spaces, crawlspaces, and tunnels.
- B. Exposed, Interior Installations: Exposed to view indoors. Examples include finished occupied spaces and mechanical equipment rooms.
- C. Exposed, Exterior Installations: Exposed to view outdoors or subject to outdoor ambient temperatures and weather conditions. Examples include rooftop locations.
- D. Concealed, Interior Installations: Concealed from view and protected from physical contact by building occupants. Examples include above ceilings and in chases.
- E. Concealed, Exterior Installations: Concealed from view and protected from weather conditions and physical contact by building occupants but subject to outdoor ambient temperatures. Examples include installations within unheated shelters.
- F. The following are industry abbreviations for plastic materials:
 1. ABS: Acrylonitrile-butadiene-styrene plastic.
 2. CPVC: Chlorinated polyvinyl chloride plastic.
 3. PE: Polyethylene plastic.
 4. PVC: Polyvinyl chloride plastic.
- G. The following are industry abbreviations for rubber materials:
 1. EPDM: Ethylene-propylene-diene terpolymer rubber.
 2. NBR: Acrylonitrile-butadiene rubber.

1.4 SUBMITTALS

- A. Product Data: For the following:
 - 1. Transition fittings.
 - 2. Dielectric fittings.
 - 3. Mechanical sleeve seals.
 - 4. Escutcheons.
- B. Welding certificates.

1.5 QUALITY ASSURANCE

- A. Steel Support Welding: Qualify processes and operators according to AWS D1.1, "Structural Welding Code--Steel."
- B. Steel Pipe Welding: Qualify processes and operators according to ASME Boiler and Pressure Vessel Code: Section IX, "Welding and Brazing Qualifications."
 - 1. Comply with provisions in ASME B31 Series, "Code for Pressure Piping."
 - 2. Certify that each welder has passed AWS qualification tests for welding processes involved and that certification is current.
- C. Electrical Characteristics for Plumbing Equipment: Equipment of higher electrical characteristics may be furnished provided such proposed equipment is approved in writing and connecting electrical services, circuit breakers, and conduit sizes are appropriately modified. If minimum energy ratings or efficiencies are specified, equipment shall comply with requirements.

1.6 DELIVERY, STORAGE, AND HANDLING

- A. Deliver pipes and tubes with factory-applied end caps. Maintain end caps through shipping, storage, and handling to prevent pipe end damage and to prevent entrance of dirt, debris, and moisture.
- B. Store plastic pipes protected from direct sunlight. Support to prevent sagging and bending.

1.7 COORDINATION

- A. Arrange for pipe spaces, chases, slots, and openings in building structure during progress of construction, to allow for plumbing installations.
- B. Coordinate installation of required supporting devices and set sleeves in poured-in-place concrete and other structural components as they are constructed.
- C. Coordinate requirements for access panels and doors for plumbing items requiring access that are concealed behind finished surfaces. Access panels and doors are specified in Division 08 Section "Access Doors and Frames."

PART 2 - PRODUCTS

2.1 MANUFACTURERS

- A. In other Part 2 articles where subparagraph titles below introduce lists, the following requirements apply for product selection:
 - 1. Manufacturers: Subject to compliance with requirements, provide products by the manufacturers specified.

2.2 PIPE, TUBE, AND FITTINGS

- A. Refer to individual Division 22 piping Sections for pipe, tube, and fitting materials and joining methods.
- B. Pipe Threads: ASME B1.20.1 for factory-threaded pipe and pipe fittings.

2.3 JOINING MATERIALS

- A. Refer to individual Division 22 piping Sections for special joining materials not listed below.
- B. Pipe-Flange Gasket Materials: Suitable for chemical and thermal conditions of piping system contents.
 - 1. ASME B16.21, nonmetallic, flat, asbestos-free, 1/8-inch maximum thickness unless thickness or specific material is indicated.
 - a. Full-Face Type: For flat-face, Class 125, cast-iron and cast-bronze flanges.
 - b. Narrow-Face Type: For raised-face, Class 250, cast-iron and steel flanges.
 - 2. AWWA C110, rubber, flat face, 1/8 inch thick, unless otherwise indicated; and full-face or ring type, unless otherwise indicated.
- C. Flange Bolts and Nuts: ASME B18.2.1, carbon steel, unless otherwise indicated.
- D. Plastic, Pipe-Flange Gasket, Bolts, and Nuts: Type and material recommended by piping system manufacturer, unless otherwise indicated.
- E. Solder Filler Metals: ASTM B 32, lead-free alloys. Include water-flushable flux according to ASTM B 813.
- F. Brazing Filler Metals: AWS A5.8, BCuP Series, copper-phosphorus alloys for general-duty brazing, unless otherwise indicated; and AWS A5.8, BAg1, silver alloy for refrigerant piping, unless otherwise indicated.
- G. Welding Filler Metals: Comply with AWS D10.12 for welding materials appropriate for wall thickness and chemical analysis of steel pipe being welded.
- H. Solvent Cements for Joining Plastic Piping:
 - 1. ABS Piping: ASTM D 2235.
 - 2. CPVC Piping: ASTM F 493.
 - 3. PVC Piping: ASTM D 2564. Include primer according to ASTM F 656.
 - 4. PVC to ABS Piping Transition: ASTM D 3138.
- I. Fiberglass Pipe Adhesive: As furnished or recommended by pipe manufacturer.

2.4 TRANSITION FITTINGS

- A. AWWA Transition Couplings: Same size as, and with pressure rating at least equal to and with ends compatible with, piping to be joined.
 - 1. Manufacturers:
 - a. Cascade Waterworks Mfg. Co.
 - b. Dresser Industries, Inc.; DMD Div.
 - c. Ford Meter Box Company, Incorporated (The); Pipe Products Div.
 - d. JCM Industries.
 - e. Smith-Blair, Inc.
 - f. Viking Johnson.
 - 2. Underground Piping NPS 1-1/2 and Smaller: Manufactured fitting or coupling.
 - 3. Underground Piping NPS 2 and Larger: AWWA C219, metal sleeve-type coupling.
 - 4. Aboveground Pressure Piping: Pipe fitting.
- B. Plastic-to-Metal Transition Fittings: PVC one-piece fitting with manufacturer's Schedule 80 equivalent dimensions; one end with threaded brass insert, and one solvent-cement-joint end.
 - 1. Manufacturers:

- a. Eslon Thermoplastics.
 - b. Prior Approved Equal
- C. Plastic-to-Metal Transition Adaptors: One-piece fitting with manufacturer's SDR 11 equivalent dimensions; one end with threaded brass insert, and one solvent-cement-joint end.
- 1. Manufacturers:
 - a. Thompson Plastics, Inc.
 - b. Prior Approved Equal
- D. Plastic-to-Metal Transition Unions: MSS SP-107, PVC four-part union. Include brass end, solvent-cement-joint end, rubber O-ring, and union nut.
- 1. Manufacturers:
 - a. NIBCO INC.
 - b. NIBCO, Inc.; Chemtrol Div.

2.5 DIELECTRIC FITTINGS

- A. Description: Combination fitting of copper alloy and ferrous materials with threaded, solder-joint, plain, or weld-neck end connections that match piping system materials.
- B. Insulating Material: Suitable for system fluid, pressure, and temperature.
- C. Dielectric Unions: Factory-fabricated, union assembly, for 250-psig minimum working pressure at 180 deg F.
- 1. Manufacturers:
 - a. Capitol Manufacturing Co.
 - b. Central Plastics Company.
 - c. Eclipse, Inc.
 - d. Epco Sales, Inc.
 - e. Hart Industries, International, Inc.
 - f. Watts Industries, Inc.; Water Products Div.
 - g. Zurn Industries, Inc.; Wilkins Div.
- D. Dielectric Flanges: Factory-fabricated, companion-flange assembly, for 150- or 300-psig minimum working pressure as required to suit system pressures.
- 1. Manufacturers:
 - a. Capitol Manufacturing Co.
 - b. Central Plastics Company.
 - c. Epco Sales, Inc.
 - d. Watts Industries, Inc.; Water Products Div.
- E. Dielectric-Flange Kits: Companion-flange assembly for field assembly. Include flanges, full-face- or ring-type neoprene or phenolic gasket, phenolic or polyethylene bolt sleeves, phenolic washers, and steel backing washers.
- 1. Manufacturers:
 - a. Advance Products & Systems, Inc.
 - b. Calpico, Inc.
 - c. Central Plastics Company.
 - d. Pipeline Seal and Insulator, Inc.
 - 2. Separate companion flanges and steel bolts and nuts shall have 150- or 300-psig minimum working pressure where required to suit system pressures.
- F. Dielectric Couplings: Galvanized-steel coupling with inert and noncorrosive, thermoplastic lining; threaded ends; and 300-psig minimum working pressure at 225 deg F.
- 1. Manufacturers:
 - a. Calpico, Inc.
 - b. Lochinvar Corp.

- G. Dielectric Nipples: Electroplated steel nipple with inert and noncorrosive, thermoplastic lining; plain, threaded, or grooved ends; and 300-psig minimum working pressure at 225 deg F.
 - 1. Manufacturers:
 - a. Perfection Corp.
 - b. Precision Plumbing Products, Inc.
 - c. Sioux Chief Manufacturing Co., Inc.
 - d. Victaulic Co. of America.

2.6 MECHANICAL SLEEVE SEALS

- A. Description: Modular sealing element unit, designed for field assembly, to fill annular space between pipe and sleeve.
 - 1. Manufacturers:
 - a. Advance Products & Systems, Inc.
 - b. Calpico, Inc.
 - c. Metraflex Co.
 - d. Pipeline Seal and Insulator, Inc.
 - 2. Sealing Elements: EPDM interlocking links shaped to fit surface of pipe. Include type and number required for pipe material and size of pipe.
 - 3. Pressure Plates: Stainless steel. Include two for each sealing element.
 - 4. Connecting Bolts and Nuts: Stainless steel of length required to secure pressure plates to sealing elements. Include one for each sealing element.

2.7 SLEEVES

- A. Galvanized-Steel Sheet: 0.0239-inch minimum thickness; round tube closed with welded longitudinal joint.
- B. Steel Pipe: ASTM A 53, Type E, Grade B, Schedule 40, galvanized, plain ends.
- C. Cast Iron: Cast or fabricated "wall pipe" equivalent to ductile-iron pressure pipe, with plain ends and integral waterstop, unless otherwise indicated.
- D. Stack Sleeve Fittings: Manufactured, cast-iron sleeve with integral clamping flange. Include clamping ring and bolts and nuts for membrane flashing.
 - 1. Underdeck Clamp: Clamping ring with set screws.
- E. Molded PVC: Permanent, with nailing flange for attaching to wooden forms.
- F. PVC Pipe: ASTM D 1785, Schedule 40.
- G. Molded PE: Reusable, PE, tapered-cup shaped, and smooth-outer surface with nailing flange for attaching to wooden forms.

2.8 ESCUTCHEONS

- A. Description: Manufactured wall and ceiling escutcheons and floor plates, with an ID to closely fit around pipe, tube, and insulation of insulated piping and an OD that completely covers opening.
- B. One-Piece, Deep-Pattern Type: Deep-drawn, box-shaped brass with polished chrome-plated finish.
- C. One-Piece, Cast-Brass Type: With set screw.
 - 1. Finish: Polished chrome-plated.
- D. Split-Casting, Cast-Brass Type: With concealed hinge and set screw.
 - 1. Finish: Polished chrome-plated.

- E. One-Piece, Stamped-Steel Type: With spring clips and chrome-plated finish.
- F. Split-Plate, Stamped-Steel Type: With concealed hinge, spring clips, and chrome-plated finish.
- G. One-Piece, Floor-Plate Type: Cast-iron floor plate.
- H. Split-Casting, Floor-Plate Type: Cast brass with concealed hinge and set screw.

2.9 GROUT

- A. Description: ASTM C 1107, Grade B, nonshrink and nonmetallic, dry hydraulic-cement grout.
 - 1. Characteristics: Post-hardening, volume-adjusting, nonstaining, noncorrosive, nongaseous, and recommended for interior and exterior applications.
 - 2. Design Mix: 5000-psi, 28-day compressive strength.
 - 3. Packaging: Premixed and factory packaged.

PART 3 - EXECUTION

3.1 PIPING SYSTEMS - COMMON REQUIREMENTS

- A. Install piping according to the following requirements and Division 22 Sections specifying piping systems.
- B. Drawing plans, schematics, and diagrams indicate general location and arrangement of piping systems. Indicated locations and arrangements were used to size pipe and calculate friction loss, expansion, pump sizing, and other design considerations. Install piping as indicated unless deviations to layout are approved on Coordination Drawings.
- C. Install piping in concealed locations, unless otherwise indicated and except in equipment rooms and service areas.
- D. Install piping indicated to be exposed and piping in equipment rooms and service areas at right angles or parallel to building walls. Diagonal runs are prohibited unless specifically indicated otherwise.
- E. Install piping above accessible ceilings to allow sufficient space for ceiling panel removal.
- F. Install piping to permit valve servicing.
- G. Install piping at indicated slopes.
- H. Install piping free of sags and bends.
- I. Install fittings for changes in direction and branch connections.
- J. Install piping to allow application of insulation.
- K. Select system components with pressure rating equal to or greater than system operating pressure.
- L. Install escutcheons for penetrations of walls, ceilings, and floors according to the following:
 - 1. New Piping:
 - a. Piping with Fitting or Sleeve Protruding from Wall: One-piece, deep-pattern type.
 - b. Chrome-Plated Piping: One-piece, cast-brass type with polished chrome-plated finish.
 - c. Insulated Piping: One-piece, stamped-steel type with spring clips.
 - d. Bare Piping at Wall and Floor Penetrations in Finished Spaces: One-piece, cast-brass type with polished chrome-plated finish.

- e. Bare Piping at Wall and Floor Penetrations in Finished Spaces: One-piece, stamped-steel type.
 - f. Bare Piping at Ceiling Penetrations in Finished Spaces: One-piece, cast-brass type with polished chrome-plated finish.
 - g. Bare Piping in Unfinished Service Spaces: One-piece, cast-brass type with polished chrome-plated finish.
 - h. Bare Piping in Equipment Rooms: One-piece, cast-brass type.
 - i. Bare Piping at Floor Penetrations in Equipment Rooms: One-piece, floor-plate type.
- M. Sleeves are not required for core-drilled holes.
- N. Permanent sleeves are not required for holes formed by removable PE sleeves.
- O. Install sleeves for pipes passing through concrete and masonry walls and concrete floor and roof slabs.
- P. Install sleeves for pipes passing through concrete and masonry walls, gypsum-board partitions, and concrete floor and roof slabs.
- 1. Cut sleeves to length for mounting flush with both surfaces.
 - a. Exception: Extend sleeves installed in floors of mechanical equipment areas or other wet areas 2 inches above finished floor level. Extend cast-iron sleeve fittings below floor slab as required to secure clamping ring if ring is specified.
 - 2. Install sleeves in new walls and slabs as new walls and slabs are constructed.
 - 3. Install sleeves that are large enough to provide 1/4-inch annular clear space between sleeve and pipe or pipe insulation. Use the following sleeve materials:
 - a. Steel Pipe Sleeves: For pipes smaller than NPS 6.
 - b. Steel Sheet Sleeves: For pipes NPS 6 and larger, penetrating gypsum-board partitions.
 - c. Stack Sleeve Fittings: For pipes penetrating floors with membrane waterproofing. Secure flashing between clamping flanges. Install section of cast-iron soil pipe to extend sleeve to 2 inches above finished floor level. Refer to Division 07 Section "Sheet Metal Flashing and Trim" for flashing.
 - 1) Seal space outside of sleeve fittings with grout.
 - 4. Except for underground wall penetrations, seal annular space between sleeve and pipe or pipe insulation, using joint sealants appropriate for size, depth, and location of joint. Refer to Division 07 Section "Joint Sealants" for materials and installation.
- Q. Aboveground, Exterior-Wall Pipe Penetrations: Seal penetrations using sleeves and mechanical sleeve seals. Select sleeve size to allow for 1-inch annular clear space between pipe and sleeve for installing mechanical sleeve seals.
- 1. Install steel pipe for sleeves smaller than 6 inches in diameter.
 - 2. Install cast-iron "wall pipes" for sleeves 6 inches and larger in diameter.
 - 3. Mechanical Sleeve Seal Installation: Select type and number of sealing elements required for pipe material and size. Position pipe in center of sleeve. Assemble mechanical sleeve seals and install in annular space between pipe and sleeve. Tighten bolts against pressure plates that cause sealing elements to expand and make watertight seal.
- R. Underground, Exterior-Wall Pipe Penetrations: Install cast-iron "wall pipes" for sleeves. Seal pipe penetrations using mechanical sleeve seals. Select sleeve size to allow for 1-inch annular clear space between pipe and sleeve for installing mechanical sleeve seals.
- 1. Mechanical Sleeve Seal Installation: Select type and number of sealing elements required for pipe material and size. Position pipe in center of sleeve. Assemble mechanical sleeve seals and install in annular space between pipe and sleeve. Tighten bolts against pressure plates that cause sealing elements to expand and make watertight seal.
- S. Fire-Barrier Penetrations: Maintain indicated fire rating of walls, partitions, ceilings, and floors at pipe penetrations. Seal pipe penetrations with firestop materials. Refer to Division 07 Section "Penetration Firestopping" for materials.
- T. Verify final equipment locations for roughing-in.
- U. Refer to equipment specifications in other Sections of these Specifications for roughing-in requirements.

3.2 PIPING JOINT CONSTRUCTION

- A. Join pipe and fittings according to the following requirements and Division 22 Sections specifying piping systems.
- B. Ream ends of pipes and tubes and remove burrs. Bevel plain ends of steel pipe.
- C. Remove scale, slag, dirt, and debris from inside and outside of pipe and fittings before assembly.
- D. Soldered Joints: Apply ASTM B 813, water-flushable flux, unless otherwise indicated, to tube end. Construct joints according to ASTM B 828 or CDA's "Copper Tube Handbook," using lead-free solder alloy complying with ASTM B 32.
- E. Brazed Joints: Construct joints according to AWS's "Brazing Handbook," "Pipe and Tube" Chapter, using copper-phosphorus brazing filler metal complying with AWS A5.8.
- F. Threaded Joints: Thread pipe with tapered pipe threads according to ASME B1.20.1. Cut threads full and clean using sharp dies. Ream threaded pipe ends to remove burrs and restore full ID. Join pipe fittings and valves as follows:
 - 1. Apply appropriate tape or thread compound to external pipe threads unless dry seal threading is specified.
 - 2. Damaged Threads: Do not use pipe or pipe fittings with threads that are corroded or damaged. Do not use pipe sections that have cracked or open welds.
- G. Welded Joints: Construct joints according to AWS D10.12, using qualified processes and welding operators according to Part 1 "Quality Assurance" Article.
- H. Flanged Joints: Select appropriate gasket material, size, type, and thickness for service application. Install gasket concentrically positioned. Use suitable lubricants on bolt threads.

3.3 PIPING CONNECTIONS

- A. Make connections according to the following, unless otherwise indicated:
 - 1. Install unions, in piping NPS 2 and smaller, adjacent to each valve and at final connection to each piece of equipment.
 - 2. Install flanges, in piping NPS 2-1/2 and larger, adjacent to flanged valves and at final connection to each piece of equipment.
 - 3. Dry Piping Systems: Install dielectric unions and flanges to connect piping materials of dissimilar metals.
 - 4. Wet Piping Systems: Install dielectric coupling and nipple fittings to connect piping materials of dissimilar metals.

3.4 EQUIPMENT INSTALLATION - COMMON REQUIREMENTS

- A. Install equipment to allow maximum possible headroom unless specific mounting heights are not indicated.
- B. Install equipment level and plumb, parallel and perpendicular to other building systems and components in exposed interior spaces, unless otherwise indicated.
- C. Install plumbing equipment to facilitate service, maintenance, and repair or replacement of components. Connect equipment for ease of disconnecting, with minimum interference to other installations. Extend grease fittings to accessible locations.
- D. Install equipment to allow right of way for piping installed at required slope.

3.5 PAINTING

- A. Painting of plumbing systems, equipment, and components is specified in Division 09 Sections "Interior Painting" and "Exterior Painting."
- B. Damage and Touchup: Repair marred and damaged factory-painted finishes with materials and procedures to match original factory finish.

3.6 CONCRETE BASES

- A. Concrete Bases: Anchor equipment to concrete base according to equipment manufacturer's written instructions and according to seismic codes at Project.
 - 1. Construct concrete bases of dimensions indicated, but not less than 4 inches larger in both directions than supported unit.
 - 2. Install dowel rods to connect concrete base to concrete floor. Unless otherwise indicated, install dowel rods on 18-inch centers around the full perimeter of the base.
 - 3. Install epoxy-coated anchor bolts for supported equipment that extend through concrete base, and anchor into structural concrete floor.
 - 4. Place and secure anchorage devices. Use supported equipment manufacturer's setting drawings, templates, diagrams, instructions, and directions furnished with items to be embedded.
 - 5. Install anchor bolts to elevations required for proper attachment to supported equipment.
 - 6. Install anchor bolts according to anchor-bolt manufacturer's written instructions.
 - 7. Use 3000-psi, 28-day compressive-strength concrete and reinforcement as specified in Division 03 Section "Cast-in-Place Concrete."

3.7 ERECTION OF METAL SUPPORTS AND ANCHORAGES

- A. Refer to Division 05 Section "Metal Fabrications" for structural steel.
- B. Cut, fit, and place miscellaneous metal supports accurately in location, alignment, and elevation to support and anchor plumbing materials and equipment.
- C. Field Welding: Comply with AWS D1.1.

3.8 ERECTION OF WOOD SUPPORTS AND ANCHORAGES

- A. Cut, fit, and place wood grounds, nailers, blocking, and anchorages to support, and anchor plumbing materials and equipment.
- B. Select fastener sizes that will not penetrate members if opposite side will be exposed to view or will receive finish materials. Tighten connections between members. Install fasteners without splitting wood members.
- C. Attach to substrates as required to support applied loads.

3.9 GROUTING

- A. Mix and install grout for plumbing equipment base bearing surfaces, pump and other equipment base plates, and anchors.
- B. Clean surfaces that will come into contact with grout.
- C. Provide forms as required for placement of grout.

- D. Avoid air entrapment during placement of grout.
- E. Place grout, completely filling equipment bases.
- F. Place grout on concrete bases and provide smooth bearing surface for equipment.
- G. Place grout around anchors.
- H. Cure placed grout.

END OF SECTION 22 0500

SECTION 22 0529 - HANGERS AND SUPPORTS FOR PLUMBING PIPING AND EQUIPMENT

PART 1 - GENERAL

1.1 RELATED DOCUMENTS

- A. Drawings and general provisions of the Contract, including General and Supplementary Conditions and Division 01 Specification Sections, apply to this Section.

1.2 SUMMARY

- A. Section Includes:
 - 1. Metal pipe hangers and supports.
 - 2. Trapeze pipe hangers.
 - 3. Metal framing systems.
 - 4. Thermal-hanger shield inserts.
 - 5. Fastener systems.
 - 6. Pipe stands.
 - 7. Pipe positioning systems.
 - 8. Equipment supports.
- B. Related Sections:
 - 1. Division 05 Section "Metal Fabrications" for structural-steel shapes and plates for trapeze hangers for pipe and equipment supports.
 - 2. Division 21 fire-suppression piping Sections for pipe hangers for fire-suppression piping.

1.3 DEFINITIONS

- A. MSS: Manufacturers Standardization Society of The Valve and Fittings Industry Inc.

1.4 PERFORMANCE REQUIREMENTS

- A. Delegated Design: Design trapeze pipe hangers and equipment supports, including comprehensive engineering analysis by a qualified professional engineer, using performance requirements and design criteria indicated.
- B. Structural Performance: Hangers and supports for plumbing piping and equipment shall withstand the effects of gravity loads and stresses within limits and under conditions indicated according to ASCE/SEI 7.
 - 1. Design supports for multiple pipes, including pipe stands, capable of supporting combined weight of supported systems, system contents, and test water.
 - 2. Design equipment supports capable of supporting combined operating weight of supported equipment and connected systems and components.
 - 3. Design seismic-restraint hangers and supports for piping and equipment.

1.5 SUBMITTALS

- A. Product Data: For each type of product indicated.
- B. Shop Drawings: Show fabrication and installation details and include calculations for the following; include Product Data for components:

1. Trapeze pipe hangers.
 2. Metal framing systems.
 3. Pipe stands.
 4. Equipment supports.
- C. Delegated-Design Submittal: For trapeze hangers indicated to comply with performance requirements and design criteria, including analysis data signed and sealed by the qualified professional engineer responsible for their preparation.
1. Detail fabrication and assembly of trapeze hangers.
 2. Design Calculations: Calculate requirements for designing trapeze hangers.
- D. Welding certificates.

1.6 QUALITY ASSURANCE

- A. Structural Steel Welding Qualifications: Qualify procedures and personnel according to AWS D1.1/D1.1M, "Structural Welding Code - Steel."
- B. Pipe Welding Qualifications: Qualify procedures and operators according to ASME Boiler and Pressure Vessel Code.

PART 2 - PRODUCTS

2.1 METAL PIPE HANGERS AND SUPPORTS

- A. Carbon-Steel Pipe Hangers and Supports:
1. Description: MSS SP-58, Types 1 through 58, factory-fabricated components.
 2. Galvanized Metallic Coatings: Pregalvanized or hot dipped.
 3. Nonmetallic Coatings: Plastic coating, jacket, or liner.
 4. Padded Hangers: Hanger with fiberglass or other pipe insulation pad or cushion to support bearing surface of piping.
 5. Hanger Rods: Continuous-thread rod, nuts, and washer made of carbon steel.
- B. Stainless-Steel Pipe Hangers and Supports:
1. Description: MSS SP-58, Types 1 through 58, factory-fabricated components.
 2. Padded Hangers: Hanger with fiberglass or other pipe insulation pad or cushion to support bearing surface of piping.
 3. Hanger Rods: Continuous-thread rod, nuts, and washer made of stainless steel.

2.2 TRAPEZE PIPE HANGERS

- A. Description: MSS SP-69, Type 59, shop- or field-fabricated pipe-support assembly made from structural carbon-steel shapes with MSS SP-58 carbon-steel hanger rods, nuts, saddles, and U-bolts.

2.3 METAL FRAMING SYSTEMS

- A. MFMA Manufacturer Metal Framing Systems:
1. Manufacturers: Subject to compliance with requirements, provide products by one of the following:
 - a. Allied Tube & Conduit.
 - b. Cooper B-Line, Inc.
 - c. Flex-Strut Inc.

- d. GS Metals Corp.
- e. Thomas & Betts Corporation.
- f. Unistrut Corporation; Tyco International, Ltd.
- g. Wesanco, Inc.
2. Description: Shop- or field-fabricated pipe-support assembly for supporting multiple parallel pipes.
3. Standard: MFMA-4.
4. Channels: Continuous slotted steel channel with inturned lips.
5. Channel Nuts: Formed or stamped steel nuts or other devices designed to fit into channel slot and, when tightened, prevent slipping along channel.
6. Hanger Rods: Continuous-thread rod, nuts, and washer made of carbon steel.
7. Metallic Coating: Electroplated zinc.
8. Paint Coating: Epoxy.
9. Plastic Coating: Polyester.

2.4 THERMAL-HANGER SHIELD INSERTS

- A. Manufacturers: Subject to compliance with requirements, provide products by one of the following:
 1. Carpenter & Paterson, Inc.
 2. Clement Support Services.
 3. ERICO International Corporation.
 4. National Pipe Hanger Corporation.
 5. PHS Industries, Inc.
 6. Pipe Shields, Inc.; a subsidiary of Piping Technology & Products, Inc.
 7. Piping Technology & Products, Inc.
 8. Rilco Manufacturing Co., Inc.
 9. Value Engineered Products, Inc.
- B. Insulation-Insert Material for Cold Piping: ASTM C 552, Type II cellular glass with 100-psig or ASTM C 591, Type VI, Grade 1 polyisocyanurate with 125-psig minimum compressive strength and vapor barrier.
- C. Insulation-Insert Material for Hot Piping: Water-repellent treated, ASTM C 533, Type I calcium silicate with 100-psig or ASTM C 552, Type II cellular glass with 100-psig or ASTM C 591, Type VI, Grade 1 polyisocyanurate with 125-psig minimum compressive strength.
- D. For Trapeze or Clamped Systems: Insert and shield shall cover entire circumference of pipe.
- E. For Clevis or Band Hangers: Insert and shield shall cover lower 180 degrees of pipe.
- F. Insert Length: Extend 2 inches beyond sheet metal shield for piping operating below ambient air temperature.

2.5 FASTENER SYSTEMS

- A. Powder-Actuated Fasteners: Threaded-steel stud, for use in hardened portland cement concrete with pull-out, tension, and shear capacities appropriate for supported loads and building materials where used.
- B. Mechanical-Expansion Anchors: Insert-wedge-type, stainless- steel anchors, for use in hardened portland cement concrete; with pull-out, tension, and shear capacities appropriate for supported loads and building materials where used.

2.6 PIPE STANDS

- A. General Requirements for Pipe Stands: Shop- or field-fabricated assemblies made of manufactured corrosion-resistant components to support roof-mounted piping.
- B. Compact Pipe Stand: One-piece plastic unit with integral-rod roller, pipe clamps, or V-shaped cradle to support pipe, for roof installation without membrane penetration.
- C. Low-Type, Single-Pipe Stand: One-piece stainless-steel base unit with plastic roller, for roof installation without membrane penetration.
- D. High-Type, Single-Pipe Stand:
 - 1. Description: Assembly of base, vertical and horizontal members, and pipe support, for roof installation without membrane penetration.
 - 2. Base: Stainless steel.
 - 3. Vertical Members: Two or more cadmium-plated-steel or stainless-steel, continuous-thread rods.
 - 4. Horizontal Member: Cadmium-plated-steel or stainless-steel rod with plastic or stainless-steel, roller-type pipe support.
- E. High-Type, Multiple-Pipe Stand:
 - 1. Description: Assembly of bases, vertical and horizontal members, and pipe supports, for roof installation without membrane penetration.
 - 2. Bases: One or more; plastic.
 - 3. Vertical Members: Two or more protective-coated-steel channels.
 - 4. Horizontal Member: Protective-coated-steel channel.
 - 5. Pipe Supports: Galvanized-steel, clevis-type pipe hangers.
- F. Curb-Mounting-Type Pipe Stands: Shop- or field-fabricated pipe supports made from structural-steel shapes, continuous-thread rods, and rollers, for mounting on permanent stationary roof curb.

2.7 PIPE POSITIONING SYSTEMS

- A. Description: IAPMO PS 42, positioning system of metal brackets, clips, and straps for positioning piping in pipe spaces; for plumbing fixtures in commercial applications.

2.8 EQUIPMENT SUPPORTS

- A. Description: Welded, shop- or field-fabricated equipment support made from structural carbon-steel shapes.

2.9 MISCELLANEOUS MATERIALS

- A. Structural Steel: ASTM A 36/A 36M, carbon-steel plates, shapes, and bars; black and galvanized.
- B. Grout: ASTM C 1107, factory-mixed and -packaged, dry, hydraulic-cement, nonshrink and nonmetallic grout; suitable for interior and exterior applications.
 - 1. Properties: Nonstaining, noncorrosive, and nongaseous.
 - 2. Design Mix: 5000-psi, 28-day compressive strength.

PART 3 - EXECUTION

3.1 HANGER AND SUPPORT INSTALLATION

- A. Metal Pipe-Hanger Installation: Comply with MSS SP-69 and MSS SP-89. Install hangers, supports, clamps, and attachments as required to properly support piping from the building structure.
- B. Metal Trapeze Pipe-Hanger Installation: Comply with MSS SP-69 and MSS SP-89. Arrange for grouping of parallel runs of horizontal piping, and support together on field-fabricated trapeze pipe hangers.
 - 1. Pipes of Various Sizes: Support together and space trapezes for smallest pipe size or install intermediate supports for smaller diameter pipes as specified for individual pipe hangers.
 - 2. Field fabricate from ASTM A 36/A 36M, carbon-steel shapes selected for loads being supported. Weld steel according to AWS D1.1/D1.1M.
- C. Fiberglass Pipe-Hanger Installation: Comply with applicable portions of MSS SP-69 and MSS SP-89. Install hangers and attachments as required to properly support piping from building structure.
- D. Metal Framing System Installation: Arrange for grouping of parallel runs of piping, and support together on field-assembled metal framing systems.
- E. Fiberglass Strut System Installation: Arrange for grouping of parallel runs of piping, and support together on field-assembled fiberglass struts.
- F. Thermal-Hanger Shield Installation: Install in pipe hanger or shield for insulated piping.
- G. Fastener System Installation:
 - 1. Install powder-actuated fasteners for use in lightweight concrete or concrete slabs less than 4 inches thick in concrete after concrete is placed and completely cured. Use operators that are licensed by powder-actuated tool manufacturer. Install fasteners according to powder-actuated tool manufacturer's operating manual.
 - 2. Install mechanical-expansion anchors in concrete after concrete is placed and completely cured. Install fasteners according to manufacturer's written instructions.
- H. Pipe Stand Installation:
 - 1. Pipe Stand Types except Curb-Mounted Type: Assemble components and mount on smooth roof surface. Do not penetrate roof membrane.
 - 2. Curb-Mounted-Type Pipe Stands: Assemble components or fabricate pipe stand and mount on permanent, stationary roof curb. See Division 07 Section "Roof Accessories" for curbs.
- I. Pipe Positioning-System Installation: Install support devices to make rigid supply and waste piping connections to each plumbing fixture. See Division 22 plumbing fixture Sections for requirements for pipe positioning systems for plumbing fixtures.
- J. Install hangers and supports complete with necessary attachments, inserts, bolts, rods, nuts, washers, and other accessories.
- K. Equipment Support Installation: Fabricate from welded-structural-steel shapes.
- L. Install hangers and supports to allow controlled thermal and seismic movement of piping systems, to permit freedom of movement between pipe anchors, and to facilitate action of expansion joints, expansion loops, expansion bends, and similar units.
- M. Install lateral bracing with pipe hangers and supports to prevent swaying.
- N. Install building attachments within concrete slabs or attach to structural steel. Install additional attachments at concentrated loads, including valves, flanges, and strainers, NPS 2 and larger and at

changes in direction of piping. Install concrete inserts before concrete is placed; fasten inserts to forms and install reinforcing bars through openings at top of inserts.

- O. Load Distribution: Install hangers and supports so that piping live and dead loads and stresses from movement will not be transmitted to connected equipment.
- P. Pipe Slopes: Install hangers and supports to provide indicated pipe slopes and to not exceed maximum pipe deflections allowed by ASME B31.9 for building services piping.
- Q. Insulated Piping:
 - 1. Attach clamps and spacers to piping.
 - a. Piping Operating above Ambient Air Temperature: Clamp may project through insulation.
 - b. Piping Operating below Ambient Air Temperature: Use thermal-hanger shield insert with clamp sized to match OD of insert.
 - c. Do not exceed pipe stress limits allowed by ASME B31.9 for building services piping.
 - 2. Install MSS SP-58, Type 39, protection saddles if insulation without vapor barrier is indicated. Fill interior voids with insulation that matches adjoining insulation.
 - a. Option: Thermal-hanger shield inserts may be used. Include steel weight-distribution plate for pipe NPS 4 and larger if pipe is installed on rollers.
 - 3. Install MSS SP-58, Type 40, protective shields on cold piping with vapor barrier. Shields shall span an arc of 180 degrees.
 - a. Option: Thermal-hanger shield inserts may be used. Include steel weight-distribution plate for pipe NPS 4 and larger if pipe is installed on rollers.
 - 4. Shield Dimensions for Pipe: Not less than the following:
 - a. NPS 1/4 to NPS 3-1/2: 12 inches long and 0.048 inch thick.
 - b. NPS 4: 12 inches long and 0.06 inch thick.
 - c. NPS 5 and NPS 6: 18 inches long and 0.06 inch thick.
 - d. NPS 8 to NPS 14: 24 inches long and 0.075 inch thick.
 - e. NPS 16 to NPS 24: 24 inches long and 0.105 inch thick.
 - 5. Pipes NPS 8 and Larger: Include wood or reinforced calcium-silicate-insulation inserts of length at least as long as protective shield.
 - 6. Thermal-Hanger Shields: Install with insulation same thickness as piping insulation.

3.2 EQUIPMENT SUPPORTS

- A. Fabricate structural-steel stands to suspend equipment from structure overhead or to support equipment above floor.
- B. Grouting: Place grout under supports for equipment and make bearing surface smooth.
- C. Provide lateral bracing, to prevent swaying, for equipment supports.

3.3 METAL FABRICATIONS

- A. Cut, drill, and fit miscellaneous metal fabrications for trapeze pipe hangers and equipment supports.
- B. Fit exposed connections together to form hairline joints. Field weld connections that cannot be shop welded because of shipping size limitations.
- C. Field Welding: Comply with AWS D1.1/D1.1M procedures for shielded, metal arc welding; appearance and quality of welds; and methods used in correcting welding work; and with the following:
 - 1. Use materials and methods that minimize distortion and develop strength and corrosion resistance of base metals.
 - 2. Obtain fusion without undercut or overlap.
 - 3. Remove welding flux immediately.

4. Finish welds at exposed connections so no roughness shows after finishing and so contours of welded surfaces match adjacent contours.

3.4 ADJUSTING

- A. Hanger Adjustments: Adjust hangers to distribute loads equally on attachments and to achieve indicated slope of pipe.
- B. Trim excess length of continuous-thread hanger and support rods to 1-1/2 inches.

3.5 PAINTING

- A. Touchup: Clean field welds and abraded areas of shop paint. Paint exposed areas immediately after erecting hangers and supports. Use same materials as used for shop painting. Comply with SSPC-PA 1 requirements for touching up field-painted surfaces.
 1. Apply paint by brush or spray to provide a minimum dry film thickness of 2.0 mils.
- B. Touchup: Cleaning and touchup painting of field welds, bolted connections, and abraded areas of shop paint on miscellaneous metal are specified in Division 09 painting Sections.
- C. Galvanized Surfaces: Clean welds, bolted connections, and abraded areas and apply galvanizing-repair paint to comply with ASTM A 780.

3.6 HANGER AND SUPPORT SCHEDULE

- A. Specific hanger and support requirements are in Sections specifying piping systems and equipment.
- B. Comply with MSS SP-69 for pipe-hanger selections and applications that are not specified in piping system Sections.
- C. Use hangers and supports with galvanized metallic coatings for piping and equipment that will not have field-applied finish.
- D. Use nonmetallic coatings on attachments for electrolytic protection where attachments are in direct contact with copper tubing.
- E. Use carbon-steel pipe hangers and supports, metal trapeze pipe hangers and metal framing systems and attachments for general service applications.
- F. Use copper-plated pipe hangers and copper or stainless-steel attachments for copper piping and tubing.
- G. Use padded hangers for piping that is subject to scratching.
- H. Use thermal-hanger shield inserts for insulated piping and tubing.
- I. Horizontal-Piping Hangers and Supports: Unless otherwise indicated and except as specified in piping system Sections, install the following types:
 1. Adjustable, Steel Clevis Hangers (MSS Type 1): For suspension of noninsulated or insulated, stationary pipes NPS 1/2 to NPS 30.
 2. Yoke-Type Pipe Clamps (MSS Type 2): For suspension of up to 1050 deg F, pipes NPS 4 to NPS 24, requiring up to 4 inches of insulation.
 3. Carbon- or Alloy-Steel, Double-Bolt Pipe Clamps (MSS Type 3): For suspension of pipes NPS 3/4 to NPS 36, requiring clamp flexibility and up to 4 inches of insulation.

4. Steel Pipe Clamps (MSS Type 4): For suspension of cold and hot pipes NPS 1/2 to NPS 24 if little or no insulation is required.
 5. Pipe Hangers (MSS Type 5): For suspension of pipes NPS 1/2 to NPS 4, to allow off-center closure for hanger installation before pipe erection.
 6. Adjustable, Swivel Split- or Solid-Ring Hangers (MSS Type 6): For suspension of noninsulated, stationary pipes NPS 3/4 to NPS 8.
 7. Adjustable, Steel Band Hangers (MSS Type 7): For suspension of noninsulated, stationary pipes NPS 1/2 to NPS 8.
 8. Adjustable Band Hangers (MSS Type 9): For suspension of noninsulated, stationary pipes NPS 1/2 to NPS 8.
 9. Adjustable, Swivel-Ring Band Hangers (MSS Type 10): For suspension of noninsulated, stationary pipes NPS 1/2 to NPS 8.
 10. Split Pipe Ring with or without Turnbuckle Hangers (MSS Type 11): For suspension of noninsulated, stationary pipes NPS 3/8 to NPS 8.
 11. Extension Hinged or Two-Bolt Split Pipe Clamps (MSS Type 12): For suspension of noninsulated, stationary pipes NPS 3/8 to NPS 3.
 12. U-Bolts (MSS Type 24): For support of heavy pipes NPS 1/2 to NPS 30.
 13. Clips (MSS Type 26): For support of insulated pipes not subject to expansion or contraction.
 14. Pipe Saddle Supports (MSS Type 36): For support of pipes NPS 4 to NPS 36, with steel-pipe base stanchion support and cast-iron floor flange or carbon-steel plate.
 15. Pipe Stanchion Saddles (MSS Type 37): For support of pipes NPS 4 to NPS 36, with steel-pipe base stanchion support and cast-iron floor flange or carbon-steel plate, and with U-bolt to retain pipe.
 16. Adjustable Pipe Saddle Supports (MSS Type 38): For stanchion-type support for pipes NPS 2-1/2 to NPS 36 if vertical adjustment is required, with steel-pipe base stanchion support and cast-iron floor flange.
 17. Single-Pipe Rolls (MSS Type 41): For suspension of pipes NPS 1 to NPS 30, from two rods if longitudinal movement caused by expansion and contraction might occur.
 18. Adjustable Roller Hangers (MSS Type 43): For suspension of pipes NPS 2-1/2 to NPS 24, from single rod if horizontal movement caused by expansion and contraction might occur.
 19. Complete Pipe Rolls (MSS Type 44): For support of pipes NPS 2 to NPS 42 if longitudinal movement caused by expansion and contraction might occur but vertical adjustment is not necessary.
 20. Pipe Roll and Plate Units (MSS Type 45): For support of pipes NPS 2 to NPS 24 if small horizontal movement caused by expansion and contraction might occur and vertical adjustment is not necessary.
 21. Adjustable Pipe Roll and Base Units (MSS Type 46): For support of pipes NPS 2 to NPS 30 if vertical and lateral adjustment during installation might be required in addition to expansion and contraction.
- J. Vertical-Piping Clamps: Unless otherwise indicated and except as specified in piping system Sections, install the following types:
1. Extension Pipe or Riser Clamps (MSS Type 8): For support of pipe risers NPS 3/4 to NPS 24.
 2. Carbon- or Alloy-Steel Riser Clamps (MSS Type 42): For support of pipe risers NPS 3/4 to NPS 24 if longer ends are required for riser clamps.
- K. Hanger-Rod Attachments: Unless otherwise indicated and except as specified in piping system Sections, install the following types:
1. Steel Turnbuckles (MSS Type 13): For adjustment up to 6 inches for heavy loads.
 2. Steel Clevises (MSS Type 14): For 120 to 450 deg F piping installations.
 3. Swivel Turnbuckles (MSS Type 15): For use with MSS Type 11, split pipe rings.
 4. Malleable-Iron Sockets (MSS Type 16): For attaching hanger rods to various types of building attachments.
 5. Steel Weldless Eye Nuts (MSS Type 17): For 120 to 450 deg F piping installations.
- L. Building Attachments: Unless otherwise indicated and except as specified in piping system Sections, install the following types:
1. Steel or Malleable Concrete Inserts (MSS Type 18): For upper attachment to suspend pipe hangers from concrete ceiling.

2. Top-Beam C-Clamps (MSS Type 19): For use under roof installations with bar-joist construction, to attach to top flange of structural shape.
 3. Side-Beam or Channel Clamps (MSS Type 20): For attaching to bottom flange of beams, channels, or angles.
 4. Center-Beam Clamps (MSS Type 21): For attaching to center of bottom flange of beams.
 5. Welded Beam Attachments (MSS Type 22): For attaching to bottom of beams if loads are considerable and rod sizes are large.
 6. C-Clamps (MSS Type 23): For structural shapes.
 7. Top-Beam Clamps (MSS Type 25): For top of beams if hanger rod is required tangent to flange edge.
 8. Side-Beam Clamps (MSS Type 27): For bottom of steel I-beams.
 9. Steel-Beam Clamps with Eye Nuts (MSS Type 28): For attaching to bottom of steel I-beams for heavy loads.
 10. Linked-Steel Clamps with Eye Nuts (MSS Type 29): For attaching to bottom of steel I-beams for heavy loads, with link extensions.
 11. Malleable-Beam Clamps with Extension Pieces (MSS Type 30): For attaching to structural steel.
 12. Welded-Steel Brackets: For support of pipes from below or for suspending from above by using clip and rod. Use one of the following for indicated loads:
 - a. Light (MSS Type 31): 750 lb.
 - b. Medium (MSS Type 32): 1500 lb.
 - c. Heavy (MSS Type 33): 3000 lb.
 13. Side-Beam Brackets (MSS Type 34): For sides of steel or wooden beams.
 14. Plate Lugs (MSS Type 57): For attaching to steel beams if flexibility at beam is required.
 15. Horizontal Travelers (MSS Type 58): For supporting piping systems subject to linear horizontal movement where headroom is limited.
- M. Saddles and Shields: Unless otherwise indicated and except as specified in piping system Sections, install the following types:
1. Steel-Pipe-Covering Protection Saddles (MSS Type 39): To fill interior voids with insulation that matches adjoining insulation.
 2. Protection Shields (MSS Type 40): Of length recommended in writing by manufacturer to prevent crushing insulation.
 3. Thermal-Hanger Shield Inserts: For supporting insulated pipe.
- N. Spring Hangers and Supports: Unless otherwise indicated and except as specified in piping system Sections, install the following types:
1. Restraint-Control Devices (MSS Type 47): Where indicated to control piping movement.
 2. Spring Cushions (MSS Type 48): For light loads if vertical movement does not exceed 1-1/4 inches.
 3. Spring-Cushion Roll Hangers (MSS Type 49): For equipping Type 41, roll hanger with springs.
 4. Spring Sway Braces (MSS Type 50): To retard sway, shock, vibration, or thermal expansion in piping systems.
 5. Variable-Spring Hangers (MSS Type 51): Preset to indicated load and limit variability factor to 25 percent to allow expansion and contraction of piping system from hanger.
 6. Variable-Spring Base Supports (MSS Type 52): Preset to indicated load and limit variability factor to 25 percent to allow expansion and contraction of piping system from base support.
 7. Variable-Spring Trapeze Hangers (MSS Type 53): Preset to indicated load and limit variability factor to 25 percent to allow expansion and contraction of piping system from trapeze support.
 8. Constant Supports: For critical piping stress and if necessary to avoid transfer of stress from one support to another support, critical terminal, or connected equipment. Include auxiliary stops for erection, hydrostatic test, and load-adjustment capability. These supports include the following types:
 - a. Horizontal (MSS Type 54): Mounted horizontally.
 - b. Vertical (MSS Type 55): Mounted vertically.
 - c. Trapeze (MSS Type 56): Two vertical-type supports and one trapeze member.
- O. Comply with MSS SP-69 for trapeze pipe-hanger selections and applications that are not specified in piping system Sections.

- P. Comply with MFMA-103 for metal framing system selections and applications that are not specified in piping system Sections.
- Q. Use powder-actuated fasteners or mechanical-expansion anchors instead of building attachments where required in concrete construction.
- R. Use pipe positioning systems in pipe spaces behind plumbing fixtures to support supply and waste piping for plumbing fixtures.

END OF SECTION 22 0529

SECTION 220553 - IDENTIFICATION FOR PLUMBING PIPING AND EQUIPMENT

PART 1 - GENERAL

1.1 SUMMARY

- A. Section Includes:
 - 1. Equipment labels.
 - 2. Warning signs and labels.
 - 3. Pipe labels.

1.2 SUBMITTAL

- A. Product Data: For each type of product indicated.

PART 2 - PRODUCTS

2.1 EQUIPMENT LABELS

- A. Plastic Labels for Equipment:
 - 1. Material and Thickness: Multilayer, multicolor, plastic labels for mechanical engraving, 1/8 inch (3.2 mm) thick, and having predrilled holes for attachment hardware.
 - 2. Letter Color: White.
 - 3. Background Color: Black.
 - 4. Maximum Temperature: Able to withstand temperatures up to 160 deg F (71 deg C).
 - 5. Minimum Label Size: Length and width vary for required label content, but not less than 2-1/2 by 3/4 inch (64 by 19 mm).
 - 6. Minimum Letter Size: 1/4 inch (6.4 mm) for name of units if viewing distance is less than 24 inches (600 mm), 1/2 inch (13 mm) for viewing distances up to 72 inches (1830 mm), and proportionately larger lettering for greater viewing distances. Include secondary lettering two-thirds to three-fourths the size of principal lettering.
 - 7. Fasteners: Stainless-steel rivets or self-tapping screws.
 - 8. Adhesive: Contact-type permanent adhesive, compatible with label and with substrate.
- B. Label Content: Include equipment's Drawing designation or unique equipment number, Drawing numbers where equipment is indicated (plans, details, and schedules), plus the Specification Section number and title where equipment is specified.
- C. Equipment Label Schedule: For each item of equipment to be labeled, on 8-1/2-by-11-inch (A4) bond paper. Tabulate equipment identification number and identify Drawing numbers where equipment is indicated (plans, details, and schedules), plus the Specification Section number and title where equipment is specified. Equipment schedule shall be included in operation and maintenance data.

2.2 PIPE LABELS

- A. General Requirements for Manufactured Pipe Labels: Preprinted, color-coded, with lettering indicating service, and showing flow direction.
- B. Pretensioned Pipe Labels: Precoiled, semirigid plastic formed to cover full circumference of pipe and to attach to pipe without fasteners or adhesive.

- C. Pipe Label Contents: Include identification of piping service using same designations or abbreviations as used on Drawings, pipe size, and an arrow indicating flow direction.
 - 1. Flow-Direction Arrows: Integral with piping system service lettering to accommodate both directions, or as separate unit on each pipe label to indicate flow direction.
 - 2. Lettering Size: At least 1-1/2 inches (38 mm) high.

PART 3 - EXECUTION

3.1 PREPARATION

- A. Clean piping and equipment surfaces of substances that could impair bond of identification devices, including dirt, oil, grease, release agents, and incompatible primers, paints, and encapsulants.

3.2 EQUIPMENT LABEL INSTALLATION

- A. Install or permanently fasten labels on each major item of mechanical equipment.
- B. Locate equipment labels where accessible and visible.

3.3 PIPE LABEL INSTALLATION

- A. Locate pipe labels where piping is exposed or above accessible ceilings in finished spaces; machine rooms; accessible maintenance spaces such as shafts, tunnels, and plenums; and exterior exposed locations as follows:
 - 1. Near each valve and control device.
 - 2. Near each branch connection, excluding short takeoffs for fixtures and terminal units. Where flow pattern is not obvious, mark each pipe at branch.
 - 3. Near penetrations through walls, floors, ceilings, and inaccessible enclosures.
 - 4. At access doors, manholes, and similar access points that permit view of concealed piping.
 - 5. Near major equipment items and other points of origination and termination.
 - 6. Spaced at maximum intervals of 50 feet (15 m) along each run. Reduce intervals to 25 feet (7.6 m) in areas of congested piping and equipment.
 - 7. On piping above removable acoustical ceilings. Omit intermediately spaced labels.
- B. Pipe Label Color Schedule:
 - 1. Domestic Cold Water Piping:
 - a. Background Color: Green
 - b. Letter Color: Black.
 - 2. Domestic Hot Water Piping:
 - a. Background Color: Yellow
 - b. Letter Color: Black.
 - 3. Roof Drain Piping:
 - a. Background Color: Green.
 - b. Letter Color: Black.

END OF SECTION 220553

SECTION 22 0700 - PLUMBING INSULATION

PART 1 - GENERAL

1.1 RELATED DOCUMENTS

- A. Drawings and general provisions of the Contract, including General and Supplementary Conditions and Division 01 Specification Sections, apply to this Section.

1.2 SUMMARY

- A. Section Includes:
 - 1. Insulation Materials:
 - a. Mineral fiber.
 - 2. Insulating cements.
 - 3. Adhesives.
 - 4. Mastics.
 - 5. Lagging adhesives.
 - 6. Sealants.
 - 7. Factory-applied jackets.
 - 8. Field-applied fabric-reinforcing mesh.
 - 9. Field-applied cloths.
 - 10. Field-applied jackets.
 - 11. Tapes.
 - 12. Securements.
 - 13. Corner angles.
- B. Related Sections include the following:
 - 1. Division 23 Section "HVAC Insulation."

1.3 SUBMITTALS

- A. Product Data: For each type of product indicated. Include thermal conductivity, thickness, and jackets (both factory and field applied, if any).
- B. Shop Drawings:
 - 1. Detail application of protective shields, saddles, and inserts at hangers for each type of insulation and hanger.
 - 2. Detail attachment and covering of heat tracing inside insulation.
 - 3. Detail insulation application at pipe expansion joints for each type of insulation.
 - 4. Detail insulation application at elbows, fittings, flanges, valves, and specialties for each type of insulation.
 - 5. Detail removable insulation at piping specialties, equipment connections, and access panels.
 - 6. Detail application of field-applied jackets.
 - 7. Detail application at linkages of control devices.
 - 8. Detail field application for each equipment type.
- C. Qualification Data: For qualified Installer.
- D. Material Test Reports: From a qualified testing agency acceptable to authorities having jurisdiction indicating, interpreting, and certifying test results for compliance of insulation materials, sealers, attachments, cements, and jackets, with requirements indicated. Include dates of tests and test methods employed.
- E. Field quality-control reports.

1.4 QUALITY ASSURANCE

- A. Installer Qualifications: Skilled mechanics who have successfully completed an apprenticeship program or another craft training program certified by the Department of Labor, Bureau of Apprenticeship and Training.
- B. Fire-Test-Response Characteristics: Insulation and related materials shall have fire-test-response characteristics indicated, as determined by testing identical products per ASTM E 84, by a testing and inspecting agency acceptable to authorities having jurisdiction. Factory label insulation and jacket materials and adhesive, mastic, tapes, and cement material containers, with appropriate markings of applicable testing and inspecting agency.
 - 1. Insulation Installed Indoors: Flame-spread index of 25 or less, and smoke-developed index of 50 or less.
 - 2. Insulation Installed Outdoors: Flame-spread index of 75 or less, and smoke-developed index of 150 or less.

1.5 DELIVERY, STORAGE, AND HANDLING

- A. Packaging: Insulation material containers shall be marked by manufacturer with appropriate ASTM standard designation, type and grade, and maximum use temperature.

1.6 COORDINATION

- A. Coordinate size and location of supports, hangers, and insulation shields specified in Division 22 Section "Hangers and Supports for Plumbing Piping and Equipment."
- B. Coordinate clearance requirements with piping Installer for piping insulation application and equipment Installer for equipment insulation application. Before preparing piping Shop Drawings, establish and maintain clearance requirements for installation of insulation and field-applied jackets and finishes and for space required for maintenance.
- C. Coordinate installation and testing of heat tracing.

1.7 SCHEDULING

- A. Schedule insulation application after pressure testing systems and, where required, after installing and testing heat tracing. Insulation application may begin on segments that have satisfactory test results.
- B. Complete installation and concealment of plastic materials as rapidly as possible in each area of construction.

PART 2 - PRODUCTS

2.1 INDOOR PIPING INSULATION SCHEDULE

- A. Domestic Cold Water:
 - 1. Insulation shall be the following:
 - a. Mineral-Fiber, Preformed Pipe Insulation, Type I: 1/2 inch thick.
- B. Domestic Hot and Recirculated Hot Water:
 - 1. Insulation shall be the following:
 - a. Mineral-Fiber, Preformed Pipe Insulation, Type I: 1 inch thick.

- C. Condensate Drain Waste Piping :
 - 1. Insulation shall be the following:
 - a. Mineral-Fiber, Preformed Pipe Insulation, Type I: 1 inch thick.

2.2 INSULATION MATERIALS

- A. Comply with requirements in Part 3 schedule articles for where insulating materials shall be applied.
- B. Products shall not contain asbestos, lead, mercury, or mercury compounds.
- C. Products that come in contact with stainless steel shall have a leachable chloride content of less than 50 ppm when tested according to ASTM C 871.
- D. Insulation materials for use on austenitic stainless steel shall be qualified as acceptable according to ASTM C 795.
- E. Foam insulation materials shall not use CFC or HCFC blowing agents in the manufacturing process.
- F. Mineral-Fiber, Preformed Pipe Insulation:
 - 1. Products: Subject to compliance with requirements, provide one of the following:
 - a. Fibrex Insulations Inc.; Coreplus 1200.
 - b. Johns Manville; Micro-Lok.
 - c. Knauf Insulation; 1000(Pipe Insulation.
 - d. Manson Insulation Inc.; Alley-K.
 - e. Owens Corning; Fiberglas Pipe Insulation.
 - 2. Type I, 850 deg F Materials: Mineral or glass fibers bonded with a thermosetting resin. Comply with ASTM C 547, Type I, Grade A, with factory-applied ASJ-SSL. Factory-applied jacket requirements are specified in "Factory-Applied Jackets" Article.

2.3 INSULATING CEMENTS

- A. Mineral-Fiber Insulating Cement: Comply with ASTM C 195.
 - 1. Products: Subject to compliance with requirements, provide one of the following:
 - a. Insulco, Division of MFS, Inc.; Triple I.
 - b. P. K. Insulation Mfg. Co., Inc.; Super-Stik.

2.4 ADHESIVES

- A. Materials shall be compatible with insulation materials, jackets, and substrates and for bonding insulation to itself and to surfaces to be insulated, unless otherwise indicated.
- B. Mineral-Fiber Adhesive: Comply with MIL-A-3316C, Class 2, Grade A.
 - 1. Products: Subject to compliance with requirements, provide one of the following:
 - a. Childers Products, Division of ITW; CP-82.
 - b. Foster Products Corporation, H. B. Fuller Company; 85-20.
 - c. ITW TACC, Division of Illinois Tool Works; S-90/80.
 - d. Marathon Industries, Inc.; 225.
 - e. Mon-Eco Industries, Inc.; 22-25.
 - 2. For indoor applications, use adhesive that has a VOC content of 80 g/L or less when calculated according to 40 CFR 59, Subpart D (EPA Method 24).
- C. ASJ Adhesive, and FSK and PVDC Jacket Adhesive: Comply with MIL-A-3316C, Class 2, Grade A for bonding insulation jacket lap seams and joints.
 - 1. Products: Subject to compliance with requirements, provide one of the following:
 - a. Childers Products, Division of ITW; CP-82.
 - b. Foster Products Corporation, H. B. Fuller Company; 85-20.

- c. ITW TACC, Division of Illinois Tool Works; S-90/80.
 - d. Marathon Industries, Inc.; 225.
 - e. Mon-Eco Industries, Inc.; 22-25.
 2. For indoor applications, use adhesive that has a VOC content of 50 g/L or less when calculated according to 40 CFR 59, Subpart D (EPA Method 24).
- D. PVC Jacket Adhesive: Compatible with PVC jacket.
1. Products: Subject to compliance with requirements, provide one of the following:
 - a. Dow Chemical Company (The); 739, Dow Silicone.
 - b. Johns-Manville; Zeston Perma-Weld, CEEL-TITE Solvent Welding Adhesive.
 - c. P.I.C. Plastics, Inc.; Welding Adhesive.
 - d. Speedline Corporation; Speedline Vinyl Adhesive.
 2. For indoor applications, use adhesive that has a VOC content of 50 g/L or less when calculated according to 40 CFR 59, Subpart D (EPA Method 24).

2.5 MASTICS

- A. Materials shall be compatible with insulation materials, jackets, and substrates; comply with MIL-C-19565C, Type II.
1. For indoor applications, use mastics that have a VOC content of <Insert value> g/L or less when calculated according to 40 CFR 59, Subpart D (EPA Method 24).
- B. Vapor-Barrier Mastic: Water based; suitable for indoor and outdoor use on below ambient services.
1. Products: Subject to compliance with requirements, provide one of the following:
 - a. Childers Products, Division of ITW; CP-35.
 - b. Foster Products Corporation, H. B. Fuller Company; 30-90.
 - c. ITW TACC, Division of Illinois Tool Works; CB-50.
 - d. Marathon Industries, Inc.; 590.
 - e. Mon-Eco Industries, Inc.; 55-40.
 - f. Vimasco Corporation; 749.
 2. Water-Vapor Permeance: ASTM E 96, Procedure B, 0.013 perm at 43-mil dry film thickness.
 3. Service Temperature Range: Minus 20 to plus 180 deg F.
 4. Solids Content: ASTM D 1644, 59 percent by volume and 71 percent by weight.
 5. Color: White.
- C. Vapor-Barrier Mastic: Solvent based; suitable for indoor use on below ambient services.
1. Products: Subject to compliance with requirements, provide one of the following:
 - a. Childers Products, Division of ITW; CP-30.
 - b. Foster Products Corporation, H. B. Fuller Company; 30-35.
 - c. ITW TACC, Division of Illinois Tool Works; CB-25.
 - d. Marathon Industries, Inc.; 501.
 - e. Mon-Eco Industries, Inc.; 55-10.
 2. Water-Vapor Permeance: ASTM F 1249, 0.05 perm at 35-mil dry film thickness.
 3. Service Temperature Range: 0 to 180 deg F.
 4. Solids Content: ASTM D 1644, 44 percent by volume and 62 percent by weight.
 5. Color: White.
- D. Breather Mastic: Water based; suitable for indoor and outdoor use on above ambient services.
1. Products: Subject to compliance with requirements, provide one of the following:
 - a. Childers Products, Division of ITW; CP-10.
 - b. Foster Products Corporation, H. B. Fuller Company; 35-00.
 - c. ITW TACC, Division of Illinois Tool Works; CB-05/15.
 - d. Marathon Industries, Inc.; 550.
 - e. Mon-Eco Industries, Inc.; 55-50.
 - f. Vimasco Corporation; WC-1/WC-5.
 2. Water-Vapor Permeance: ASTM F 1249, 3 perms at 0.0625-inch dry film thickness.
 3. Service Temperature Range: Minus 20 to plus 200 deg F.
 4. Solids Content: 63 percent by volume and 73 percent by weight.
 5. Color: White.

2.6 SEALANTS

- A. Joint Sealants:
- B. ASJ Flashing Sealants, and Vinyl, PVDC, and PVC Jacket Flashing Sealants:
 - 1. Products: Subject to compliance with requirements, provide one of the following:
 - a. Childers Products, Division of ITW; CP-76.
 - 2. Materials shall be compatible with insulation materials, jackets, and substrates.
 - 3. Fire- and water-resistant, flexible, elastomeric sealant.
 - 4. Service Temperature Range: Minus 40 to plus 250 deg F.
 - 5. Color: White.
 - 6. For indoor applications, use sealants that have a VOC content of 250 g/L or less when calculated according to 40 CFR 59, Subpart D (EPA Method 24).

2.7 FACTORY-APPLIED JACKETS

- A. Insulation system schedules indicate factory-applied jackets on various applications. When factory-applied jackets are indicated, comply with the following:
 - 1. ASJ: White, kraft-paper, fiberglass-reinforced scrim with aluminum-foil backing; complying with ASTM C 1136, Type I.
 - 2. ASJ-SSL: ASJ with self-sealing, pressure-sensitive, acrylic-based adhesive covered by a removable protective strip; complying with ASTM C 1136, Type I.
 - 3. FSK Jacket: Aluminum-foil, fiberglass-reinforced scrim with kraft-paper backing; complying with ASTM C 1136, Type II.

2.8 TAPES

- A. ASJ Tape: White vapor-retarder tape matching factory-applied jacket with acrylic adhesive, complying with ASTM C 1136.
 - 1. Products: Subject to compliance with requirements, provide one of the following:
 - a. Avery Dennison Corporation, Specialty Tapes Division; Fasson 0835.
 - b. Compac Corp.; 104 and 105.
 - c. Ideal Tape Co., Inc., an American Biltrite Company; 428 AWF ASJ.
 - d. Venture Tape; 1540 CW Plus, 1542 CW Plus, and 1542 CW Plus/SQ.
 - 2. Width: 3 inches.
 - 3. Thickness: 11.5 mils.
 - 4. Adhesion: 90 ounces force/inch in width.
 - 5. Elongation: 2 percent.
 - 6. Tensile Strength: 40 lbf/inch in width.
 - 7. ASJ Tape Disks and Squares: Precut disks or squares of ASJ tape.
- B. PVC Tape: White vapor-retarder tape matching field-applied PVC jacket with acrylic adhesive. Suitable for indoor and outdoor applications.
 - 1. Products: Subject to compliance with requirements, provide one of the following:
 - a. Avery Dennison Corporation, Specialty Tapes Division; Fasson 0555.
 - b. Compac Corp.; 130.
 - c. Ideal Tape Co., Inc., an American Biltrite Company; 370 White PVC tape.
 - d. Venture Tape; 1506 CW NS.
 - 2. Width: 2 inches.
 - 3. Thickness: 6 mils.
 - 4. Adhesion: 64 ounces force/inch in width.
 - 5. Elongation: 500 percent.
 - 6. Tensile Strength: 18 lbf/inch in width.

2.9 SECUREMENTS

- A. Bands:

1. Products: Subject to compliance with requirements, provide one of the following:
 - a. Childers Products; Bands.
 - b. PABCO Metals Corporation; Bands.
 - c. RPR Products, Inc.; Bands.
 2. Aluminum: ASTM B 209, Alloy 3003, 3005, 3105, or 5005; Temper H-14, 0.020 inch thick, 1/2 inch wide with wing or closed seal.
 3. Springs: Twin spring set constructed of stainless steel with ends flat and slotted to accept metal bands. Spring size determined by manufacturer for application.
- B. Staples: Outward-clinching insulation staples, nominal 3/4-inch- wide, stainless steel or Monel.
- C. Wire: 0.080-inch nickel-copper alloy.
1. Manufacturers: Subject to compliance with requirements, provide products by one of the following:
 - a. C & F Wire.
 - b. Childers Products.
 - c. PABCO Metals Corporation.
 - d. RPR Products, Inc.

PART 3 - EXECUTION

3.1 EXAMINATION

- A. Examine substrates and conditions for compliance with requirements for installation and other conditions affecting performance of insulation application.
1. Verify that systems and equipment to be insulated have been tested and are free of defects.
 2. Verify that surfaces to be insulated are clean and dry.
 3. Proceed with installation only after unsatisfactory conditions have been corrected.

3.2 PREPARATION

- A. Surface Preparation: Clean and dry surfaces to receive insulation. Remove materials that will adversely affect insulation application.
- B. Surface Preparation: Clean and prepare surfaces to be insulated. Before insulating, apply a corrosion coating to insulated surfaces as follows:
1. Stainless Steel: Coat 300 series stainless steel with an epoxy primer 5 mils thick and an epoxy finish 5 mils thick if operating in a temperature range between 140 and 300 deg F. Consult coating manufacturer for appropriate coating materials and application methods for operating temperature range.
 2. Carbon Steel: Coat carbon steel operating at a service temperature between 32 and 300 deg F with an epoxy coating. Consult coating manufacturer for appropriate coating materials and application methods for operating temperature range.
- C. Coordinate insulation installation with the trade installing heat tracing. Comply with requirements for heat tracing that apply to insulation.
- D. Mix insulating cements with clean potable water; if insulating cements are to be in contact with stainless-steel surfaces, use demineralized water.

3.3 GENERAL INSTALLATION REQUIREMENTS

- A. Install insulation materials, accessories, and finishes with smooth, straight, and even surfaces; free of voids throughout the length of equipment and piping including fittings, valves, and specialties.

- B. Install insulation materials, forms, vapor barriers or retarders, jackets, and thicknesses required for each item of equipment and pipe system as specified in insulation system schedules.
- C. Install accessories compatible with insulation materials and suitable for the service. Install accessories that do not corrode, soften, or otherwise attack insulation or jacket in either wet or dry state.
- D. Install insulation with longitudinal seams at top and bottom of horizontal runs.
- E. Install multiple layers of insulation with longitudinal and end seams staggered.
- F. Do not weld brackets, clips, or other attachment devices to piping, fittings, and specialties.
- G. Keep insulation materials dry during application and finishing.
- H. Install insulation with tight longitudinal seams and end joints. Bond seams and joints with adhesive recommended by insulation material manufacturer.
- I. Install insulation with least number of joints practical.
- J. Where vapor barrier is indicated, seal joints, seams, and penetrations in insulation at hangers, supports, anchors, and other projections with vapor-barrier mastic.
 - 1. Install insulation continuously through hangers and around anchor attachments.
 - 2. For insulation application where vapor barriers are indicated, extend insulation on anchor legs from point of attachment to supported item to point of attachment to structure. Taper and seal ends at attachment to structure with vapor-barrier mastic.
 - 3. Install insert materials and install insulation to tightly join the insert. Seal insulation to insulation inserts with adhesive or sealing compound recommended by insulation material manufacturer.
 - 4. Cover inserts with jacket material matching adjacent pipe insulation. Install shields over jacket, arranged to protect jacket from tear or puncture by hanger, support, and shield.
- K. Apply adhesives, mastics, and sealants at manufacturer's recommended coverage rate and wet and dry film thicknesses.
- L. Install insulation with factory-applied jackets as follows:
 - 1. Draw jacket tight and smooth.
 - 2. Cover circumferential joints with 3-inch- wide strips, of same material as insulation jacket. Secure strips with adhesive and outward clinching staples along both edges of strip, spaced 4 inches o.c.
 - 3. Overlap jacket longitudinal seams at least 1-1/2 inches. Install insulation with longitudinal seams at bottom of pipe. Clean and dry surface to receive self-sealing lap. Staple laps with outward clinching staples along edge at 2 inches o.c.
 - a. For below ambient services, apply vapor-barrier mastic over staples.
 - 4. Cover joints and seams with tape as recommended by insulation material manufacturer to maintain vapor seal.
 - 5. Where vapor barriers are indicated, apply vapor-barrier mastic on seams and joints and at ends adjacent to pipe flanges and fittings.
- M. Cut insulation in a manner to avoid compressing insulation more than 75 percent of its nominal thickness.
- N. Finish installation with systems at operating conditions. Repair joint separations and cracking due to thermal movement.
- O. Repair damaged insulation facings by applying same facing material over damaged areas. Extend patches at least 4 inches beyond damaged areas. Adhere, staple, and seal patches similar to butt joints.
- P. For above ambient services, do not install insulation to the following:
 - 1. Vibration-control devices.
 - 2. Testing agency labels and stamps.
 - 3. Nameplates and data plates.
 - 4. Manholes.

5. Handholes.
6. Cleanouts.

3.4 PENETRATIONS

- A. Insulation Installation at Roof Penetrations: Install insulation continuously through roof penetrations.
 1. Seal penetrations with flashing sealant.
 2. For applications requiring only indoor insulation, terminate insulation above roof surface and seal with joint sealant. For applications requiring indoor and outdoor insulation, install insulation for outdoor applications tightly joined to indoor insulation ends. Seal joint with joint sealant.
 3. Extend jacket of outdoor insulation outside roof flashing at least 2 inches below top of roof flashing.
 4. Seal jacket to roof flashing with flashing sealant.
- B. Insulation Installation at Underground Exterior Wall Penetrations: Terminate insulation flush with sleeve seal. Seal terminations with flashing sealant.
- C. Insulation Installation at Aboveground Exterior Wall Penetrations: Install insulation continuously through wall penetrations.
 1. Seal penetrations with flashing sealant.
 2. For applications requiring only indoor insulation, terminate insulation inside wall surface and seal with joint sealant. For applications requiring indoor and outdoor insulation, install insulation for outdoor applications tightly joined to indoor insulation ends. Seal joint with joint sealant.
 3. Extend jacket of outdoor insulation outside wall flashing and overlap wall flashing at least 2 inches.
 4. Seal jacket to wall flashing with flashing sealant.
- D. Insulation Installation at Interior Wall and Partition Penetrations (That Are Not Fire Rated): Install insulation continuously through walls and partitions.
- E. Insulation Installation at Fire-Rated Wall and Partition Penetrations: Install insulation continuously through penetrations of fire-rated walls and partitions.
 1. Comply with requirements in Division 07 Section "Penetration Firestopping" firestopping and fire-resistive joint sealers.
- F. Insulation Installation at Floor Penetrations:
 1. Pipe: Install insulation continuously through floor penetrations.
 2. Seal penetrations through fire-rated assemblies. Comply with requirements in Division 07 Section "Penetration Firestopping."

3.5 GENERAL PIPE INSULATION INSTALLATION

- A. Requirements in this article generally apply to all insulation materials except where more specific requirements are specified in various pipe insulation material installation articles.
- B. Insulation Installation on Fittings, Valves, Strainers, Flanges, and Unions:
 1. Install insulation over fittings, valves, strainers, flanges, unions, and other specialties with continuous thermal and vapor-retarder integrity, unless otherwise indicated.
 2. Insulate pipe elbows using preformed fitting insulation or mitered fittings made from same material and density as adjacent pipe insulation. Each piece shall be butted tightly against adjoining piece and bonded with adhesive. Fill joints, seams, voids, and irregular surfaces with insulating cement finished to a smooth, hard, and uniform contour that is uniform with adjoining pipe insulation.
 3. Insulate tee fittings with preformed fitting insulation or sectional pipe insulation of same material and thickness as used for adjacent pipe. Cut sectional pipe insulation to fit. Butt each section closely to the next and hold in place with tie wire. Bond pieces with adhesive.
 4. Insulate valves using preformed fitting insulation or sectional pipe insulation of same material, density, and thickness as used for adjacent pipe. Overlap adjoining pipe insulation by not less than two times the thickness of pipe insulation, or one pipe diameter, whichever is thicker. For valves, insulate up to and including the bonnets, valve stuffing-box studs, bolts, and nuts. Fill joints, seams, and irregular surfaces with insulating cement.

5. Insulate strainers using preformed fitting insulation or sectional pipe insulation of same material, density, and thickness as used for adjacent pipe. Overlap adjoining pipe insulation by not less than two times the thickness of pipe insulation, or one pipe diameter, whichever is thicker. Fill joints, seams, and irregular surfaces with insulating cement. Insulate strainers so strainer basket flange or plug can be easily removed and replaced without damaging the insulation and jacket. Provide a removable reusable insulation cover. For below ambient services, provide a design that maintains vapor barrier.
 6. Insulate flanges and unions using a section of oversized preformed pipe insulation. Overlap adjoining pipe insulation by not less than two times the thickness of pipe insulation, or one pipe diameter, whichever is thicker.
 7. Cover segmented insulated surfaces with a layer of finishing cement and coat with a mastic. Install vapor-barrier mastic for below ambient services and a breather mastic for above ambient services. Reinforce the mastic with fabric-reinforcing mesh. Trowel the mastic to a smooth and well-shaped contour.
 8. For services not specified to receive a field-applied jacket except for flexible elastomeric and polyolefin, install fitted PVC cover over elbows, tees, strainers, valves, flanges, and unions. Terminate ends with PVC end caps. Tape PVC covers to adjoining insulation facing using PVC tape.
 9. Stencil or label the outside insulation jacket of each union with the word "UNION." Match size and color of pipe labels.
- C. Insulate instrument connections for thermometers, pressure gages, pressure temperature taps, test connections, flow meters, sensors, switches, and transmitters on insulated pipes, vessels, and equipment. Shape insulation at these connections by tapering it to and around the connection with insulating cement and finish with finishing cement, mastic, and flashing sealant.
- D. Install removable insulation covers at locations indicated. Installation shall conform to the following:
1. Make removable flange and union insulation from sectional pipe insulation of same thickness as that on adjoining pipe. Install same insulation jacket as adjoining pipe insulation.
 2. When flange and union covers are made from sectional pipe insulation, extend insulation from flanges or union long at least two times the insulation thickness over adjacent pipe insulation on each side of flange or union. Secure flange cover in place with stainless-steel or aluminum bands. Select band material compatible with insulation and jacket.
 3. Construct removable valve insulation covers in same manner as for flanges except divide the two-part section on the vertical center line of valve body.
 4. When covers are made from block insulation, make two halves, each consisting of mitered blocks wired to stainless-steel fabric. Secure this wire frame, with its attached insulation, to flanges with tie wire. Extend insulation at least 2 inches over adjacent pipe insulation on each side of valve. Fill space between flange or union cover and pipe insulation with insulating cement. Finish cover assembly with insulating cement applied in two coats. After first coat is dry, apply and trowel second coat to a smooth finish.
 5. Unless a PVC jacket is indicated in field-applied jacket schedules, finish exposed surfaces with a metal jacket.

3.6 MINERAL-FIBER INSULATION INSTALLATION

- A. Insulation Installation on Straight Pipes and Tubes:
1. Secure each layer of preformed pipe insulation to pipe with wire or bands and tighten bands without deforming insulation materials.
 2. Where vapor barriers are indicated, seal longitudinal seams, end joints, and protrusions with vapor-barrier mastic and joint sealant.
 3. For insulation with factory-applied jackets on above ambient surfaces, secure laps with outward clinched staples at 6 inches o.c.
 4. For insulation with factory-applied jackets on below ambient surfaces, do not staple longitudinal tabs but secure tabs with additional adhesive as recommended by insulation material manufacturer and seal with vapor-barrier mastic and flashing sealant.
- B. Insulation Installation on Pipe Flanges:
1. Install preformed pipe insulation to outer diameter of pipe flange.

2. Make width of insulation section same as overall width of flange and bolts, plus twice the thickness of pipe insulation.
 3. Fill voids between inner circumference of flange insulation and outer circumference of adjacent straight pipe segments with mineral-fiber blanket insulation.
 4. Install jacket material with manufacturer's recommended adhesive, overlap seams at least 1 inch, and seal joints with flashing sealant.
- C. Insulation Installation on Pipe Fittings and Elbows:
1. Install preformed sections of same material as straight segments of pipe insulation when available.
 2. When preformed insulation elbows and fittings are not available, install mitered sections of pipe insulation, to a thickness equal to adjoining pipe insulation. Secure insulation materials with wire or bands.
- D. Insulation Installation on Valves and Pipe Specialties:
1. Install preformed sections of same material as straight segments of pipe insulation when available.
 2. When preformed sections are not available, install mitered sections of pipe insulation to valve body.
 3. Arrange insulation to permit access to packing and to allow valve operation without disturbing insulation.
 4. Install insulation to flanges as specified for flange insulation application.

3.7 FIELD QUALITY CONTROL

- A. Perform tests and inspections.
- B. Tests and Inspections:
1. Inspect pipe, fittings, strainers, and valves, randomly selected by Architect, by removing field-applied jacket and insulation in layers in reverse order of their installation. Extent of inspection shall be limited to three locations of straight pipe, three locations of threaded fittings, three locations of welded fittings, two locations of threaded strainers, two locations of welded strainers, three locations of threaded valves, and three locations of flanged valves for each pipe service defined in the "Piping Insulation Schedule, General" Article.
- C. All insulation applications will be considered defective Work if sample inspection reveals noncompliance with requirements.

END OF SECTION 22 0700

SECTION 22 1116 - DOMESTIC WATER PIPING

PART 1 - GENERAL

1.1 RELATED DOCUMENTS

- A. Drawings and general provisions of the Contract, including General and Supplementary Conditions and Division 01 Specification Sections, apply to this Section.

1.2 SUBMITTALS

- A. Product Data: For the following products:
 - 1. Pipe & Pipe Fittings.
 - 2. Valves
 - 3. Pipe Hangers
- B. Water Samples: Specified in "Cleaning" Article.
- C. Coordination Drawings: For piping in equipment rooms and other congested areas, drawn to scale, on which the following items are shown and coordinated with each other, using input from Installers of the items involved:
 - 1. Fire-suppression-water piping.
 - 2. Domestic water piping.
 - 3. HVAC hydronic piping.
 - 4. HVAC Equipment & Duct.
- D. Field quality-control reports.

1.3 QUALITY ASSURANCE

- A. Piping materials shall bear label, stamp, or other markings of specified testing agency.
- B. Comply with NSF 14 for plastic, potable domestic water piping and components. Include marking "NSF-pw" on piping.
- C. Comply with NSF 61 for potable domestic water piping and components.

1.4 COORDINATION

- A. Coordinate sizes and locations of concrete bases with actual equipment provided.

PART 2 - PRODUCTS

2.1 PIPING MATERIALS

- A. Comply with requirements in "Piping Schedule" Article for applications of pipe, tube, fitting materials, and joining methods for specific services, service locations, and pipe sizes.

2.2 PIPING SCHEDULE

- A. Transition and special fittings with pressure ratings at least equal to piping rating may be used in applications below unless otherwise indicated.
- B. Aboveground domestic water piping shall be the following:
 - 1. Hard copper tube, ASTM B 88, Type L; wrought- copper solder-joint fittings; and soldered joints.
- C. Underground domestic water piping shall be the following:
 - 1. Hard copper tube, ASTM B 88, Type K; wrought- copper solder-joint fittings; and soldered joints.

2.3 VALVE SCHEDULE

- A. Drawings indicate valve types to be used. Where specific valve types are not indicated, the following requirements apply:
 - 1. Shutoff Duty: Use ball valves for piping NPS 2-1/2 and smaller. Use butterfly or ball, or for piping NPS 3 and larger.
 - 2. Throttling Duty: Use ball valves for piping NPS 2 and smaller. Use butterfly or ball valves with flanged ends for piping NPS 2-1/2 and larger.
 - 3. Hot-Water Circulation Piping, Balancing Duty: Calibrated balancing valves.
 - 4. Drain Duty: Hose-end drain valves.

2.4 COPPER TUBE AND FITTINGS

- A. Hard Copper Tube: ASTM B 88, Type L water tube, drawn temper.
 - 1. Cast-Copper Solder-Joint Fittings: ASME B16.18, pressure fittings.
 - 2. Wrought-Copper Solder-Joint Fittings: ASME B16.22, wrought-copper pressure fittings.
 - 3. Bronze Flanges: ASME B16.24, Class 150, with solder-joint ends.
 - 4. Copper Unions: MSS SP-123, cast-copper-alloy, hexagonal-stock body, with ball-and-socket, metal-to-metal seating surfaces, and solder-joint or threaded ends.
 - 5. Copper Pressure-Seal-Joint Fittings:
 - a. Manufacturers: Subject to compliance with requirements, provide products by one of the following:
 - 1) Elkhart Products Corporation; Industrial Division.
 - 2) NIBCO INC.
 - 3) Viega; Plumbing and Heating Systems.
 - b. NPS 2 and Smaller: Wrought-copper fitting with EPDM-rubber O-ring seal in each end.
 - c. NPS 2-1/2 to NPS 4: Cast-bronze or wrought-copper fitting with EPDM-rubber O-ring seal in each end.

2.5 PIPING JOINING MATERIALS

- A. Pipe-Flange Gasket Materials: AWWA C110, rubber, flat face, 1/8 inch thick or ASME B16.21, nonmetallic and asbestos free, unless otherwise indicated; full-face or ring type unless otherwise indicated.
- B. Metal, Pipe-Flange Bolts and Nuts: ASME B18.2.1, carbon steel unless otherwise indicated.
- C. Solder Filler Metals: ASTM B 32, lead-free alloys. Include water-flushable flux according to ASTM B 813.
- D. Brazing Filler Metals: AWS A5.8/A5.8M, BCuP Series, copper-phosphorus alloys for general-duty brazing unless otherwise indicated.

PART 3 - EXECUTION

3.1 PIPING INSTALLATION

- A. Drawing plans, schematics, and diagrams indicate general location and arrangement of domestic water piping. Indicated locations and arrangements are used to size pipe and calculate friction loss, expansion, and other design considerations. Install piping as indicated unless deviations to layout are approved on Coordination Drawings.
- B. Install copper tubing under building slab according to CDA's "Copper Tube Handbook."
- C. Install domestic water piping level with 0.25 percent slope downward toward drain and plumb.
- D. Install piping concealed from view and protected from physical contact by building occupants unless otherwise indicated and except in equipment rooms and service areas.
- E. Install piping above accessible ceilings to allow sufficient space for ceiling panel removal, and coordinate with other services occupying that space.
- F. Install piping adjacent to equipment and specialties to allow service and maintenance.
- G. Install piping to permit valve servicing.
- H. Install nipples, unions, special fittings, and valves with pressure ratings the same as or higher than system pressure rating used in applications below unless otherwise indicated.
- I. Install piping free of sags and bends.
- J. Install fittings for changes in direction and branch connections.
- K. Install unions in copper tubing at final connection to each piece of equipment, machine, and specialty.

3.2 JOINT CONSTRUCTION

- A. Ream ends of pipes and tubes and remove burrs. Bevel plain ends of steel pipe.
- B. Remove scale, slag, dirt, and debris from inside and outside of pipes, tubes, and fittings before assembly.
- C. Threaded Joints: Thread pipe with tapered pipe threads according to ASME B1.20.1. Cut threads full and clean using sharp dies. Ream threaded pipe ends to remove burrs and restore full ID. Join pipe fittings and valves as follows:
 - 1. Apply appropriate tape or thread compound to external pipe threads.
 - 2. Damaged Threads: Do not use pipe or pipe fittings with threads that are corroded or damaged.
- D. Brazed Joints: Join copper tube and fittings according to CDA's "Copper Tube Handbook," "Braze Joints" Chapter.
- E. Soldered Joints: Apply ASTM B 813, water-flushable flux to end of tube. Join copper tube and fittings according to ASTM B 828 or CDA's "Copper Tube Handbook."

3.3 HANGER AND SUPPORT INSTALLATION

- A. Comply with requirements in Division 22 Section "Hangers and Supports for Plumbing Piping and Equipment" for pipe hanger and support products and installation.
 - 1. Vertical Piping: MSS Type 8 or 42, clamps.

2. Individual, Straight, Horizontal Piping Runs:
 - a. 100 Feet and Less: MSS Type 1, adjustable, steel clevis hangers.
 - b. Longer Than 100 Feet: MSS Type 43, adjustable roller hangers.
 - c. Longer Than 100 Feet If Indicated: MSS Type 49, spring cushion rolls.
 3. Multiple, Straight, Horizontal Piping Runs 100 Feet or Longer: MSS Type 44, pipe rolls. Support pipe rolls on trapeze.
 4. Base of Vertical Piping: MSS Type 52, spring hangers.
- B. Support vertical piping and tubing at base and at each floor.
- C. Rod diameter may be reduced one size for double-rod hangers, to a minimum of 3/8 inch.
- D. Install hangers for copper tubing with the following maximum horizontal spacing and minimum rod diameters:
 1. NPS 3/4 and Smaller: 60 inches with 3/8-inch rod.
 2. NPS 1 and NPS 1-1/4: 72 inches with 3/8-inch rod.
 3. NPS 1-1/2 and NPS 2: 96 inches with 3/8-inch rod.
 4. NPS 2-1/2: 108 inches with 1/2-inch rod.
 5. NPS 3 to NPS 5: 10 feet with 1/2-inch rod.
 6. NPS 6: 10 feet with 5/8-inch rod.
 7. NPS 8: 10 feet with 3/4-inch rod.
- E. Install supports for vertical copper tubing every 10 feet.
- F. Support piping and tubing not listed in this article according to MSS SP-69 and manufacturer's written instructions.

3.4 CONNECTIONS

- A. Drawings indicate general arrangement of piping, fittings, and specialties.
- B. Install piping adjacent to equipment and machines to allow service and maintenance.
- C. Connect domestic water piping to exterior water-service piping. Use transition fitting to join dissimilar piping materials.
- D. Connect domestic water piping to water-service piping with shutoff valve; extend and connect to the following:
 1. Plumbing Fixtures: Cold- and hot-water supply piping in sizes indicated, but not smaller than required by plumbing code. Comply with requirements in Division 22 plumbing fixture Sections for connection sizes.
 2. Equipment: Cold- and hot-water supply piping as indicated, but not smaller than equipment connections. Provide shutoff valve and union for each connection. Use flanges instead of unions for NPS 2-1/2 and larger.

3.5 ESCUTCHEON INSTALLATION

- A. Refer to Specification section 220500

3.6 IDENTIFICATION

- A. Identify system components. Comply with requirements in Division 22 Section "Identification for Plumbing Piping and Equipment" for identification materials and installation.
- B. Label pressure piping with system operating pressure.

3.7 FIELD QUALITY CONTROL

- A. Perform tests and inspections.
- B. Piping Inspections:
 - 1. Do not enclose, cover, or put piping into operation until it has been inspected and approved by authorities having jurisdiction.
 - 2. During installation, notify authorities having jurisdiction at least one day before inspection must be made. Perform tests specified below in presence of authorities having jurisdiction:
 - a. Roughing-in Inspection: Arrange for inspection of piping before concealing or closing-in after roughing-in and before setting fixtures.
 - b. Final Inspection: Arrange final inspection for authorities having jurisdiction to observe tests specified below and to ensure compliance with requirements.
 - 3. Reinspection: If authorities having jurisdiction find that piping will not pass tests or inspections, make required corrections and arrange for reinspection.
 - 4. Reports: Prepare inspection reports and have them signed by authorities having jurisdiction.
- C. Piping Tests:
 - 1. Fill domestic water piping. Check components to determine that they are not air bound and that piping is full of water.
 - 2. Test for leaks and defects in new piping and parts of existing piping that have been altered, extended, or repaired. If testing is performed in segments, submit a separate report for each test, complete with diagram of portion of piping tested.
 - 3. Leave new, altered, extended, or replaced domestic water piping uncovered and unconcealed until it has been tested and approved. Expose work that was covered or concealed before it was tested.
 - 4. Cap and subject piping to static water pressure of 50 psig above operating pressure, without exceeding pressure rating of piping system materials. Isolate test source and allow to stand for four hours. Leaks and loss in test pressure constitute defects that must be repaired.
 - 5. Repair leaks and defects with new materials and retest piping or portion thereof until satisfactory results are obtained.
 - 6. Prepare reports for tests and for corrective action required.
- D. Domestic water piping will be considered defective if it does not pass tests and inspections.
- E. Prepare test and inspection reports.

3.8 ADJUSTING

- A. Perform the following adjustments before operation:
 - 1. Close drain valves, hydrants, and hose bibbs.
 - 2. Open shutoff valves to fully open position.
 - 3. Open throttling valves to proper setting.
 - 4. Adjust balancing valves in hot-water-circulation return piping to provide adequate flow.
 - a. Manually adjust ball-type balancing valves in hot-water-circulation return piping to provide flow of hot water in each branch.
 - b. Adjust calibrated balancing valves to flows indicated.
 - 5. Remove plugs used during testing of piping and for temporary sealing of piping during installation.
 - 6. Remove and clean strainer screens. Close drain valves and replace drain plugs.
 - 7. Remove filter cartridges from housings and verify that cartridges are as specified for application where used and are clean and ready for use.
 - 8. Check plumbing specialties and verify proper settings, adjustments, and operation.

3.9 CLEANING

- A. Clean and disinfect potable domestic water piping as follows:
 - 1. Purge new piping and parts of existing piping that have been altered, extended, or repaired before using.

2. Use purging and disinfecting procedures prescribed by authorities having jurisdiction; if methods are not prescribed, use procedures described in either AWWA C651 or AWWA C652 or follow procedures described below:
 - a. Flush piping system with clean, potable water until dirty water does not appear at outlets.
 - b. Fill and isolate system according to either of the following:
 - 1) Fill system or part thereof with water/chlorine solution with at least 50 ppm of chlorine. Isolate with valves and allow to stand for 24 hours.
 - 2) Fill system or part thereof with water/chlorine solution with at least 200 ppm of chlorine. Isolate and allow to stand for three hours.
 - c. Flush system with clean, potable water until no chlorine is in water coming from system after the standing time.
 - d. Submit water samples in sterile bottles to authorities having jurisdiction. Repeat procedures if biological examination shows contamination.

END OF SECTION 22 1116

SECTION 22 1316 - SANITARY WASTE & VENT PIPING

PART 1 - GENERAL

1.1 RELATED DOCUMENTS

- A. Drawings and general provisions of the Contract, including General and Supplementary Conditions and Division 01 Specification Sections, apply to this Section.

1.2 SUMMARY

- A. This Section includes the following for soil, waste, and vent piping inside the building:
 - 1. Pipe, tube, and fittings.
 - 2. Special pipe fittings.

1.3 DEFINITIONS

- A. ABS: Acrylonitrile-butadiene-styrene plastic.
- B. EPDM: Ethylene-propylene-diene terpolymer rubber.
- C. LLDPE: Linear, low-density polyethylene plastic.
- D. NBR: Acrylonitrile-butadiene rubber.
- E. PE: Polyethylene plastic.
- F. PVC: Polyvinyl chloride plastic.
- G. TPE: Thermoplastic elastomer.

1.4 PERFORMANCE REQUIREMENTS

- A. Components and installation shall be capable of withstanding the following minimum working pressure, unless otherwise indicated:
 - 1. Soil, Waste, and Vent Piping: 10-foot head of water.

1.5 SUBMITTALS

- A. Product Data: For pipe, tube, fittings, and couplings.
- B. Field quality-control inspection and test reports.

1.6 QUALITY ASSURANCE

- A. Piping materials shall bear label, stamp, or other markings of specified testing agency.
- B. Comply with NSF 14, "Plastics Piping Systems Components and Related Materials," for plastic piping components. Include marking with "NSF-dwv" for plastic drain, waste, and vent piping; "NSF-drain" for

plastic drain piping; "NSF-tubular" for plastic continuous waste piping; and "NSF-sewer" for plastic sewer piping.

PART 2 - PRODUCTS

2.1 MANUFACTURERS

- A. In other Part 2 articles where titles below introduce lists, the following requirements apply to product selection:
1. Manufacturers: Subject to compliance with requirements, provide products by one of the manufacturers specified.

2.2 PIPING APPLICATIONS

- A. Aboveground, soil and waste NPS 6 and smaller shall be the following:
1. Schedule 40 PVC pipe and fittings.
- B. Aboveground, vent piping NPS 4 and smaller shall be the following:
1. Schedule 40 PVC pipe and fittings.
- C. Underground, soil, waste, and vent and roof drain piping NPS 6 and smaller shall be the following:
1. Schedule 40 PVC pipe and fittings except where specified to be cast iron.
 2. Standard weight cast iron pipe and fittings with hub joints where specified.

2.3 PIPING MATERIALS

- A. Refer to Part 3 "Piping Applications" Article for applications of pipe, tube, fitting, and joining materials.

2.4 PVC PIPE AND FITTINGS

- A. Solid-Wall PVC Pipe: ASTM D 2665, drain, waste, and vent.
- B. PVC Socket Fittings: ASTM D 2665, made to ASTM D 3311, drain, waste, and vent patterns and to fit Schedule 40 pipe.
- C. Adhesive Primer: ASTM F 656.
1. Adhesive primer shall have a VOC content of 550 g/L or less when calculated according to 40 CFR 59, Subpart D (EPA Method 24).
 2. Adhesive primer shall comply with the testing and product requirements of the California Department of Health Services' "Standard Practice for the Testing of Volatile Organic Emissions from Various Sources Using Small-Scale Environmental Chambers."
- D. Solvent Cement: ASTM D 2564.
1. PVC solvent cement shall have a VOC content of 510 g/L or less when calculated according to 40 CFR 59, Subpart D (EPA Method 24).
 2. Solvent cement shall comply with the testing and product requirements of the California Department of Health Services' "Standard Practice for the Testing of Volatile Organic Emissions from Various Sources Using Small-Scale Environmental Chambers."

2.5 HUB-AND-SPIGOT, CAST-IRON SOIL PIPE AND FITTINGS

- A. Pipe and Fittings: ASTM A 74, Service and Extra-Heavy class(es).

- B. Gaskets: ASTM C 564, rubber.
- C. Calking Materials: ASTM B 29, pure lead and oakum or hemp fiber.

2.6 HUBLESS CAST-IRON SOIL PIPE AND FITTINGS

- A. Pipe and Fittings: ASTM A 888 or CISPI 301.
- B. Shielded Couplings: ASTM C 1277 assembly of metal shield or housing, corrosion-resistant fasteners, and rubber sleeve with integral, center pipe stop.
 - 1. Standard, Shielded, Stainless-Steel Couplings: CISPI 310, with stainless-steel corrugated shield; stainless-steel bands and tightening devices; and ASTM C 564, rubber sleeve.
 - a. Manufacturers:
 - 1) ANACO.
 - 2) Fernco, Inc.
 - 3) Ideal Div.; Stant Corp.
 - 4) Mission Rubber Co.
 - 5) Tyler Pipe; Soil Pipe Div.
 - 2. Shielded, Stainless-Steel Couplings: With stainless-steel shield, stainless-steel bands and tightening devices, and ASTM C 564, rubber sleeve.
 - a. Manufacturers:
 - 1) ANACO.
 - 2) Clamp-All Corp.
 - 3) Ideal Div.; Stant Corp.
 - 4) Mission Rubber Co.
 - 5) Tyler Pipe; Soil Pipe Div.

PART 3 - EXECUTION

3.1 PIPING INSTALLATION

- A. Basic piping installation requirements are specified in Division 22 Section "Common Work Results for Plumbing."
- B. Install cleanouts at grade and extend to where building sanitary drains connect to building sanitary sewers.
- C. Install cleanout fitting with closure plug inside the building in sanitary force-main piping.
- D. Install cast-iron soil piping according to CISPI's "Cast Iron Soil Pipe and Fittings Handbook," Chapter IV, "Installation of Cast Iron Soil Pipe and Fittings."
 - 1. Install encasement on underground piping according to ASTM A 674 or AWWA C105.
- E. Make changes in direction for soil and waste drainage and vent piping using appropriate branches, bends, and long-sweep bends. Sanitary tees and short-sweep 1/4 bends may be used on vertical stacks if change in direction of flow is from horizontal to vertical. Use long-turn, double Y-branch and 1/8-bend fittings if 2 fixtures are installed back to back or side by side with common drain pipe. Straight tees, elbows, and crosses may be used on vent lines. Do not change direction of flow more than 90 degrees. Use proper size of standard increasers and reducers if pipes of different sizes are connected. Reducing size of drainage piping in direction of flow is prohibited.
- F. Lay buried building drainage piping beginning at low point of each system. Install true to grades and alignment indicated, with unbroken continuity of invert. Place hub ends of piping upstream. Install required gaskets according to manufacturer's written instructions for use of lubricants, cements, and other installation requirements. Maintain swab in piping and pull past each joint as completed.

- G. Install soil and waste drainage and vent piping at the following minimum slopes, unless otherwise indicated:
 - 1. Building Sanitary Drain: 2 percent downward in direction of flow for piping NPS 3 and smaller; 1 percent downward in direction of flow for piping NPS 4 and larger.
 - 2. Horizontal Sanitary Drainage Piping: 2 percent downward in direction of flow.
 - 3. Vent Piping: 1 percent down toward vertical fixture vent or toward vent stack.
- H. Sleeves are not required for cast-iron soil piping passing through concrete slabs-on-grade if slab is without membrane waterproofing.
- I. Do not enclose, cover, or put piping into operation until it is inspected and approved by authorities having jurisdiction.

3.2 JOINT CONSTRUCTION

- A. Basic piping joint construction requirements are specified in Division 22 Section "Common Work Results for Plumbing."
- B. Join hub-and-spigot, cast-iron soil piping with gasket joints according to CISPI's "Cast Iron Soil Pipe and Fittings Handbook" for compression joints.
- C. Join hubless cast-iron soil piping according to CISPI 310 and CISPI's "Cast Iron Soil Pipe and Fittings Handbook" for hubless-coupling joints.

3.3 HANGER AND SUPPORT INSTALLATION

- A. Pipe hangers and supports are specified in Division 22 Section "Hangers and Supports for Plumbing Piping and Equipment." Install the following:
 - 1. Vertical Piping: MSS Type 8 or Type 42, clamps.
 - 2. Install individual, straight, horizontal piping runs according to the following:
 - a. 100 Feet and Less: MSS Type 1, adjustable, steel clevis hangers.
 - b. Longer Than 100 Feet: MSS Type 43, adjustable roller hangers.
 - c. Longer Than 100 Feet, if Indicated: MSS Type 49, spring cushion rolls.
 - 3. Multiple, Straight, Horizontal Piping Runs 100 Feet or Longer: MSS Type 44, pipe rolls. Support pipe rolls on trapeze.
 - 4. Base of Vertical Piping: MSS Type 52, spring hangers.
- B. Install supports according to Division 22 Section "Hangers and Supports for Plumbing Piping and Equipment."
- C. Support vertical piping and tubing at base and at each floor.
- D. Rod diameter may be reduced 1 size for double-rod hangers, with 3/8-inch minimum rods.
- E. Install hangers for cast-iron soil piping with the following maximum horizontal spacing and minimum rod diameters:
 - 1. NPS 1-1/2 and NPS 2: 60 inches with 3/8-inch rod.
 - 2. NPS 3: 60 inches with 1/2-inch rod.
 - 3. NPS 4 and NPS 5: 60 inches with 5/8-inch rod.
 - 4. NPS 6: 60 inches with 3/4-inch rod.
 - 5. NPS 8 to NPS 12: 60 inches with 7/8-inch rod.
- F. Install supports for vertical cast-iron soil piping every 15 feet.

3.4 CONNECTIONS

- A. Drawings indicate general arrangement of piping, fittings, and specialties.
- B. Connect soil and waste piping to exterior sanitary sewerage piping. Use transition fitting to join dissimilar piping materials.
- C. Connect drainage and vent piping to the following:
 - 1. Plumbing Fixtures: Connect drainage piping in sizes indicated, but not smaller than required by plumbing code.
 - 2. Plumbing Fixtures and Equipment: Connect atmospheric vent piping in sizes indicated, but not smaller than required by authorities having jurisdiction.
 - 3. Plumbing Specialties: Connect drainage and vent piping in sizes indicated, but not smaller than required by plumbing code.
 - 4. Equipment: Connect drainage piping as indicated. Provide shutoff valve, if indicated, and union for each connection. Use flanges instead of unions for connections NPS 2-1/2 and larger.

3.5 FIELD QUALITY CONTROL

- A. During installation, notify authorities having jurisdiction at least 24 hours before inspection must be made. Perform tests specified below in presence of authorities having jurisdiction.
 - 1. Roughing-in Inspection: Arrange for inspection of piping before concealing or closing-in after roughing-in and before setting fixtures.
 - 2. Final Inspection: Arrange for final inspection by authorities having jurisdiction to observe tests specified below and to ensure compliance with requirements.
- B. Reinspection: If authorities having jurisdiction find that piping will not pass test or inspection, make required corrections and arrange for reinspection.
- C. Reports: Prepare inspection reports and have them signed by authorities having jurisdiction.
- D. Test sanitary drainage and vent piping according to procedures of authorities having jurisdiction or, in absence of published procedures, as follows:
 - 1. Test for leaks and defects in new piping and parts of existing piping that have been altered, extended, or repaired. If testing is performed in segments, submit separate report for each test, complete with diagram of portion of piping tested.
 - 2. Leave uncovered and unconcealed new, altered, extended, or replaced drainage and vent piping until it has been tested and approved. Expose work that was covered or concealed before it was tested.
 - 3. Roughing-in Plumbing Test Procedure: Test drainage and vent piping, except outside leaders, on completion of roughing-in. Close openings in piping system and fill with water to point of overflow, but not less than 10-foot head of water. From 15 minutes before inspection starts to completion of inspection, water level must not drop. Inspect joints for leaks.
 - 4. Finished Plumbing Test Procedure: After plumbing fixtures have been set and traps filled with water, test connections and prove they are gastight and watertight. Plug vent-stack openings on roof and building drains where they leave building. Introduce air into piping system equal to pressure of 1-inch wg. Use U-tube or manometer inserted in trap of water closet to measure this pressure. Air pressure must remain constant without introducing additional air throughout period of inspection. Inspect plumbing fixture connections for gas and water leaks.
 - 5. Repair leaks and defects with new materials and retest piping, or portion thereof, until satisfactory results are obtained.
 - 6. Prepare reports for tests and required corrective action.
- E. Test force-main piping according to procedures of authorities having jurisdiction or, in absence of published procedures, as follows:
 - 1. Leave uncovered and unconcealed new, altered, extended, or replaced force-main piping until it has been tested and approved. Expose work that was covered or concealed before it was tested.

2. Cap and subject piping to static-water pressure of 50 psig above operating pressure, without exceeding pressure rating of piping system materials. Isolate test source and allow to stand for four hours. Leaks and loss in test pressure constitute defects that must be repaired.
3. Repair leaks and defects with new materials and retest piping, or portion thereof, until satisfactory results are obtained.
4. Prepare reports for tests and required corrective action.

3.6 CLEANING

- A. Clean interior of piping. Remove dirt and debris as work progresses.
- B. Protect drains during remainder of construction period to avoid clogging with dirt and debris and to prevent damage from traffic and construction work.
- C. Place plugs in ends of uncompleted piping at end of day and when work stops.

END OF SECTION 22 1316

SECTION 221319 - SANITARY WASTE PIPING SPECIALTIES

PART 1 - GENERAL

1.1 RELATED DOCUMENTS

- A. Drawings and general provisions of the Contract, including General and Supplementary Conditions and Division 01 Specification Sections, apply to this Section.

1.2 SUMMARY

- A. This Section includes the following sanitary drainage piping specialties:
 1. Cleanouts.
 2. Floor drains.
 3. Roof flashing assemblies.
 4. Miscellaneous sanitary drainage piping specialties.
 5. Flashing materials.

1.3 DEFINITIONS

- A. ABS: Acrylonitrile-butadiene-styrene plastic.
- B. FOG: Fats, oils, and greases.
- C. FRP: Fiberglass-reinforced plastic.
- D. HDPE: High-density polyethylene plastic.
- E. PE: Polyethylene plastic.
- F. PP: Polypropylene plastic.
- G. PVC: Polyvinyl chloride plastic.

1.4 SUBMITTALS

- A. Product Data: For each type of product.
- B. Field quality-control test reports.
- C. Operation and Maintenance Data: For drainage piping specialties to include in emergency, operation, and maintenance manuals.

1.5 QUALITY ASSURANCE

- A. Drainage piping specialties shall bear label, stamp, or other markings of specified testing agency.
- B. Electrical Components, Devices, and Accessories: Listed and labeled as defined in NFPA 70, Article 100, by a testing agency acceptable to authorities having jurisdiction, and marked for intended use.

- C. Comply with NSF 14, "Plastics Piping Components and Related Materials," for plastic sanitary piping specialty components.

1.6 COORDINATION

- A. Coordinate size and location of concrete bases. Cast anchor-bolt inserts into bases. Concrete, reinforcement, and formwork requirements are specified in Division 03.
- B. Coordinate size and location of roof penetrations.

PART 2 - PRODUCTS

2.1 CLEANOUTS

A. Metal Floor Cleanouts:

1. Manufacturers: Subject to compliance with requirements, provide products by one of the following:
 - a. Josam Company; Josam Div.
 - b. Smith, Jay R. Mfg. Co.; Division of Smith Industries, Inc.
 - c. Tyler Pipe; Wade Div.
 - d. Watts Drainage Products Inc.
 - e. Zurn Plumbing Products Group; Light Commercial Operation.
 - f. Zurn Plumbing Products Group; Specification Drainage Operation.
 - g. Josam Company; Josam Div.
 - h. Smith, Jay R. Mfg. Co.; Division of Smith Industries, Inc.
 - i. Josam Company; Blucher-Josam Div.
2. Standard: ASME A112.36.2M for threaded, adjustable housing cleanout.
3. Size: Same as connected branch.
4. Type: Threaded, adjustable housing.
5. Body or Ferrule: Cast iron.
6. Clamping Device: Not required.
7. Outlet Connection: Spigot.
8. Closure: Brass plug with tapered threads.
9. Adjustable Housing Material: Cast iron with threads.
10. Frame and Cover Material and Finish: Nickel-bronze, copper alloy.
11. Frame and Cover Shape: Square.
12. Top Loading Classification: Medium Duty.
13. Riser: ASTM A 74, Service class, cast-iron drainage pipe fitting and riser to cleanout.
14. Standard: ASME A112.3.1.
15. Size: Same as connected branch.

B. Cast-Iron Wall Cleanouts:

1. Manufacturers: Subject to compliance with requirements, provide products by one of the following:
 - a. Josam Company; Josam Div.
 - b. MIFAB, Inc.
 - c. Smith, Jay R. Mfg. Co.; Division of Smith Industries, Inc.
 - d. Tyler Pipe; Wade Div.
 - e. Watts Drainage Products Inc.
 - f. Zurn Plumbing Products Group; Specification Drainage Operation.
2. Standard: ASME A112.36.2M. Include wall access.
3. Size: Same as connected drainage piping.
4. Body: Hubless, cast-iron soil pipe test tee as required to match connected piping.
5. Closure: Countersunk, drilled-and-threaded cast-iron plug.
6. Closure Plug Size: Same as or not more than one size smaller than cleanout size.
7. Wall Access: Round, flat, chrome-plated brass or stainless-steel cover plate with screw.

2.2 FLOOR DRAINS

- A. Cast-Iron Floor Drains:
1. Manufacturers: Subject to compliance with requirements, provide products by one of the following:
 - a. Commercial Enameling Co.
 - b. Josam Company; Josam Div.
 - c. MIFAB, Inc.
 - d. Prier Products, Inc.
 - e. Smith, Jay R. Mfg. Co.; Division of Smith Industries, Inc.
 - f. Tyler Pipe; Wade Div.
 - g. Watts Drainage Products Inc.
 - h. Zurn Plumbing Products Group; Light Commercial Operation.
 - i. Zurn Plumbing Products Group; Specification Drainage Operation.
 2. Standard: ASME A112.6.3.
 3. Pattern: Floor drain.
 4. Body Material: Gray iron.
 5. Seepage Flange: Required.
 6. Anchor Flange: Required.
 7. Clamping Device: Required.
 8. Outlet: Bottom.
 9. Coating on Interior and Exposed Exterior Surfaces: Acid-resistant enamel.
 10. Top or Strainer Material: Nickel bronze
 11. Top Shape: Square.
 12. Dimensions of Top or Strainer: 6"
 13. Top Loading Classification: Medium Duty.
 14. Trap Material: Cast iron.
 15. Trap Pattern: Standard P-trap.

2.3 MISCELLANEOUS SANITARY DRAINAGE PIPING SPECIALTIES

- A. Open (Hub) Drains:
1. Description: Shop or field fabricate from ASTM A 74, Service class, hub-and-spigot, cast-iron, soil-pipe fittings. Include P-trap, hub-and-spigot riser section; and where required, increaser fitting joined with ASTM C 564, rubber gaskets.
 2. Size: Same as connected waste piping with increaser fitting of size indicated.
- B. Deep-Seal Traps:
1. Description: Cast-iron or bronze casting, with inlet and outlet matching connected piping and cleanout trap-seal primer valve connection.
 2. Size: Same as connected waste piping.
 - a. NPS 2: 4-inch- minimum water seal.
 - b. NPS 2-1/2 and Larger: 5-inch- minimum water seal.
- C. Floor-Drain, Trap-Seal Primer Fittings:
1. Description: Cast iron, with threaded inlet and threaded or spigot outlet, and trap-seal primer valve connection.
 2. Size: Same as floor drain outlet with NPS 1/2 side inlet.
- D. Air-Gap Fittings:
1. Standard: ASME A112.1.2, for fitting designed to ensure fixed, positive air gap between installed inlet and outlet piping.
 2. Body: Bronze or cast iron.
 3. Inlet: Opening in top of body.
 4. Outlet: Larger than inlet.
 5. Size: Same as connected waste piping and with inlet large enough for associated indirect waste piping.
- E. Sleeve Flashing Device:

1. Description: Manufactured, cast-iron fitting, with clamping device, that forms sleeve for pipe floor penetrations of floor membrane. Include galvanized-steel pipe extension in top of fitting that will extend 1 inch above finished floor and galvanized-steel pipe extension in bottom of fitting that will extend through floor slab.
2. Size: As required for close fit to riser or stack piping.

2.4 FLASHING MATERIALS

- A. Lead Sheet: ASTM B 749, Type L51121, copper bearing, with the following minimum weights and thicknesses, unless otherwise indicated:
 1. General Use: 4.0-lb/sq. ft., 0.0625-inch thickness.
 2. Vent Pipe Flashing: 3.0-lb/sq. ft., 0.0469-inch thickness.
 3. Burning: 6-lb/sq. ft., 0.0938-inch thickness.
- B. Copper Sheet: ASTM B 152/B 152M, of the following minimum weights and thicknesses, unless otherwise indicated:
 1. General Applications: 12 oz./sq. ft..
 2. Vent Pipe Flashing: 8 oz./sq. ft..
- C. Zinc-Coated Steel Sheet: ASTM A 653/A 653M, with 0.20 percent copper content and 0.04-inch minimum thickness, unless otherwise indicated. Include G90 hot-dip galvanized, mill-phosphatized finish for painting if indicated.
- D. Elastic Membrane Sheet: ASTM D 4068, flexible, chlorinated polyethylene, 40-mil minimum thickness.
- E. Fasteners: Metal compatible with material and substrate being fastened.
- F. Metal Accessories: Sheet metal strips, clamps, anchoring devices, and similar accessory units required for installation; matching or compatible with material being installed.
- G. Solder: ASTM B 32, lead-free alloy.
- H. Bituminous Coating: SSPC-Paint 12, solvent-type, bituminous mastic.

PART 3 - EXECUTION

3.1 INSTALLATION

- A. Refer to Division 22 Section "Common Work Results for Plumbing" for piping joining materials, joint construction, and basic installation requirements.
- B. Install backwater valves in building drain piping. For interior installation, provide cleanout deck plate flush with floor and centered over backwater valve cover, and of adequate size to remove valve cover for servicing.
- C. Install cleanouts in aboveground piping and building drain piping according to the following, unless otherwise indicated:
 1. Size same as drainage piping up to NPS 4. Use NPS 4 for larger drainage piping unless larger cleanout is indicated.
 2. Locate at each change in direction of piping greater than 45 degrees.
 3. Locate at minimum intervals of 50 feet for piping NPS 4 and smaller and 100 feet for larger piping.
 4. Locate at base of each vertical soil and waste stack.
- D. For floor cleanouts for piping below floors, install cleanout deck plates with top flush with finished floor.

- E. For cleanouts located in concealed piping, install cleanout wall access covers, of types indicated, with frame and cover flush with finished wall.
- F. Install floor drains at low points of surface areas to be drained. Set grates of drains flush with finished floor, unless otherwise indicated.
 - 1. Position floor drains for easy access and maintenance.
 - 2. Set floor drains below elevation of surrounding finished floor to allow floor drainage. Set with grates depressed according to the following drainage area radii:
 - a. Radius, 30 Inches or Less: Equivalent to 1 percent slope, but not less than 1/4-inch total depression.
 - b. Radius, 30 to 60 Inches: Equivalent to 1 percent slope.
 - c. Radius, 60 Inches or Larger: Equivalent to 1 percent slope, but not greater than 1-inch total depression.
 - 3. Install floor-drain flashing collar or flange so no leakage occurs between drain and adjoining flooring. Maintain integrity of waterproof membranes where penetrated.
 - 4. Install individual traps for floor drains connected to sanitary building drain, unless otherwise indicated.
- G. Install trench drains at low points of surface areas to be drained. Set grates of drains flush with finished surface, unless otherwise indicated.
- H. Assemble and install ASME A112.3.1, stainless-steel channel drainage systems according to ASME A112.3.1. Install on support devices so that top will be flush with surface.
- I. Assemble non-ASME A112.3.1, stainless-steel channel drainage system components according to manufacturer's written instructions. Install on support devices so that top will be flush with adjacent surface.
- J. Assemble FRP channel drainage system components according to manufacturer's written instructions. Install on support devices so that top will be flush with adjacent surface.
- K. Assemble plastic channel drainage system components according to manufacturer's written instructions. Install on support devices so that top will be flush with adjacent surface.
- L. Install fixture air-admittance valves on fixture drain piping.
- M. Install air-admittance-valve wall boxes recessed in wall.
- N. Install roof flashing assemblies on sanitary stack vents and vent stacks that extend through roof.
- O. Install flashing fittings on sanitary stack vents and vent stacks that extend through roof.
- P. Install through-penetration firestop assemblies in plastic stacks at floor penetrations.
- Q. Assemble open drain fittings and install with top of hub 2 inches above floor.
- R. Install deep-seal traps on floor drains and other waste outlets, if indicated.
- S. Install floor-drain, trap-seal primer fittings on inlet to floor drains that require trap-seal primer connection.
 - 1. Exception: Fitting may be omitted if trap has trap-seal primer connection.
 - 2. Size: Same as floor drain inlet.
- T. Install air-gap fittings on draining-type backflow preventers and on indirect-waste piping discharge into sanitary drainage system.
- U. Install sleeve flashing device with each riser and stack passing through floors with waterproof membrane.
- V. Install vent caps on each vent pipe passing through roof.

- W. Install frost-resistant vent terminals on each vent pipe passing through roof. Maintain 1-inch clearance between vent pipe and roof substrate.
- X. Install expansion joints on vertical stacks and conductors. Position expansion joints for easy access and maintenance.
- Y. Install frost-proof vent caps on each vent pipe passing through roof. Maintain 1-inch clearance between vent pipe and roof substrate.
- Z. Install wood-blocking reinforcement for wall-mounting-type specialties.
- AA. Install traps on plumbing specialty drain outlets. Omit traps on indirect wastes unless trap is indicated.
- BB. Install escutcheons at wall, floor, and ceiling penetrations in exposed finished locations and within cabinets and millwork. Use deep-pattern escutcheons if required to conceal protruding pipe fittings.

3.2 CONNECTIONS

- A. Piping installation requirements are specified in other Division 22 Sections. Drawings indicate general arrangement of piping, fittings, and specialties.
- B. Install piping adjacent to equipment to allow service and maintenance.

3.3 FLASHING INSTALLATION

- A. Fabricate flashing from single piece unless large pans, sumps, or other drainage shapes are required. Join flashing according to the following if required:
 - 1. Lead Sheets: Burn joints of lead sheets 6.0-lb/sq. ft., 0.0938-inch thickness or thicker. Solder joints of lead sheets 4.0-lb/sq. ft., 0.0625-inch thickness or thinner.
 - 2. Copper Sheets: Solder joints of copper sheets.
- B. Install sheet flashing on pipes, sleeves, and specialties passing through or embedded in floors and roofs with waterproof membrane.
 - 1. Pipe Flashing: Sleeve type, matching pipe size, with minimum length of 10 inches, and skirt or flange extending at least 8 inches around pipe.
 - 2. Sleeve Flashing: Flat sheet, with skirt or flange extending at least 8 inches around sleeve.
 - 3. Embedded Specialty Flashing: Flat sheet, with skirt or flange extending at least 8 inches around specialty.
- C. Set flashing on floors and roofs in solid coating of bituminous cement.
- D. Secure flashing into sleeve and specialty clamping ring or device.
- E. Install flashing for piping passing through roofs with counterflashing or commercially made flashing fittings, according to Division 07 Section "Sheet Metal Flashing and Trim."
- F. Extend flashing up vent pipe passing through roofs and turn down into pipe, or secure flashing into cast-iron sleeve having calking recess.
- G. Fabricate and install flashing and pans, sumps, and other drainage shapes.

3.4 FIELD QUALITY CONTROL

- A. Tests and Inspections:

1. Leak Test: After installation, charge system and test for leaks. Repair leaks and retest until no leaks exist.
2. Test and adjust controls and safeties. Replace damaged and malfunctioning controls and equipment.

3.5 PROTECTION

- A. Protect drains during remainder of construction period to avoid clogging with dirt or debris and to prevent damage from traffic or construction work.
- B. Place plugs in ends of uncompleted piping at end of each day or when work stops.

END OF SECTION 221319

SECTION 22 4000 - PLUMBING FIXTURES

PART 1 - GENERAL

1.1 RELATED DOCUMENTS

- A. Drawings and general provisions of the Contract, including General and Supplementary Conditions and Division 01 Specification Sections, apply to this Section.

1.2 SUMMARY

- A. This Section includes the following conventional plumbing fixtures and related components:
 - 1. Faucets for lavatories showers and sinks.
 - 2. Laminar-flow faucet-spout outlets.
 - 3. Flushometers.
 - 4. Toilet seats.
 - 5. Protective shielding guards.
 - 6. Fixture supports.
 - 7. Water closets.
 - 8. Lavatories.
 - 9. Commercial sinks.
- B. Related Sections include the following:
 - 1. Division 10 Section "Toilet, Bath, and Laundry Accessories."
 - 2. Division 22 Section "Domestic Water Piping Specialties" for backflow preventers, floor drains, and specialty fixtures not included in this Section.

1.3 DEFINITIONS

- A. ABS: Acrylonitrile-butadiene-styrene plastic.
- B. Accessible Fixture: Plumbing fixture that can be approached, entered, and used by people with disabilities.
- C. Cast Polymer: Cast-filled-polymer-plastic material. This material includes cultured-marble and solid-surface materials.
- D. Cultured Marble: Cast-filled-polymer-plastic material with surface coating.
- E. Fitting: Device that controls the flow of water into or out of the plumbing fixture. Fittings specified in this Section include supplies and stops, faucets and spouts, shower heads and tub spouts, drains and tailpieces, and traps and waste pipes. Piping and general-duty valves are included where indicated.
- F. FRP: Fiberglass-reinforced plastic.
- G. PMMA: Polymethyl methacrylate (acrylic) plastic.
- H. PVC: Polyvinyl chloride plastic.
- I. Solid Surface: Nonporous, homogeneous, cast-polymer-plastic material with heat-, impact-, scratch-, and stain-resistance qualities.

1.4 SUBMITTALS

- A. Product Data: For each type of plumbing fixture indicated. Include selected fixture and trim, fittings, accessories, appliances, appurtenances, equipment, and supports. Indicate materials and finishes, dimensions, construction details, and flow-control rates.
- B. Shop Drawings: Diagram power, signal, and control wiring.
- C. Operation and Maintenance Data: For plumbing fixtures to include in emergency, operation, and maintenance manuals.
- D. Warranty: Special warranty specified in this Section.

1.5 QUALITY ASSURANCE

- A. Source Limitations: Obtain plumbing fixtures, faucets, and other components of each category through one source from a single manufacturer.
 - 1. Exception: If fixtures, faucets, or other components are not available from a single manufacturer, obtain similar products from other manufacturers specified for that category.
- B. Electrical Components, Devices, and Accessories: Listed and labeled as defined in NFPA 70, Article 100, by a testing agency acceptable to authorities having jurisdiction, and marked for intended use.
- C. Regulatory Requirements: Comply with requirements in ICC A117.1, "Accessible and Usable Buildings and Facilities"; Public Law 90-480, "Architectural Barriers Act"; and Public Law 101-336, "Americans with Disabilities Act"; for plumbing fixtures for people with disabilities.
- D. Regulatory Requirements: Comply with requirements in Public Law 102-486, "Energy Policy Act," about water flow and consumption rates for plumbing fixtures.
- E. NSF Standard: Comply with NSF 61, "Drinking Water System Components--Health Effects," for fixture materials that will be in contact with potable water.
- F. Select combinations of fixtures and trim, faucets, fittings, and other components that are compatible.
- G. Comply with the following applicable standards and other requirements specified for plumbing fixtures:
 - 1. Enameled, Cast-Iron Fixtures: ASME A112.19.1M.
 - 2. Plastic Bathtubs: ANSI Z124.1.
 - 3. Plastic Lavatories: ANSI Z124.3.
 - 4. Plastic Laundry Trays: ANSI Z124.6.
 - 5. Plastic Mop-Service Basins: ANSI Z124.6.
 - 6. Plastic Shower Enclosures: ANSI Z124.2.
 - 7. Plastic Sinks: ANSI Z124.6.
 - 8. Plastic Urinal Fixtures: ANSI Z124.9.
 - 9. Plastic Whirlpool Bathtubs: ANSI Z124.1 and ASME A112.19.7M.
 - 10. Porcelain-Enameled, Formed-Steel Fixtures: ASME A112.19.4M.
 - 11. Slip-Resistant Bathing Surfaces: ASTM F 462.
 - 12. Solid-Surface-Material Lavatories and Sinks: ANSI/ICPA SS-1.
 - 13. Stainless-Steel Commercial, Handwash Sinks: NSF 2 construction.
 - 14. Stainless-Steel Residential Sinks: ASME A112.19.3.
 - 15. Vitreous-China Fixtures: ASME A112.19.2M.
 - 16. Water-Closet, Flush Valve, Tank Trim: ASME A112.19.5.
 - 17. Water-Closet, Flushometer Tank Trim: ASSE 1037.
 - 18. Whirlpool Bathtub Fittings: ASME A112.19.8M.
- H. Comply with the following applicable standards and other requirements specified for lavatory and sink faucets:
 - 1. Backflow Protection Devices for Faucets with Side Spray: ASME A112.18.3M.

2. Backflow Protection Devices for Faucets with Hose-Thread Outlet: ASME A112.18.3M.
3. Diverter Valves for Faucets with Hose Spray: ASSE 1025.
4. Faucets: ASME A112.18.1.
5. Hose-Connection Vacuum Breakers: ASSE 1011.
6. Hose-Coupling Threads: ASME B1.20.7.
7. Integral, Atmospheric Vacuum Breakers: ASSE 1001.
8. NSF Potable-Water Materials: NSF 61.
9. Pipe Threads: ASME B1.20.1.
10. Sensor-Actuated Faucets and Electrical Devices: UL 1951.
11. Supply Fittings: ASME A112.18.1.
12. Brass Waste Fittings: ASME A112.18.2.

- I. Comply with the following applicable standards and other requirements specified for miscellaneous fittings:
 1. Atmospheric Vacuum Breakers: ASSE 1001.
 2. Brass and Copper Supplies: ASME A112.18.1.
 3. Dishwasher Air-Gap Fittings: ASSE 1021.
 4. Manual-Operation Flushometers: ASSE 1037.
 5. Plastic Tubular Fittings: ASTM F 409.
 6. Brass Waste Fittings: ASME A112.18.2.
 7. Sensor-Operation Flushometers: ASSE 1037 and UL 1951.

1.6 WARRANTY

- A. Special Warranties: Manufacturer's standard form in which manufacturer agrees to repair or replace components of whirlpools that fail in materials or workmanship within specified warranty period.
 1. Failures include, but are not limited to, the following:
 - a. Structural failures of unit shell.
 - b. Faulty operation of controls, blowers, pumps, heaters, and timers.
 - c. Deterioration of metals, metal finishes, and other materials beyond normal use.
 2. Warranty Period for Commercial Applications: One year(s) from date of Substantial Completion.

1.7 EXTRA MATERIALS

- A. Furnish extra materials described below that match products installed and that are packaged with protective covering for storage and identified with labels describing contents.
 1. Faucet Washers and O-Rings: Equal to 10 percent of amount of each type and size installed.
 2. Faucet Cartridges and O-Rings: Equal to 5 percent of amount of each type and size installed.
 3. Flushometer Valve, Repair Kits: Equal to 10 percent of amount of each type installed, but no fewer than 3 of each type.
 4. Provide hinged-top wood or metal box, or individual metal boxes, with separate compartments for each type and size of extra materials listed above.
 5. Toilet Seats: Equal to 5 percent of amount of each type installed.

PART 2 - PRODUCTS

2.1 LAVATORY FAUCETS

- A. Lavatory Faucets,:
 1. Manufacturers: Subject to compliance with requirements, provide products by one of the following:
 - a. As specified on the drawings.
 2. Description: Single-control mixing valve. Include hot- and cold-water indicators; coordinate faucet inlets with supplies and fixture holes; coordinate outlet with spout and fixture receptor.
 - a. Body Material: Commercial, solid brass.
 - b. Finish: Polished chrome plate.
 - c. Maximum Flow Rate: 0.5 gpm.
 - d. Centers: 4 inches.

- e. Mounting: Deck, exposed.
- f. Valve Handle(s): Lever.
- g. Spout: Rigid type.
- h. Spout Outlet: Aerator.
- i. Operation: Noncompression, manual.
- j. Drain: Grid.
- k. Tempering Device: Mechanical.

2.2 SINK FAUCETS

A. Sink Faucets,:

1. Manufacturers: Subject to compliance with requirements, provide products by one of the following:
 - a. As specified on the drawings, no substitutions.
2. Description: Include hot- and cold-water indicators; coordinate faucet inlets with supplies and fixture holes; coordinate outlet with spout and fixture receptor. Provide with spray where required by the drawings.
 - a. Body Material: Commercial, solid brass.
 - b. Finish: Polished chrome plate.
 - c. Maximum Flow Rate: 1.0 gpm, unless otherwise indicated.
 - d. Mixing Valve: Single control or Two-lever handle as required by the drawings.
 - e. Centers: 8 inches.
 - f. Mounting: Deck,.
 - g. Handle(s): Lever or Wrist blade as required by the drawings.
 - h. Spout Type: Rigid, solid brass.
 - i. Spout Outlet: Aerator.
 - j. Vacuum Breaker: Not required.
 - k. Operation: Compression, manual (wrist blades); Noncompression, manual (single lever).
 - l. Drain: Basket Strainer.

2.3 FLUSHOMETERS

A. Flushometers,:

1. Manufacturers: Subject to compliance with requirements, provide products by one of the following:
 - a. Sloan Valve Company (no substitutions).
2. Description: Flushometer for urinal and water-closet-type fixture. Include brass body with corrosion-resistant internal components, non-hold-open feature, control stop with check valve, vacuum breaker, copper or brass tubing, and polished chrome-plated finish on exposed parts.
 - a. Internal Design: Diaphragm operation.
 - b. Style: Exposed.
 - c. Inlet Size: NPS 3/4 (urinal); NPS 1 (water closet).
 - d. Trip Mechanism: Oscillating, lever-handle actuator.
 - e. Consumption: 0.5 gal./flush (urinal); 1.6 gal./flush (water closet).

2.4 TOILET SEATS

A. Toilet Seats,:

1. Manufacturers: Subject to compliance with requirements, provide products by one of the following:
 - a. Bemis Manufacturing Company.
 - b. Centoco Manufacturing Corp.
 - c. Church Seats.
 - d. Olsonite Corp.
2. Description: Toilet seat for water-closet-type fixture.
 - a. Material: Molded, solid plastic with antimicrobial agent.
 - b. Configuration: Open front without cover.
 - c. Size: Elongated.
 - d. Hinge Type: SC, self-sustaining, check.
 - e. Class: Heavy-duty commercial.

- f. Color: White.

2.5 PROTECTIVE SHIELDING GUARDS

- A. Protective Shielding Pipe Covers,:
 - 1. Manufacturers: Subject to compliance with requirements, provide products by one of the following:
 - a. Engineered Brass Co.
 - b. Insul-Tect Products Co.; a Subsidiary of MVG Molded Products.
 - c. McGuire Manufacturing Co., Inc.
 - d. Plumberex Specialty Products Inc.
 - e. TCI Products.
 - f. TRUEBRO, Inc.
 - g. Zurn Plumbing Products Group; Tubular Brass Plumbing Products Operation.
 - 2. Description: Manufactured plastic wraps for covering plumbing fixture hot- and cold-water supplies and trap and drain piping. Comply with Americans with Disabilities Act (ADA) requirements.

2.6 FIXTURE SUPPORTS

- A. Manufacturers: Subject to compliance with requirements, provide products by one of the following:
 - 1. Josam Company.
 - 2. MIFAB Manufacturing Inc.
 - 3. Smith, Jay R. Mfg. Co.
 - 4. Tyler Pipe; Wade Div.
 - 5. Watts Drainage Products Inc.; a div. of Watts Industries, Inc.
 - 6. Zurn Plumbing Products Group; Specification Drainage Operation.
- B. Lavatory Supports,:
 - 1. Description: Type II, lavatory carrier with concealed arms and tie rod for wall-mounting, lavatory-type fixture. Include steel uprights with feet.
 - 2. Accessible-Fixture Support: Include rectangular steel uprights.

2.7 WATER CLOSETS

- A. Water Closets,:
 - 1. Manufacturers: Subject to compliance with requirements, provide products by one of the following:
 - a. As specified on the drawings.
 - 2. Description: Accessible, floor-mounting, floor-outlet, vitreous-china fixture designed for flushometer valve operation.
 - a. Style: Flushometer valve.
 - 1) Bowl Type: Elongated with siphon-jet design. Include bolt caps matching fixture.
 - 2) Height: Accessible.
 - 3) Design Consumption: 1.6 gal./flush.
 - 4) Color: White.

2.8 LAVATORIES

- A. Lavatories,:
 - 1. Manufacturers: Subject to compliance with requirements, provide products by one of the following:
 - a. As specified on the drawings.
 - 2. Description: Accessible, wall-mounting, vitreous-china fixture.
 - a. Type: Ledge back.
 - b. Size: 20 by 18 inches rectangular.
 - c. Faucet Hole Punching: Three holes, 4-inch centers.
 - d. Faucet Hole Location: Top.
 - e. Color: White.
 - f. Drain: Grid.

- g. Drain Piping: NPS 1-1/4 by NPS 1-1/2 chrome-plated, cast-brass P-trap; NPS 1-1/2, 0.045-inch- thick tubular brass waste to wall; and wall escutcheon.
- h. Protective Shielding Guard(s): Required
- i. Fixture Support: Lavatory carrier type.

2.9 COMMERCIAL SINKS

A. Commercial Sinks,;

- 1. Manufacturers: Subject to compliance with requirements, provide products by one of the following:
 - a. As specified on the drawings.
- 2. Description: One or Two-compartment as required by the Drawings, counter-mounting, stainless-steel commercial sink.
 - a. Overall Dimensions: Refer to Drawings
 - b. Metal Thickness: Refer to Drawings.
 - c. Compartment(s):
 - 1) Dimensions: Refer to Drawings
 - 2) Drain: Basket Strainer.
 - d. Faucet(s): Sink.
 - 1) Number Required: One.
 - 2) Mounting: Deck.
 - e. Supplies: NPS 1/2 chrome-plated copper with stops or shutoff valves.
 - f. Drain Piping: NPS 1-1/2 chrome-plated, cast-brass P-trap; 0.045-inch- thick tubular brass waste to wall; and wall escutcheon(s).
 - g. waste.

2.10 EXAMINATION

- A. Examine roughing-in of water supply and sanitary drainage and vent piping systems to verify actual locations of piping connections before plumbing fixture installation.
- B. Examine cabinets, counters, floors, and walls for suitable conditions where fixtures will be installed.
- C. Proceed with installation only after unsatisfactory conditions have been corrected.

2.11 INSTALLATION

- A. Assemble plumbing fixtures, trim, fittings, and other components according to manufacturers' written instructions.
- B. Install off-floor supports, affixed to building substrate, for wall-mounting fixtures.
 - 1. Use carrier supports with waste fitting and seal for back-outlet fixtures.
 - 2. Use carrier supports without waste fitting for fixtures with tubular waste piping.
 - 3. Use chair-type carrier supports with rectangular steel uprights for accessible fixtures.
- C. Install floor-mounting fixtures on closet flanges or other attachments to piping or building substrate.
- D. Install wall-mounting fixtures with tubular waste piping attached to supports.
- E. Install counter-mounting fixtures in and attached to casework.
- F. Install fixtures level and plumb according to roughing-in drawings.
- G. Install water-supply piping with stop on each supply to each fixture to be connected to water distribution piping. Attach supplies to supports or substrate within pipe spaces behind fixtures. Install stops in locations where they can be easily reached for operation.

- H. Install trap and tubular waste piping on drain outlet of each fixture to be directly connected to sanitary drainage system.
- I. Install tubular waste piping on drain outlet of each fixture to be indirectly connected to drainage system.
- J. Install flushometer valves for accessible water closets and urinals with handle mounted on wide side of compartment. Install other actuators in locations that are easy for people with disabilities to reach.
- K. Install toilet seats on water closets.
- L. Install faucet-spout fittings with specified flow rates and patterns in faucet spouts if faucets are not available with required rates and patterns. Include adapters if required.
- M. Install water-supply flow-control fittings with specified flow rates in fixture supplies at stop valves.
- N. Install faucet flow-control fittings with specified flow rates and patterns in faucet spouts if faucets are not available with required rates and patterns. Include adapters if required.
- O. Install shower flow-control fittings with specified maximum flow rates in shower arms.
- P. Install traps on fixture outlets.
 - 1. Exception: Omit trap on fixtures with integral traps.
 - 2. Exception: Omit trap on indirect wastes, unless otherwise indicated.
- Q. Install disposer in outlet of each sink indicated to have disposer. Install switch where indicated or in wall adjacent to sink if location is not indicated.
- R. Install escutcheons at piping wall ceiling penetrations in exposed, finished locations and within cabinets and millwork. Use deep-pattern escutcheons if required to conceal protruding fittings. Escutcheons are specified in Division 22 Section "Common Work Results for Plumbing."
- S. Seal joints between fixtures and walls, floors, and countertops using sanitary-type, one-part, mildew-resistant silicone sealant. Match sealant color to fixture color. Sealants are specified in Division 07 Section "Joint Sealants."

2.12 CONNECTIONS

- A. Piping installation requirements are specified in other Division 22 Sections. Drawings indicate general arrangement of piping, fittings, and specialties.
- B. Connect fixtures with water supplies, stops, and risers, and with traps, soil, waste, and vent piping. Use size fittings required to match fixtures.

2.13 FIELD QUALITY CONTROL

- A. Verify that installed plumbing fixtures are categories and types specified for locations where installed.
- B. Check that plumbing fixtures are complete with trim, faucets, fittings, and other specified components.
- C. Inspect installed plumbing fixtures for damage. Replace damaged fixtures and components.
- D. Test installed fixtures after water systems are pressurized for proper operation. Replace malfunctioning fixtures and components, then retest. Repeat procedure until units operate properly.
- E. Install fresh batteries in sensor-operated mechanisms.

2.14 ADJUSTING

- A. Operate and adjust faucets and controls. Replace damaged and malfunctioning fixtures, fittings, and controls.
- B. Operate and adjust disposers and controls. Replace damaged and malfunctioning units and controls.
- C. Adjust water pressure at faucets and flushometer valves to produce proper flow and stream.
- D. Replace washers and seals of leaking and dripping faucets and stops.

2.15 CLEANING

- A. Clean fixtures, faucets, and other fittings with manufacturers' recommended cleaning methods and materials. Do the following:
 - 1. Remove faucet spouts and strainers, remove sediment and debris, and reinstall strainers and spouts.
 - 2. Remove sediment and debris from drains.
- B. After completing installation of exposed, factory-finished fixtures, faucets, and fittings, inspect exposed finishes and repair damaged finishes.

2.16 PROTECTION

- A. Provide protective covering for installed fixtures and fittings.
- B. Do not allow use of plumbing fixtures for temporary facilities unless approved in writing by Owner.

END OF SECTION 22 4000

SECTION 230500 - COMMON WORK RESULTS FOR HVAC

PART 1 - GENERAL

1.1 RELATED DOCUMENTS

- A. Drawings and general provisions of the Contract, including General and Supplementary Conditions and Division 01 Specification Sections, apply to this Section.

1.2 SUMMARY

- A. This Section includes the following:
 1. Piping materials and installation instructions common to most piping systems.
 2. Transition fittings.
 3. Dielectric fittings.
 4. Mechanical sleeve seals.
 5. Sleeves.
 6. Escutcheons.
 7. Grout.
 8. Equipment installation requirements common to equipment sections.
 9. Painting and finishing.
 10. Concrete bases.
 11. Supports and anchorages.

1.3 DEFINITIONS

- A. Finished Spaces: Spaces other than mechanical and electrical equipment rooms, furred spaces, pipe and duct chases, unheated spaces immediately below roof, spaces above ceilings, unexcavated spaces, crawlspaces, and tunnels.
- B. Exposed, Interior Installations: Exposed to view indoors. Examples include finished occupied spaces and mechanical equipment rooms.
- C. Exposed, Exterior Installations: Exposed to view outdoors or subject to outdoor ambient temperatures and weather conditions. Examples include rooftop locations.
- D. Concealed, Interior Installations: Concealed from view and protected from physical contact by building occupants. Examples include above ceilings and chases.
- E. Concealed, Exterior Installations: Concealed from view and protected from weather conditions and physical contact by building occupants but subject to outdoor ambient temperatures. Examples include installations within unheated shelters.
- F. The following are industry abbreviations for plastic materials:
 1. CPVC: Chlorinated polyvinyl chloride plastic.
 2. PE: Polyethylene plastic.
 3. PVC: Polyvinyl chloride plastic.
- G. The following are industry abbreviations for rubber materials:
 1. EPDM: Ethylene-propylene-diene terpolymer rubber.
 2. NBR: Acrylonitrile-butadiene rubber.

1.4 SUBMITTALS

- A. Product Data: For the following:
 - 1. Transition fittings.
 - 2. Dielectric fittings.
 - 3. Mechanical sleeve seals.
 - 4. Escutcheons.
- B. Welding certificates.

1.5 QUALITY ASSURANCE

- A. Steel Support Welding: Qualify processes and operators according to AWS D1.1, "Structural Welding Code--Steel."
- B. Steel Pipe Welding: Qualify processes and operators according to ASME Boiler and Pressure Vessel Code: Section IX, "Welding and Brazing Qualifications."
 - 1. Comply with provisions in ASME B31 Series, "Code for Pressure Piping."
 - 2. Certify that each welder has passed AWS qualification tests for welding processes involved and that certification is current.
- C. Electrical Characteristics for HVAC Equipment: Equipment of higher electrical characteristics may be furnished provided such proposed equipment is approved in writing and connecting electrical services, circuit breakers, and conduit sizes are appropriately modified. If minimum energy ratings or efficiencies are specified, equipment shall comply with requirements.

1.6 DELIVERY, STORAGE, AND HANDLING

- A. Deliver pipes and tubes with factory-applied end caps. Maintain end caps through shipping, storage, and handling to prevent pipe end damage and to prevent entrance of dirt, debris, and moisture.
- B. Store plastic pipes protected from direct sunlight. Support to prevent sagging and bending.

1.7 COORDINATION

- A. Arrange for pipe spaces, chases, slots, and openings in building structure during progress of construction, to allow for HVAC installations.
- B. Coordinate installation of required supporting devices and set sleeves in poured-in-place concrete and other structural components as they are constructed.
- C. Coordinate requirements for access panels and doors for HVAC items requiring access that are concealed behind finished surfaces. Access panels and doors are specified in Division 08 Section "Access Doors and Frames."

PART 2 - PRODUCTS

2.1 MANUFACTURERS

- A. In other Part 2 articles where subparagraph titles below introduce lists, the following requirements apply for product selection:
 - 1. Manufacturers: Subject to compliance with requirements, provide products by the manufacturers specified.

2.2 PIPE, TUBE, AND FITTINGS

- A. Refer to individual Division 23 piping Sections for pipe, tube, and fitting materials and joining methods.
- B. Pipe Threads: ASME B1.20.1 for factory-threaded pipe and pipe fittings.

2.3 JOINING MATERIALS

- A. Refer to individual Division 23 piping Sections for special joining materials not listed below.
- B. Pipe-Flange Gasket Materials: Suitable for chemical and thermal conditions of piping system contents.
 - 1. ASME B16.21, nonmetallic, flat, asbestos-free, 1/8-inch maximum thickness unless thickness or specific material is indicated.
 - a. Full-Face Type: For flat-face, Class 125, cast-iron and cast-bronze flanges.
 - b. Narrow-Face Type: For raised-face, Class 250, cast-iron and steel flanges.
 - 2. AWWA C110, rubber, flat face, 1/8 inch thick, unless otherwise indicated; and full-face or ring type, unless otherwise indicated.
- C. Flange Bolts and Nuts: ASME B18.2.1, carbon steel, unless otherwise indicated.
- D. Plastic, Pipe-Flange Gasket, Bolts, and Nuts: Type and material recommended by piping system manufacturer, unless otherwise indicated.
- E. Solder Filler Metals: ASTM B 32, lead-free alloys. Include water-flushable flux according to ASTM B 813.
- F. Brazing Filler Metals: AWS A5.8, BCuP Series, copper-phosphorus alloys for general-duty brazing, unless otherwise indicated; and AWS A5.8, BAg1, silver alloy for refrigerant piping, unless otherwise indicated.
- G. Welding Filler Metals: Comply with AWS D10.12 for welding materials appropriate for wall thickness and chemical analysis of steel pipe being welded.
- H. Solvent Cements for Joining Plastic Piping:
 - 1. CPVC Piping: ASTM F 493.
 - 2. PVC Piping: ASTM D 2564. Include primer according to ASTM F 656.
- I. Fiberglass Pipe Adhesive: As furnished or recommended by pipe manufacturer.

2.4 DIELECTRIC FITTINGS

- A. Description: Combination fitting of copper alloy and ferrous materials with threaded, solder-joint, plain, or weld-neck end connections that match piping system materials.
- B. Insulating Material: Suitable for system fluid, pressure, and temperature.
- C. Dielectric Unions: Factory-fabricated, union assembly, for 250-psig minimum working pressure at 180 deg F.
 - 1. Manufacturers:
 - a. Capitol Manufacturing Co.
 - b. Central Plastics Company.
 - c. Eclipse, Inc.
 - d. Epco Sales, Inc.
 - e. Hart Industries, International, Inc.
 - f. Watts Industries, Inc.; Water Products Div.
 - g. Zurn Industries, Inc.; Wilkins Div.
- D. Dielectric Flanges: Factory-fabricated, companion-flange assembly, for 150- or 300-psig minimum working pressure as required to suit system pressures.

1. Manufacturers:
 - a. Capitol Manufacturing Co.
 - b. Central Plastics Company.
 - c. Epco Sales, Inc.
 - d. Watts Industries, Inc.; Water Products Div.

- E. Dielectric-Flange Kits: Companion-flange assembly for field assembly. Include flanges, full-face- or ring-type neoprene or phenolic gasket, phenolic or polyethylene bolt sleeves, phenolic washers, and steel backing washers.
 1. Manufacturers:
 - a. Advance Products & Systems, Inc.
 - b. Calpico, Inc.
 - c. Central Plastics Company.
 - d. Pipeline Seal and Insulator, Inc.
 2. Separate companion flanges and steel bolts and nuts shall have 150- or 300-psig minimum working pressure where required to suit system pressures.

- F. Dielectric Couplings: Galvanized-steel coupling with inert and noncorrosive, thermoplastic lining; threaded ends; and 300-psig minimum working pressure at 225 deg F.
 1. Manufacturers:
 - a. Calpico, Inc.
 - b. Lochinvar Corp.

- G. Dielectric Nipples: Electroplated steel nipple with inert and noncorrosive, thermoplastic lining; plain, threaded, or grooved ends; and 300-psig minimum working pressure at 225 deg F.
 1. Manufacturers:
 - a. Perfection Corp.
 - b. Precision Plumbing Products, Inc.
 - c. Sioux Chief Manufacturing Co., Inc.
 - d. Victaulic Co. of America.

2.5 MECHANICAL SLEEVE SEALS

- A. Description: Modular sealing element unit, designed for field assembly, to fill annular space between pipe and sleeve.
 1. Manufacturers:
 - a. Advance Products & Systems, Inc.
 - b. Calpico, Inc.
 - c. Metraflex Co.
 - d. Pipeline Seal and Insulator, Inc.
 2. Sealing Elements: EPDM interlocking links shaped to fit surface of pipe. Include type and number required for pipe material and size of pipe.
 3. Pressure Plates: Stainless steel. Include two for each sealing element.
 4. Connecting Bolts and Nuts: Stainless steel of length required to secure pressure plates to sealing elements. Include one for each sealing element.

2.6 SLEEVES

- A. Galvanized-Steel Sheet: 0.0239-inch minimum thickness; round tube closed with welded longitudinal joint.
- B. Steel Pipe: ASTM A 53, Type E, Grade B, Schedule 40, galvanized, plain ends.
- C. Cast Iron: Cast or fabricated "wall pipe" equivalent to ductile-iron pressure pipe, with plain ends and integral waterstop, unless otherwise indicated.
- D. Stack Sleeve Fittings: Manufactured, cast-iron sleeve with integral clamping flange. Include clamping ring and bolts and nuts for membrane flashing.
 1. Underdeck Clamp: Clamping ring with set screws.

- E. Molded PVC: Permanent, with nailing flange for attaching to wooden forms.
- F. PVC Pipe: ASTM D 1785, Schedule 40.
- G. Molded PE: Reusable, PE, tapered-cup shaped, and smooth-outer surface with nailing flange for attaching to wooden forms.

2.7 ESCUTCHEONS

- A. Description: Manufactured wall and ceiling escutcheons and floor plates, with an ID to closely fit around pipe, tube, and insulation of insulated piping and an OD that completely covers opening.
- B. One-Piece, Deep-Pattern Type: Deep-drawn, box-shaped brass with polished chrome-plated finish.
- C. One-Piece, Cast-Brass Type: With set screw.
 - 1. Finish: Polished chrome-plated.
- D. Split-Casting, Cast-Brass Type: With concealed hinge and set screw.
 - 1. Finish: Polished chrome-plated.
- E. One-Piece, Stamped-Steel Type: With spring clips and chrome-plated finish.
- F. Split-Plate, Stamped-Steel Type: With concealed hinge, spring clips, and chrome-plated finish.
- G. One-Piece, Floor-Plate Type: Cast-iron floor plate.
- H. Split-Casting, Floor-Plate Type: Cast brass with concealed hinge and set screw.

2.8 GROUT

- A. Description: ASTM C 1107, Grade B, nonshrink and nonmetallic, dry hydraulic-cement grout.
 - 1. Characteristics: Post-hardening, volume-adjusting, nonstaining, noncorrosive, nongaseous, and recommended for interior and exterior applications.
 - 2. Design Mix: 5000-psi, 28-day compressive strength.
 - 3. Packaging: Premixed and factory packaged.

PART 3 - EXECUTION

3.1 PIPING SYSTEMS - COMMON REQUIREMENTS

- A. Install piping according to the following requirements and Division 23 Sections specifying piping systems.
- B. Drawing plans, schematics, and diagrams indicate general location and arrangement of piping systems. Indicated locations and arrangements were used to size pipe and calculate friction loss, expansion, pump sizing, and other design considerations. Install piping as indicated unless deviations to layout are approved on Coordination Drawings.
- C. Install piping in concealed locations, unless otherwise indicated and except in equipment rooms and service areas.
- D. Install piping indicated to be exposed and piping in equipment rooms and service areas at right angles or parallel to building walls. Diagonal runs are prohibited unless specifically indicated otherwise.
- E. Install piping above accessible ceilings to allow sufficient space for ceiling panel removal.

- F. Install piping to permit valve servicing.
- G. Install piping at indicated slopes.
- H. Install piping free of sags and bends.
- I. Install fittings for changes in direction and branch connections.
- J. Install piping to allow application of insulation.
- K. Select system components with pressure rating equal to or greater than system operating pressure.
- L. Install escutcheons for penetrations of walls, ceilings, and floors according to the following:
 - 1. New Piping:
 - a. Piping with Fitting or Sleeve Protruding from Wall: One-piece, deep-pattern type.
 - b. Chrome-Plated Piping: One-piece, cast-brass type with polished chrome-plated finish.
 - c. Insulated Piping: One-piece, stamped-steel type with spring clips.
 - d. Bare Piping at Wall and Floor Penetrations in Finished Spaces: One-piece, cast-brass type with polished chrome-plated finish.
 - e. Bare Piping at Ceiling Penetrations in Finished Spaces: One-piece, cast-brass type with polished chrome-plated finish.
 - f. Bare Piping in Unfinished Service Spaces: One-piece, cast-brass type with polished chrome-plated finish.
 - g. Bare Piping in Equipment Rooms: One-piece, cast-brass type.
 - h. Bare Piping at Floor Penetrations in Equipment Rooms: One-piece, floor-plate type.
- M. Sleeves are not required for core-drilled holes.
- N. Permanent sleeves are not required for holes formed by removable PE sleeves.
- O. Install sleeves for pipes passing through concrete and masonry walls and concrete floor and roof slabs.
- P. Install sleeves for pipes passing through concrete and masonry walls, gypsum-board partitions, and concrete floor and roof slabs.
 - 1. Cut sleeves to length for mounting flush with both surfaces.
 - a. Exception: Extend sleeves installed in floors of mechanical equipment areas or other wet areas 2 inches above finished floor level. Extend cast-iron sleeve fittings below floor slab as required to secure clamping ring if ring is specified.
 - 2. Install sleeves in new walls and slabs as new walls and slabs are constructed.
 - 3. Install sleeves that are large enough to provide 1/4-inch annular clear space between sleeve and pipe or pipe insulation. Use the following sleeve materials:
 - a. Steel Pipe Sleeves: For pipes smaller than NPS 6.
 - b. Steel Sheet Sleeves: For pipes NPS 6 and larger, penetrating gypsum-board partitions.
 - c. Stack Sleeve Fittings: For pipes penetrating floors with membrane waterproofing. Secure flashing between clamping flanges. Install section of cast-iron soil pipe to extend sleeve to 2 inches above finished floor level. Refer to Division 07 Section "Sheet Metal Flashing and Trim" for flashing.
 - 1) Seal space outside of sleeve fittings with grout.
 - 4. Except for underground wall penetrations, seal annular space between sleeve and pipe or pipe insulation, using joint sealants appropriate for size, depth, and location of joint. Refer to Division 07 Section "Joint Sealants" for materials and installation.
- Q. Aboveground, Exterior-Wall Pipe Penetrations: Seal penetrations using sleeves and mechanical sleeve seals. Select sleeve size to allow for 1-inch annular clear space between pipe and sleeve for installing mechanical sleeve seals.
 - 1. Install steel pipe for sleeves smaller than 6 inches in diameter.
 - 2. Install cast-iron "wall pipes" for sleeves 6 inches and larger in diameter.
 - 3. Mechanical Sleeve Seal Installation: Select type and number of sealing elements required for pipe material and size. Position pipe in center of sleeve. Assemble mechanical sleeve seals and install

in annular space between pipe and sleeve. Tighten bolts against pressure plates that cause sealing elements to expand and make watertight seal.

- R. Underground, Exterior-Wall Pipe Penetrations: Install cast-iron "wall pipes" for sleeves. Seal pipe penetrations using mechanical sleeve seals. Select sleeve size to allow for 1-inch annular clear space between pipe and sleeve for installing mechanical sleeve seals.
 - 1. Mechanical Sleeve Seal Installation: Select type and number of sealing elements required for pipe material and size. Position pipe in center of sleeve. Assemble mechanical sleeve seals and install in annular space between pipe and sleeve. Tighten bolts against pressure plates that cause sealing elements to expand and make watertight seal.
- S. Fire-Barrier Penetrations: Maintain indicated fire rating of walls, partitions, ceilings, and floors at pipe penetrations. Seal pipe penetrations with firestop materials. Refer to Division 07 Section "Penetration Firestopping" for materials.
- T. Verify final equipment locations for roughing-in.
- U. Refer to equipment specifications in other Sections of these Specifications for roughing-in requirements.

3.2 PIPING JOINT CONSTRUCTION

- A. Join pipe and fittings according to the following requirements and Division 23 Sections specifying piping systems.
- B. Ream ends of pipes and tubes and remove burrs. Bevel plain ends of steel pipe.
- C. Remove scale, slag, dirt, and debris from inside and outside of pipe and fittings before assembly.
- D. Soldered Joints: Apply ASTM B 813, water-flushable flux, unless otherwise indicated, to tube end. Construct joints according to ASTM B 828 or CDA's "Copper Tube Handbook," using lead-free solder alloy complying with ASTM B 32.
- E. Brazed Joints: Construct joints according to AWS's "Brazing Handbook," "Pipe and Tube" Chapter, using copper-phosphorus brazing filler metal complying with AWS A5.8.
- F. Threaded Joints: Thread pipe with tapered pipe threads according to ASME B1.20.1. Cut threads full and clean using sharp dies. Ream threaded pipe ends to remove burrs and restore full ID. Join pipe fittings and valves as follows:
 - 1. Apply appropriate tape or thread compound to external pipe threads unless dry seal threading is specified.
 - 2. Damaged Threads: Do not use pipe or pipe fittings with threads that are corroded or damaged. Do not use pipe sections that have cracked or open welds.
- G. Welded Joints: Construct joints according to AWS D10.12, using qualified processes and welding operators according to Part 1 "Quality Assurance" Article.
- H. Flanged Joints: Select appropriate gasket material, size, type, and thickness for service application. Install gasket concentrically positioned. Use suitable lubricants on bolt threads.
- I. Plastic Piping Solvent-Cement Joints: Clean and dry joining surfaces. Join pipe and fittings according to the following:
 - 1. Comply with ASTM F 402 for safe-handling practice of cleaners, primers, and solvent cements.
 - 2. CPVC Piping: Join according to ASTM D 2846/D 2846M Appendix.
 - 3. PVC Pressure Piping: Join schedule number ASTM D 1785, PVC pipe and PVC socket fittings according to ASTM D 2672. Join other-than-schedule-number PVC pipe and socket fittings according to ASTM D 2855.
 - 4. PVC Nonpressure Piping: Join according to ASTM D 2855.

- J. Plastic Pressure Piping Gasketed Joints: Join according to ASTM D 3139.
- K. Plastic Nonpressure Piping Gasketed Joints: Join according to ASTM D 3212.
- L. PE Piping Heat-Fusion Joints: Clean and dry joining surfaces by wiping with clean cloth or paper towels. Join according to ASTM D 2657.
 - 1. Plain-End Pipe and Fittings: Use butt fusion.
 - 2. Plain-End Pipe and Socket Fittings: Use socket fusion.
- M. Fiberglass Bonded Joints: Prepare pipe ends and fittings, apply adhesive, and join according to pipe manufacturer's written instructions.

3.3 PIPING CONNECTIONS

- A. Make connections according to the following, unless otherwise indicated:
 - 1. Install unions, in piping NPS 2 and smaller, adjacent to each valve and at final connection to each piece of equipment.
 - 2. Install flanges, in piping NPS 2-1/2 and larger, adjacent to flanged valves and at final connection to each piece of equipment.
 - 3. Dry Piping Systems: Install dielectric unions and flanges to connect piping materials of dissimilar metals.
 - 4. Wet Piping Systems: Install dielectric coupling and nipple fittings to connect piping materials of dissimilar metals.

3.4 EQUIPMENT INSTALLATION - COMMON REQUIREMENTS

- A. Install equipment to allow maximum possible headroom unless specific mounting heights are not indicated.
- B. Install equipment level and plumb, parallel and perpendicular to other building systems and components in exposed interior spaces, unless otherwise indicated.
- C. Install HVAC equipment to facilitate service, maintenance, and repair or replacement of components. Connect equipment for ease of disconnecting, with minimum interference to other installations. Extend grease fittings to accessible locations.
- D. Install equipment to allow right of way for piping installed at required slope.

3.5 PAINTING

- A. Painting of HVAC systems, equipment, and components is specified in Division 09 Sections "Interior Painting" and "Exterior Painting."
- B. Damage and Touchup: Repair marred and damaged factory-painted finishes with materials and procedures to match original factory finish.

3.6 CONCRETE BASES

- A. Concrete Bases: Anchor equipment to concrete base according to equipment manufacturer's written instructions and according to seismic codes at Project.
 - 1. Construct concrete bases of dimensions indicated, but not less than 4 inches larger in both directions than supported unit.
 - 2. Install dowel rods to connect concrete base to concrete floor. Unless otherwise indicated, install dowel rods on 18-inch centers around the full perimeter of the base.
 - 3. Install epoxy-coated anchor bolts for supported equipment that extend through concrete base, and anchor into structural concrete floor.

4. Place and secure anchorage devices. Use supported equipment manufacturer's setting drawings, templates, diagrams, instructions, and directions furnished with items to be embedded.
5. Install anchor bolts to elevations required for proper attachment to supported equipment.
6. Install anchor bolts according to anchor-bolt manufacturer's written instructions.
7. Use 3000-psi, 28-day compressive-strength concrete and reinforcement as specified in Division 03 Section "Cast-in-Place Concrete."

3.7 ERECTION OF METAL SUPPORTS AND ANCHORAGES

- A. Refer to Division 05 Section "Metal Fabrications" for structural steel.
- B. Cut, fit, and place miscellaneous metal supports accurately in location, alignment, and elevation to support and anchor HVAC materials and equipment.
- C. Field Welding: Comply with AWS D1.1.

3.8 ERECTION OF WOOD SUPPORTS AND ANCHORAGES

- A. Cut, fit, and place wood grounds, nailers, blocking, and anchorages to support, and anchor HVAC materials and equipment.
- B. Select fastener sizes that will not penetrate members if opposite side will be exposed to view or will receive finish materials. Tighten connections between members. Install fasteners without splitting wood members.
- C. Attach to substrates as required to support applied loads.

3.9 GROUTING

- A. Mix and install grout for HVAC equipment base bearing surfaces, pump and other equipment base plates, and anchors.
- B. Clean surfaces that will come into contact with grout.
- C. Provide forms as required for placement of grout.
- D. Avoid air entrapment during placement of grout.
- E. Place grout, completely filling equipment bases.
- F. Place grout on concrete bases and provide smooth bearing surface for equipment.
- G. Place grout around anchors.
- H. Cure placed grout.

END OF SECTION 230500

SECTION 230529 - HANGERS AND SUPPORTS FOR HVAC PIPING AND EQUIPMENT

PART 1 - GENERAL

1.1 RELATED DOCUMENTS

- A. Drawings and general provisions of the Contract, including General and Supplementary Conditions and Division 01 Specification Sections, apply to this Section.

1.2 SUMMARY

- A. Section Includes:
 - 1. Metal pipe hangers and supports.
 - 2. Trapeze pipe hangers.
 - 3. Metal framing systems.
 - 4. Thermal-hanger shield inserts.
 - 5. Fastener systems.
 - 6. Pipe stands.
 - 7. Equipment supports.
- B. Related Sections:
 - 1. Division 05 Section "Metal Fabrications" for structural-steel shapes and plates for trapeze hangers for pipe and equipment supports.
 - 2. Division 23 Section(s) "Metal Ducts" for duct hangers and supports.

1.3 DEFINITIONS

- A. MSS: Manufacturers Standardization Society of The Valve and Fittings Industry Inc.

1.4 PERFORMANCE REQUIREMENTS

- A. Delegated Design: Design trapeze pipe hangers and equipment supports, including comprehensive engineering analysis by a qualified professional engineer, using performance requirements and design criteria indicated.
- B. Structural Performance: Hangers and supports for HVAC piping and equipment shall withstand the effects of gravity loads and stresses within limits and under conditions indicated according to ASCE/SEI 7.
 - 1. Design supports for multiple pipes, including pipe stands, capable of supporting combined weight of supported systems, system contents, and test water.
 - 2. Design equipment supports capable of supporting combined operating weight of supported equipment and connected systems and components.

1.5 SUBMITTALS

- A. Product Data: For each type of product indicated.
- B. Shop Drawings: Show fabrication and installation details and include calculations for the following; include Product Data for components:
 - 1. Trapeze pipe hangers.
 - 2. Metal framing systems.
 - 3. Fiberglass strut systems.
 - 4. Pipe stands.

5. Equipment supports.
 - C. Delegated-Design Submittal: For trapeze hangers indicated to comply with performance requirements and design criteria, including analysis data signed and sealed by the qualified professional engineer responsible for their preparation.
 1. Detail fabrication and assembly of trapeze hangers.
 2. Design Calculations: Calculate requirements for designing trapeze hangers.
 - D. Welding certificates.
- 1.6 QUALITY ASSURANCE
- A. Structural Steel Welding Qualifications: Qualify procedures and personnel according to AWS D1.1/D1.1M, "Structural Welding Code - Steel."
 - B. Pipe Welding Qualifications: Qualify procedures and operators according to ASME Boiler and Pressure Vessel Code.

PART 2 - PRODUCTS

2.1 METAL PIPE HANGERS AND SUPPORTS

- A. Carbon-Steel Pipe Hangers and Supports:
 1. Description: MSS SP-58, Types 1 through 58, factory-fabricated components.
 2. Galvanized Metallic Coatings: Pregalvanized or hot dipped.
 3. Nonmetallic Coatings: Plastic coating, jacket, or liner.
 4. Padded Hangers: Hanger with fiberglass or other pipe insulation pad or cushion to support bearing surface of piping.
 5. Hanger Rods: Continuous-thread rod, nuts, and washer made of carbon steel.
- B. Stainless-Steel Pipe Hangers and Supports:
 1. Description: MSS SP-58, Types 1 through 58, factory-fabricated components.
 2. Padded Hangers: Hanger with fiberglass or other pipe insulation pad or cushion to support bearing surface of piping.
 3. Hanger Rods: Continuous-thread rod, nuts, and washer made of Insert material.
- C. Copper Pipe Hangers:
 1. Description: MSS SP-58, Types 1 through 58, copper-coated-steel, factory-fabricated components.
 2. Hanger Rods: Continuous-thread rod, nuts, and washer made of copper-coated steel.

2.2 TRAPEZE PIPE HANGERS

- A. Description: MSS SP-69, Type 59, shop- or field-fabricated pipe-support assembly made from structural carbon-steel shapes with MSS SP-58 carbon-steel hanger rods, nuts, saddles, and U-bolts.

2.3 METAL FRAMING SYSTEMS

- A. MFMA Manufacturer Metal Framing Systems:
 1. Manufacturers: Subject to compliance with requirements, provide products by one of the following:
 - a. Allied Tube & Conduit.
 - b. Cooper B-Line, Inc.
 - c. Flex-Strut Inc.
 - d. GS Metals Corp.
 - e. Thomas & Betts Corporation.

- f. Unistrut Corporation; Tyco International, Ltd.
- g. Wesanco, Inc.
- 2. Description: Shop- or field-fabricated pipe-support assembly for supporting multiple parallel pipes.
- 3. Standard: MFMA-4.
- 4. Channels: Continuous slotted steel channel with inturred lips.
- 5. Channel Nuts: Formed or stamped steel nuts or other devices designed to fit into channel slot and, when tightened, prevent slipping along channel.
- 6. Hanger Rods: Continuous-thread rod, nuts, and washer made of carbon steel.
- 7. Metallic Coating: Electroplated zinc.
- 8. Paint Coating: Epoxy.
- 9. Plastic Coating: Epoxy.

2.4 THERMAL-HANGER SHIELD INSERTS

- A. Manufacturers: Subject to compliance with requirements, provide products by one of the following:
 - 1. Carpenter & Paterson, Inc.
 - 2. Clement Support Services.
 - 3. ERICO International Corporation.
 - 4. National Pipe Hanger Corporation.
 - 5. PHS Industries, Inc.
 - 6. Pipe Shields, Inc.; a subsidiary of Piping Technology & Products, Inc.
 - 7. Piping Technology & Products, Inc.
 - 8. Rilco Manufacturing Co., Inc.
 - 9. Value Engineered Products, Inc.
- B. Insulation-Insert Material for Cold Piping: ASTM C 552, Type II cellular glass with 100-psig minimum compressive strength and vapor barrier.
- C. Insulation-Insert Material for Hot Piping: ASTM C 552, Type II cellular glass with 100-psig minimum compressive strength.
- D. For Trapeze or Clamped Systems: Insert and shield shall cover entire circumference of pipe.
- E. For Clevis or Band Hangers: Insert and shield shall cover lower 180 degrees of pipe.
- F. Insert Length: Extend 2 inches beyond sheet metal shield for piping operating below ambient air temperature.

2.5 FASTENER SYSTEMS

- A. Powder-Actuated Fasteners: Threaded-steel stud, for use in hardened portland cement concrete with pull-out, tension, and shear capacities appropriate for supported loads and building materials where used.
- B. Mechanical-Expansion Anchors: Insert-wedge-type, stainless- steel anchors, for use in hardened portland cement concrete; with pull-out, tension, and shear capacities appropriate for supported loads and building materials where used.

2.6 PIPE STANDS

- A. General Requirements for Pipe Stands: Shop- or field-fabricated assemblies made of manufactured corrosion-resistant components to support roof-mounted piping.
- B. Compact Pipe Stand: One-piece plastic unit with integral-rod roller, pipe clamps, or V-shaped cradle to support pipe, for roof installation without membrane penetration.

- C. Low-Type, Single-Pipe Stand: One-piece stainless-steel base unit with plastic roller, for roof installation without membrane penetration.
- D. High-Type, Single-Pipe Stand:
 - 1. Description: Assembly of base, vertical and horizontal members, and pipe support, for roof installation without membrane penetration.
 - 2. Base: Stainless steel.
 - 3. Vertical Members: Two or more cadmium-plated-steel or stainless-steel, continuous-thread rods.
 - 4. Horizontal Member: Cadmium-plated-steel or stainless-steel rod with plastic or stainless-steel, roller-type pipe support.
- E. High-Type, Multiple-Pipe Stand:
 - 1. Description: Assembly of bases, vertical and horizontal members, and pipe supports, for roof installation without membrane penetration.
 - 2. Bases: One or more; plastic.
 - 3. Vertical Members: Two or more protective-coated-steel channels.
 - 4. Horizontal Member: Protective-coated-steel channel.
 - 5. Pipe Supports: Galvanized-steel, clevis-type pipe hangers.
- F. Curb-Mounted-Type Pipe Stands: Shop- or field-fabricated pipe supports made from structural-steel shapes, continuous-thread rods, and rollers, for mounting on permanent stationary roof curb.

2.7 EQUIPMENT SUPPORTS

- A. Description: Welded, shop- or field-fabricated equipment support made from structural carbon-steel shapes.

2.8 MISCELLANEOUS MATERIALS

- A. Structural Steel: ASTM A 36/A 36M, carbon-steel plates, shapes, and bars; black and galvanized.
- B. Grout: ASTM C 1107, factory-mixed and -packaged, dry, hydraulic-cement, nonshrink and nonmetallic grout; suitable for interior and exterior applications.
 - 1. Properties: Nonstaining, noncorrosive, and nongaseous.
 - 2. Design Mix: 5000-psi, 28-day compressive strength.

PART 3 - EXECUTION

3.1 HANGER AND SUPPORT INSTALLATION

- A. Metal Pipe-Hanger Installation: Comply with MSS SP-69 and MSS SP-89. Install hangers, supports, clamps, and attachments as required to properly support piping from the building structure.
- B. Metal Trapeze Pipe-Hanger Installation: Comply with MSS SP-69 and MSS SP-89. Arrange for grouping of parallel runs of horizontal piping, and support together on field-fabricated trapeze pipe hangers.
 - 1. Pipes of Various Sizes: Support together and space trapezes for smallest pipe size or install intermediate supports for smaller diameter pipes as specified for individual pipe hangers.
 - 2. Field fabricate from ASTM A 36/A 36M, carbon-steel shapes selected for loads being supported. Weld steel according to AWS D1.1/D1.1M.
- C. Metal Framing System Installation: Arrange for grouping of parallel runs of piping, and support together on field-assembled metal framing systems.
- D. Thermal-Hanger Shield Installation: Install in pipe hanger or shield for insulated piping.

- E. Fastener System Installation:
 - 1. Install powder-actuated fasteners for use in lightweight concrete or concrete slabs less than 4 inches thick in concrete after concrete is placed and completely cured. Use operators that are licensed by powder-actuated tool manufacturer. Install fasteners according to powder-actuated tool manufacturer's operating manual.
 - 2. Install mechanical-expansion anchors in concrete after concrete is placed and completely cured. Install fasteners according to manufacturer's written instructions.

- F. Pipe Stand Installation:
 - 1. Pipe Stand Types except Curb-Mounted Type: Assemble components and mount on smooth roof surface. Do not penetrate roof membrane.
 - 2. Curb-Mounted-Type Pipe Stands: Assemble components or fabricate pipe stand and mount on permanent, stationary roof curb. See Division 07 Section "Roof Accessories" for curbs.

- G. Install hangers and supports complete with necessary attachments, inserts, bolts, rods, nuts, washers, and other accessories.

- H. Equipment Support Installation: Fabricate from welded-structural-steel shapes.

- I. Install hangers and supports to allow controlled thermal and seismic movement of piping systems, to permit freedom of movement between pipe anchors, and to facilitate action of expansion joints, expansion loops, expansion bends, and similar units.

- J. Install lateral bracing with pipe hangers and supports to prevent swaying.

- K. Install building attachments within concrete slabs or attach to structural steel. Install additional attachments at concentrated loads, including valves, flanges, and strainers, NPS 2-1/2 and larger and at changes in direction of piping. Install concrete inserts before concrete is placed; fasten inserts to forms and install reinforcing bars through openings at top of inserts.

- L. Load Distribution: Install hangers and supports so that piping live and dead loads and stresses from movement will not be transmitted to connected equipment.

- M. Pipe Slopes: Install hangers and supports to provide indicated pipe slopes and to not exceed maximum pipe deflections allowed by ASME B31.9 for building services piping.

- N. Insulated Piping:
 - 1. Attach clamps and spacers to piping.
 - a. Piping Operating above Ambient Air Temperature: Clamp may project through insulation.
 - b. Piping Operating below Ambient Air Temperature: Use thermal-hanger shield insert with clamp sized to match OD of insert.
 - c. Do not exceed pipe stress limits allowed by ASME B31.9 for building services piping.
 - 2. Install MSS SP-58, Type 39, protection saddles if insulation without vapor barrier is indicated. Fill interior voids with insulation that matches adjoining insulation.
 - a. Option: Thermal-hanger shield inserts may be used. Include steel weight-distribution plate for pipe NPS 4 and larger if pipe is installed on rollers.
 - 3. Install MSS SP-58, Type 40, protective shields on cold piping with vapor barrier. Shields shall span an arc of 180 degrees.
 - a. Option: Thermal-hanger shield inserts may be used. Include steel weight-distribution plate for pipe NPS 4 and larger if pipe is installed on rollers.
 - 4. Shield Dimensions for Pipe: Not less than the following:
 - a. NPS 1/4 to NPS 3-1/2: 12 inches long and 0.048 inch thick.
 - b. NPS 4: 12 inches long and 0.06 inch thick.
 - c. NPS 5 and NPS 6: 18 inches long and 0.06 inch thick.
 - d. NPS 8 to NPS 14: 24 inches long and 0.075 inch thick.
 - e. NPS 16 to NPS 24: 24 inches long and 0.105 inch thick.
 - 5. Pipes NPS 8 and Larger: Include wood or reinforced calcium-silicate-insulation inserts of length at least as long as protective shield.
 - 6. Thermal-Hanger Shields: Install with insulation same thickness as piping insulation.

3.2 EQUIPMENT SUPPORTS

- A. Fabricate structural-steel stands to suspend equipment from structure overhead or to support equipment above floor.
- B. Grouting: Place grout under supports for equipment and make bearing surface smooth.
- C. Provide lateral bracing, to prevent swaying, for equipment supports.

3.3 METAL FABRICATIONS

- A. Cut, drill, and fit miscellaneous metal fabrications for trapeze pipe hangers and equipment supports.
- B. Fit exposed connections together to form hairline joints. Field weld connections that cannot be shop welded because of shipping size limitations.
- C. Field Welding: Comply with AWS D1.1/D1.1M procedures for shielded, metal arc welding; appearance and quality of welds; and methods used in correcting welding work; and with the following:
 - 1. Use materials and methods that minimize distortion and develop strength and corrosion resistance of base metals.
 - 2. Obtain fusion without undercut or overlap.
 - 3. Remove welding flux immediately.
 - 4. Finish welds at exposed connections so no roughness shows after finishing and so contours of welded surfaces match adjacent contours.

3.4 ADJUSTING

- A. Hanger Adjustments: Adjust hangers to distribute loads equally on attachments and to achieve indicated slope of pipe.
- B. Trim excess length of continuous-thread hanger and support rods to 1-1/2 inches.

3.5 PAINTING

- A. Touchup: Clean field welds and abraded areas of shop paint. Paint exposed areas immediately after erecting hangers and supports. Use same materials as used for shop painting. Comply with SSPC-PA 1 requirements for touching up field-painted surfaces.
 - 1. Apply paint by brush or spray to provide a minimum dry film thickness of 2.0 mils.
- B. Touchup: Cleaning and touchup painting of field welds, bolted connections, and abraded areas of shop paint on miscellaneous metal are specified in Division 09 painting Sections.
- C. Galvanized Surfaces: Clean welds, bolted connections, and abraded areas and apply galvanizing-repair paint to comply with ASTM A 780.

3.6 HANGER AND SUPPORT SCHEDULE

- A. Specific hanger and support requirements are in Sections specifying piping systems and equipment.
- B. Comply with MSS SP-69 for pipe-hanger selections and applications that are not specified in piping system Sections.
- C. Use hangers and supports with galvanized metallic coatings for piping and equipment that will not have field-applied finish.

- D. Use nonmetallic coatings on attachments for electrolytic protection where attachments are in direct contact with copper tubing.
- E. Use carbon-steel pipe hangers and supports, metal trapeze pipe hangers and metal framing systems and attachments for general service applications.
- F. Use stainless-steel pipe hangers and stainless-steel attachments for hostile environment applications.
- G. Use copper-plated pipe hangers and copper attachments for copper piping and tubing.
- H. Use padded hangers for piping that is subject to scratching.
- I. Use thermal-hanger shield inserts for insulated piping and tubing.
- J. Horizontal-Piping Hangers and Supports: Unless otherwise indicated and except as specified in piping system Sections, install the following types:
 - 1. Adjustable, Steel Clevis Hangers (MSS Type 1): For suspension of noninsulated or insulated, stationary pipes NPS 1/2 to NPS 30.
 - 2. Yoke-Type Pipe Clamps (MSS Type 2): For suspension of up to 1050 deg F, pipes NPS 4 to NPS 24, requiring up to 4 inches of insulation.
 - 3. Carbon- or Alloy-Steel, Double-Bolt Pipe Clamps (MSS Type 3): For suspension of pipes NPS 3/4 to NPS 36, requiring clamp flexibility and up to 4 inches of insulation.
 - 4. Steel Pipe Clamps (MSS Type 4): For suspension of cold and hot pipes NPS 1/2 to NPS 24 if little or no insulation is required.
 - 5. Pipe Hangers (MSS Type 5): For suspension of pipes NPS 1/2 to NPS 4, to allow off-center closure for hanger installation before pipe erection.
 - 6. Adjustable, Swivel Split- or Solid-Ring Hangers (MSS Type 6): For suspension of noninsulated, stationary pipes NPS 3/4 to NPS 8.
 - 7. Adjustable, Steel Band Hangers (MSS Type 7): For suspension of noninsulated, stationary pipes NPS 1/2 to NPS 8.
 - 8. Adjustable Band Hangers (MSS Type 9): For suspension of noninsulated, stationary pipes NPS 1/2 to NPS 8.
 - 9. Adjustable, Swivel-Ring Band Hangers (MSS Type 10): For suspension of noninsulated, stationary pipes NPS 1/2 to NPS 8.
 - 10. Split Pipe Ring with or without Turnbuckle Hangers (MSS Type 11): For suspension of noninsulated, stationary pipes NPS 3/8 to NPS 8.
 - 11. Extension Hinged or Two-Bolt Split Pipe Clamps (MSS Type 12): For suspension of noninsulated, stationary pipes NPS 3/8 to NPS 3.
 - 12. U-Bolts (MSS Type 24): For support of heavy pipes NPS 1/2 to NPS 30.
 - 13. Clips (MSS Type 26): For support of insulated pipes not subject to expansion or contraction.
 - 14. Pipe Saddle Supports (MSS Type 36): For support of pipes NPS 4 to NPS 36, with steel-pipe base stanchion support and cast-iron floor flange or carbon-steel plate.
 - 15. Pipe Stanchion Saddles (MSS Type 37): For support of pipes NPS 4 to NPS 36, with steel-pipe base stanchion support and cast-iron floor flange or carbon-steel plate, and with U-bolt to retain pipe.
 - 16. Adjustable Pipe Saddle Supports (MSS Type 38): For stanchion-type support for pipes NPS 2-1/2 to NPS 36 if vertical adjustment is required, with steel-pipe base stanchion support and cast-iron floor flange.
 - 17. Single-Pipe Rolls (MSS Type 41): For suspension of pipes NPS 1 to NPS 30, from two rods if longitudinal movement caused by expansion and contraction might occur.
 - 18. Adjustable Roller Hangers (MSS Type 43): For suspension of pipes NPS 2-1/2 to NPS 24, from single rod if horizontal movement caused by expansion and contraction might occur.
 - 19. Complete Pipe Rolls (MSS Type 44): For support of pipes NPS 2 to NPS 42 if longitudinal movement caused by expansion and contraction might occur but vertical adjustment is not necessary.
 - 20. Pipe Roll and Plate Units (MSS Type 45): For support of pipes NPS 2 to NPS 24 if small horizontal movement caused by expansion and contraction might occur and vertical adjustment is not necessary.
 - 21. Adjustable Pipe Roll and Base Units (MSS Type 46): For support of pipes NPS 2 to NPS 30 if vertical and lateral adjustment during installation might be required in addition to expansion and contraction.

- K. Vertical-Piping Clamps: Unless otherwise indicated and except as specified in piping system Sections, install the following types:
1. Extension Pipe or Riser Clamps (MSS Type 8): For support of pipe risers NPS 3/4 to NPS 24.
 2. Carbon- or Alloy-Steel Riser Clamps (MSS Type 42): For support of pipe risers NPS 3/4 to NPS 24 if longer ends are required for riser clamps.
- L. Hanger-Rod Attachments: Unless otherwise indicated and except as specified in piping system Sections, install the following types:
1. Steel Turnbuckles (MSS Type 13): For adjustment up to 6 inches for heavy loads.
 2. Steel Clevises (MSS Type 14): For 120 to 450 deg F piping installations.
 3. Swivel Turnbuckles (MSS Type 15): For use with MSS Type 11, split pipe rings.
 4. Malleable-Iron Sockets (MSS Type 16): For attaching hanger rods to various types of building attachments.
 5. Steel Weldless Eye Nuts (MSS Type 17): For 120 to 450 deg F piping installations.
- M. Building Attachments: Unless otherwise indicated and except as specified in piping system Sections, install the following types:
1. Steel or Malleable Concrete Inserts (MSS Type 18): For upper attachment to suspend pipe hangers from concrete ceiling.
 2. Top-Beam C-Clamps (MSS Type 19): For use under roof installations with bar-joint construction, to attach to top flange of structural shape.
 3. Side-Beam or Channel Clamps (MSS Type 20): For attaching to bottom flange of beams, channels, or angles.
 4. Center-Beam Clamps (MSS Type 21): For attaching to center of bottom flange of beams.
 5. Welded Beam Attachments (MSS Type 22): For attaching to bottom of beams if loads are considerable and rod sizes are large.
 6. C-Clamps (MSS Type 23): For structural shapes.
 7. Top-Beam Clamps (MSS Type 25): For top of beams if hanger rod is required tangent to flange edge.
 8. Side-Beam Clamps (MSS Type 27): For bottom of steel I-beams.
 9. Steel-Beam Clamps with Eye Nuts (MSS Type 28): For attaching to bottom of steel I-beams for heavy loads.
 10. Linked-Steel Clamps with Eye Nuts (MSS Type 29): For attaching to bottom of steel I-beams for heavy loads, with link extensions.
 11. Malleable-Beam Clamps with Extension Pieces (MSS Type 30): For attaching to structural steel.
 12. Welded-Steel Brackets: For support of pipes from below or for suspending from above by using clip and rod. Use one of the following for indicated loads:
 - a. Light (MSS Type 31): 750 lb.
 - b. Medium (MSS Type 32): 1500 lb.
 - c. Heavy (MSS Type 33): 3000 lb.
 13. Side-Beam Brackets (MSS Type 34): For sides of steel or wooden beams.
 14. Plate Lugs (MSS Type 57): For attaching to steel beams if flexibility at beam is required.
 15. Horizontal Travelers (MSS Type 58): For supporting piping systems subject to linear horizontal movement where headroom is limited.
- N. Saddles and Shields: Unless otherwise indicated and except as specified in piping system Sections, install the following types:
1. Steel-Pipe-Covering Protection Saddles (MSS Type 39): To fill interior voids with insulation that matches adjoining insulation.
 2. Protection Shields (MSS Type 40): Of length recommended in writing by manufacturer to prevent crushing insulation.
 3. Thermal-Hanger Shield Inserts: For supporting insulated pipe.
- O. Spring Hangers and Supports: Unless otherwise indicated and except as specified in piping system Sections, install the following types:
1. Restraint-Control Devices (MSS Type 47): Where indicated to control piping movement.
 2. Spring Cushions (MSS Type 48): For light loads if vertical movement does not exceed 1-1/4 inches.
 3. Spring-Cushion Roll Hangers (MSS Type 49): For equipping Type 41, roll hanger with springs.
 4. Spring Sway Braces (MSS Type 50): To retard sway, shock, vibration, or thermal expansion in piping systems.

5. Variable-Spring Hangers (MSS Type 51): Preset to indicated load and limit variability factor to 25 percent to allow expansion and contraction of piping system from hanger.
 6. Variable-Spring Base Supports (MSS Type 52): Preset to indicated load and limit variability factor to 25 percent to allow expansion and contraction of piping system from base support.
 7. Variable-Spring Trapeze Hangers (MSS Type 53): Preset to indicated load and limit variability factor to 25 percent to allow expansion and contraction of piping system from trapeze support.
 8. Constant Supports: For critical piping stress and if necessary to avoid transfer of stress from one support to another support, critical terminal, or connected equipment. Include auxiliary stops for erection, hydrostatic test, and load-adjustment capability. These supports include the following types:
 - a. Horizontal (MSS Type 54): Mounted horizontally.
 - b. Vertical (MSS Type 55): Mounted vertically.
 - c. Trapeze (MSS Type 56): Two vertical-type supports and one trapeze member.
- P. Comply with MSS SP-69 for trapeze pipe-hanger selections and applications that are not specified in piping system Sections.
- Q. Comply with MFMA-103 for metal framing system selections and applications that are not specified in piping system Sections.
- R. Use powder-actuated fasteners or mechanical-expansion anchors instead of building attachments where required in concrete construction.
- END OF SECTION 230529

SECTION 230553 - IDENTIFICATION FOR HVAC PIPING AND EQUIPMENT

PART 1 - GENERAL

1.1 RELATED DOCUMENTS

- A. Drawings and general provisions of the Contract, including General and Supplementary Conditions and Division 01 Specification Sections, apply to this Section.

1.2 SUMMARY

- A. Section Includes:
 - 1. Equipment labels.
 - 2. Warning signs and labels.
 - 3. Pipe labels.
 - 4. Valve tags.
 - 5. Warning tags.

1.3 SUBMITTALS

- A. Product Data: For each type of product indicated.
- B. Samples: For color, letter style, and graphic representation required for each identification material and device.
- C. Equipment Label Schedule: Include a listing of all equipment to be labeled with the proposed content for each label.
- D. Valve numbering scheme.
- E. Valve Schedules: For each piping system to include in maintenance manuals.

1.4 COORDINATION

- A. Coordinate installation of identifying devices with completion of covering and painting of surfaces where devices are to be applied.
- B. Coordinate installation of identifying devices with locations of access panels and doors.
- C. Install identifying devices before installing acoustical ceilings and similar concealment.

PART 2 - PRODUCTS

2.1 EQUIPMENT LABELS

- A. Metal Labels for Equipment:
 - 1. Material and Thickness: Aluminum, 0.032-inch minimum thickness, and having predrilled or stamped holes for attachment hardware.
 - 2. Minimum Label Size: Length and width vary for required label content, but not less than 2-1/2 by 3/4 inch.

3. Minimum Letter Size: 1/4 inch for name of units if viewing distance is less than 24 inches, 1/2 inch for viewing distances up to 72 inches, and proportionately larger lettering for greater viewing distances. Include secondary lettering two-thirds to three-fourths the size of principal lettering.
 4. Fasteners: Stainless-steel self-tapping screws.
 5. Adhesive: Contact-type permanent adhesive, compatible with label and with substrate.
- B. Plastic Labels for Equipment:
1. Material and Thickness: Multilayer, multicolor, plastic labels for mechanical engraving, 1/8 inch thick, and having predrilled holes for attachment hardware.
 2. Letter Color: White.
 3. Background Color: Black.
 4. Maximum Temperature: Able to withstand temperatures up to 160 deg F.
 5. Minimum Label Size: Length and width vary for required label content, but not less than 2-1/2 by 3/4 inch.
 6. Minimum Letter Size: 1/4 inch for name of units if viewing distance is less than 24 inches, 1/2 inch for viewing distances up to 72 inches, and proportionately larger lettering for greater viewing distances. Include secondary lettering two-thirds to three-fourths the size of principal lettering.
 7. Fasteners: Stainless-steel self-tapping screws.
 8. Adhesive: Contact-type permanent adhesive, compatible with label and with substrate.
- C. Label Content: Include equipment's Drawing designation or unique equipment number, Drawing numbers where equipment is indicated (plans, details, and schedules), plus the Specification Section number and title where equipment is specified.
- D. Equipment Label Schedule: For each item of equipment to be labeled, on 8-1/2-by-11-inch bond paper. Tabulate equipment identification number and identify Drawing numbers where equipment is indicated (plans, details, and schedules), plus the Specification Section number and title where equipment is specified. Equipment schedule shall be included in operation and maintenance data.

2.2 WARNING SIGNS AND LABELS

- A. Material and Thickness: Multilayer, multicolor, plastic labels for mechanical engraving, 1/8 inch thick, and having predrilled holes for attachment hardware.
- B. Letter Color: White.
- C. Background Color: Black.
- D. Maximum Temperature: Able to withstand temperatures up to 160 deg F.
- E. Minimum Label Size: Length and width vary for required label content, but not less than 2-1/2 by 3/4 inch.
- F. Minimum Letter Size: 1/4 inch for name of units if viewing distance is less than 24 inches, 1/2 inch for viewing distances up to 72 inches, and proportionately larger lettering for greater viewing distances. Include secondary lettering two-thirds to three-fourths the size of principal lettering.
- G. Fasteners: Stainless-steel self-tapping screws.
- H. Adhesive: Contact-type permanent adhesive, compatible with label and with substrate.
- I. Label Content: Include caution and warning information, plus emergency notification instructions.

2.3 PIPE LABELS

- A. General Requirements for Manufactured Pipe Labels: Preprinted, color-coded, with lettering indicating service, and showing flow direction.

- B. Pretensioned Pipe Labels: Precoiled, semirigid plastic formed to cover full circumference of pipe and to attach to pipe without fasteners or adhesive.
- C. Pipe Label Contents: Include identification of piping service using same designations or abbreviations as used on Drawings, pipe size, and an arrow indicating flow direction.
 - 1. Flow-Direction Arrows: Integral with piping system service lettering to accommodate both directions, or as separate unit on each pipe label to indicate flow direction.
 - 2. Lettering Size: At least 1-1/2 inches high.

2.4 VALVE TAGS

- A. Valve Tags: Stamped or engraved with 1/4-inch letters for piping system abbreviation and 1/2-inch numbers.
 - 1. Tag Material: Brass, 0.032-inch minimum thickness, and having predrilled or stamped holes for attachment hardware.
 - 2. Fasteners: Brass beaded chain.
- B. Valve Schedules: For each piping system, on 8-1/2-by-11-inch bond paper. Tabulate valve number, piping system, system abbreviation (as shown on valve tag), location of valve (room or space), normal-operating position (open, closed, or modulating), and variations for identification. Mark valves for emergency shutoff and similar special uses.
 - 1. Valve-tag schedule shall be included in operation and maintenance data.

2.5 WARNING TAGS

- A. Warning Tags: Preprinted or partially preprinted, accident-prevention tags, of plasticized card stock with matte finish suitable for writing.
 - 1. Size: Approximately 4 by 7 inches.
 - 2. Fasteners: Brass grommet and wire.
 - 3. Nomenclature: Large-size primary caption such as "DANGER," "CAUTION," or "DO NOT OPERATE."
 - 4. Color: Yellow background with black lettering.

PART 3 - EXECUTION

3.1 PREPARATION

- A. Clean piping and equipment surfaces of substances that could impair bond of identification devices, including dirt, oil, grease, release agents, and incompatible primers, paints, and encapsulants.

3.2 EQUIPMENT LABEL INSTALLATION

- A. Install or permanently fasten labels on each major item of mechanical equipment.
- B. Locate equipment labels where accessible and visible.

3.3 PIPE LABEL INSTALLATION

- A. Locate pipe labels where piping is exposed or above accessible ceilings in finished spaces; machine rooms; accessible maintenance spaces such as shafts, tunnels, and plenums; and exterior exposed locations as follows:
 - 1. Near each valve and control device.

2. Near each branch connection, excluding short takeoffs for fixtures and terminal units. Where flow pattern is not obvious, mark each pipe at branch.
3. Near penetrations through walls, floors, ceilings, and inaccessible enclosures.
4. At access doors, manholes, and similar access points that permit view of concealed piping.
5. Near major equipment items and other points of origination and termination.
6. Spaced at maximum intervals of 40 feet along each run. Reduce intervals to 20 feet in areas of congested piping and equipment.
7. On piping above removable acoustical ceilings. Omit intermediately spaced labels.

B. Pipe Label Color Schedule:

1. Chilled-Water Piping:
 - a. Background Color: Green.
 - b. Letter Color: White.
2. Heating Water Piping:
 - a. Background Color: Yellow.
 - b. Letter Color: Black.
3. Refrigerant Piping:
 - a. Background Color: Green.
 - b. Letter Color: White.

3.4 VALVE-TAG INSTALLATION

- A. Install tags on valves and control devices in piping systems, except check valves; valves within factory-fabricated equipment units; shutoff valves; faucets; convenience and lawn-watering hose connections; and HVAC terminal devices and similar roughing-in connections of end-use fixtures and units. List tagged valves in a valve schedule.
- B. Valve-Tag Application Schedule: Tag valves according to size, shape, and color scheme and with captions similar to those indicated in the following subparagraphs:
 1. Valve-Tag Size and Shape:
 - a. Chilled Water: 2 inches, round.
 - b. Hot Water: 2 inches, round.
 - c. Gas: 2 inches, round.
 2. Valve-Tag Color:
 - a. All Services: Natural.
 3. Letter Color:
 - a. All Services: Black.

3.5 WARNING-TAG INSTALLATION

- A. Write required message on, and attach warning tags to, equipment and other items where required.

END OF SECTION 230553

SECTION 230593 - TESTING, ADJUSTING, AND BALANCING FOR HVAC

PART 1 - GENERAL

1.1 RELATED DOCUMENTS

- A. Drawings and general provisions of the Contract, including General and Supplementary Conditions and Division 01 Specification Sections, apply to this Section.

1.2 SUMMARY

- A. Section Includes:
 - 1. Balancing Air Systems:
 - a. Constant-volume air systems.

1.3 DEFINITIONS

- A. AABC: Associated Air Balance Council.
- B. NEBB: National Environmental Balancing Bureau.
- C. TAB: Testing, adjusting, and balancing.
- D. TABB: Testing, Adjusting, and Balancing Bureau.
- E. TAB Specialist: An entity engaged to perform TAB Work.

1.4 SUBMITTALS

- A. Qualification Data: Within 30 days of Contractor's Notice to Proceed, submit documentation that the TAB contractor and this Project's TAB team members meet the qualifications specified in "Quality Assurance" Article.
- B. Contract Documents Examination Report: Within 45 days of Contractor's Notice to Proceed, submit the Contract Documents review report as specified in Part 3.
- C. Strategies and Procedures Plan: Within 60 days of Contractor's Notice to Proceed, submit TAB strategies and step-by-step procedures as specified in "Preparation" Article.
- D. Certified TAB reports.
- E. Sample report forms.
- F. Instrument calibration reports, to include the following:
 - 1. Instrument type and make.
 - 2. Serial number.
 - 3. Application.
 - 4. Dates of use.
 - 5. Dates of calibration.

1.5 QUALITY ASSURANCE

- A. TAB Contractor Qualifications: Engage a TAB entity certified by AABC or NEBB.
 - 1. TAB Field Supervisor: Employee of the TAB contractor and certified by AABC.
 - 2. TAB Technician: Employee of the TAB contractor and who is certified by AABC as a TAB technician.
- B. TAB Conference: Meet with Commissioning Authority on approval of the TAB strategies and procedures plan to develop a mutual understanding of the details. Require the participation of the TAB field supervisor and technicians. Provide seven days' advance notice of scheduled meeting time and location.
 - 1. Agenda Items:
 - a. The Contract Documents examination report.
 - b. The TAB plan.
 - c. Coordination and cooperation of trades and subcontractors.
 - d. Coordination of documentation and communication flow.
- C. Certify TAB field data reports and perform the following:
 - 1. Review field data reports to validate accuracy of data and to prepare certified TAB reports.
 - 2. Certify that the TAB team complied with the approved TAB plan and the procedures specified and referenced in this Specification.
- D. TAB Report Forms: Use standard TAB contractor's forms approved by Engineer.
- E. Instrumentation Type, Quantity, Accuracy, and Calibration: As described in ASHRAE 111, Section 5, "Instrumentation."

1.6 PROJECT CONDITIONS

- A. Partial Owner Occupancy: Owner may occupy completed areas of building before Substantial Completion. Cooperate with Owner during TAB operations to minimize conflicts with Owner's operations.

1.7 COORDINATION

- A. Notice: Provide seven days' advance notice for each test. Include scheduled test dates and times.
- B. Perform TAB after leakage and pressure tests on air and water distribution systems have been satisfactorily completed.

PART 2 - PRODUCTS (Not Applicable)

PART 3 - EXECUTION

3.1 TAB SPECIALISTS

- A. Subject to compliance with requirements, engage the following:
 - 1. AABC or NEBB certified firm. Air balance firms shall be contracted directly with the mechanical contractor. 3rd party/brokers are not acceptable.

3.2 EXAMINATION

- A. Examine the Contract Documents to become familiar with Project requirements and to discover conditions in systems' designs that may preclude proper TAB of systems and equipment.
- B. Examine systems for installed balancing devices, such as test ports, gage cocks, thermometer wells, flow-control devices, balancing valves and fittings, and manual volume dampers. Verify that locations of these balancing devices are accessible.
- C. Examine the approved submittals for HVAC systems and equipment.
- D. Examine design data including HVAC system descriptions, statements of design assumptions for environmental conditions and systems' output, and statements of philosophies and assumptions about HVAC system and equipment controls.
- E. Examine ceiling plenums and underfloor air plenums used for supply, return, or relief air to verify that they meet the leakage class of connected ducts as specified in Division 23 Section "Metal Ducts" and are properly separated from adjacent areas. Verify that penetrations in plenum walls are sealed and fire-stopped if required.
- F. Examine equipment performance data including fan and pump curves.
 - 1. Relate performance data to Project conditions and requirements, including system effects that can create undesired or unpredicted conditions that cause reduced capacities in all or part of a system.
 - 2. Calculate system-effect factors to reduce performance ratings of HVAC equipment when installed under conditions different from the conditions used to rate equipment performance. To calculate system effects for air systems, use tables and charts found in AMCA 201, "Fans and Systems," or in SMACNA's "HVAC Systems - Duct Design." Compare results with the design data and installed conditions.
- G. Examine system and equipment installations and verify that field quality-control testing, cleaning, and adjusting specified in individual Sections have been performed.
- H. Examine test reports specified in individual system and equipment Sections.
- I. Examine HVAC equipment and filters and verify that bearings are greased, belts are aligned and tight, and equipment with functioning controls is ready for operation.
- J. Examine terminal units, such as variable-air-volume boxes, and verify that they are accessible and their controls are connected and functioning.
- K. Examine strainers. Verify that startup screens are replaced by permanent screens with indicated perforations.
- L. Examine three-way valves for proper installation for their intended function of diverting or mixing fluid flows.
- M. Examine heat-transfer coils for correct piping connections and for clean and straight fins.
- N. Examine system pumps to ensure absence of entrained air in the suction piping.
- O. Examine operating safety interlocks and controls on HVAC equipment.
- P. Report deficiencies discovered before and during performance of TAB procedures. Observe and record system reactions to changes in conditions. Record default set points if different from indicated values.

3.3 PREPARATION

- A. Prepare a TAB plan that includes strategies and step-by-step procedures.
- B. Complete system-readiness checks and prepare reports. Verify the following:
 - 1. Permanent electrical-power wiring is complete.
 - 2. Hydronic systems are filled, clean, and free of air.
 - 3. Automatic temperature-control systems are operational.
 - 4. Equipment and duct access doors are securely closed.
 - 5. Balance, smoke, and fire dampers are open.
 - 6. Isolating and balancing valves are open and control valves are operational.
 - 7. Ceilings are installed in critical areas where air-pattern adjustments are required and access to balancing devices is provided.
 - 8. Windows and doors can be closed so indicated conditions for system operations can be met.

3.4 GENERAL PROCEDURES FOR TESTING AND BALANCING

- A. Perform testing and balancing procedures on each system according to the procedures contained in AABC's "National Standards for Total System Balance" and in this Section.
 - 1. Comply with requirements in ASHRAE 62.1-2004, Section 7.2.2, "Air Balancing."
- B. Cut insulation, ducts, pipes, and equipment cabinets for installation of test probes to the minimum extent necessary for TAB procedures.
 - 1. After testing and balancing, patch probe holes in ducts with same material and thickness as used to construct ducts.
 - 2. After testing and balancing, install test ports and duct access doors that comply with requirements in Division 23 Section "Air Duct Accessories."
 - 3. Install and join new insulation that matches removed materials. Restore insulation, coverings, vapor barrier, and finish according to Division 23 Section "HVAC Insulation."
- C. Mark equipment and balancing devices, including damper-control positions, valve position indicators, fan-speed-control levers, and similar controls and devices, with paint or other suitable, permanent identification material to show final settings.
- D. Take and report testing and balancing measurements in inch-pound (IP) units.

3.5 GENERAL PROCEDURES FOR BALANCING AIR SYSTEMS

- A. Prepare test reports for both fans and outlets. Obtain manufacturer's outlet factors and recommended testing procedures. Crosscheck the summation of required outlet volumes with required fan volumes.
- B. Prepare schematic diagrams of systems' "as-built" duct layouts.
- C. For variable-air-volume systems, develop a plan to simulate diversity.
- D. Determine the best locations in main and branch ducts for accurate duct-airflow measurements.
- E. Check airflow patterns from the outdoor-air louvers and dampers and the return- and exhaust-air dampers through the supply-fan discharge and mixing dampers.
- F. Locate start-stop and disconnect switches, electrical interlocks, and motor starters.
- G. Verify that motor starters are equipped with properly sized thermal protection.
- H. Check dampers for proper position to achieve desired airflow path.

- I. Check for airflow blockages.
- J. Check condensate drains for proper connections and functioning.
- K. Check for proper sealing of air-handling-unit components.
- L. Verify that air duct system is sealed as specified in Division 23 Section "Metal Ducts."

3.6 PROCEDURES FOR CONSTANT-VOLUME AIR SYSTEMS

- A. Adjust fans to deliver total indicated airflows within the maximum allowable fan speed listed by fan manufacturer.
 - 1. Measure total airflow.
 - a. Where sufficient space in ducts is unavailable for Pitot-tube traverse measurements, measure airflow at terminal outlets and inlets and calculate the total airflow.
 - 2. Measure fan static pressures as follows to determine actual static pressure:
 - a. Measure outlet static pressure as far downstream from the fan as practical and upstream from restrictions in ducts such as elbows and transitions.
 - b. Measure static pressure directly at the fan outlet or through the flexible connection.
 - c. Measure inlet static pressure of single-inlet fans in the inlet duct as near the fan as possible, upstream from the flexible connection, and downstream from duct restrictions.
 - d. Measure inlet static pressure of double-inlet fans through the wall of the plenum that houses the fan.
 - 3. Measure static pressure across each component that makes up an air-handling unit, rooftop unit, and other air-handling and -treating equipment.
 - a. Report the cleanliness status of filters and the time static pressures are measured.
 - 4. Measure static pressures entering and leaving other devices, such as sound traps, heat-recovery equipment, and air washers, under final balanced conditions.
 - 5. Review Record Documents to determine variations in design static pressures versus actual static pressures. Calculate actual system-effect factors. Recommend adjustments to accommodate actual conditions.
 - 6. Obtain approval from Engineer for adjustment of fan speed higher or lower than indicated speed. Comply with requirements in Division 23 Sections for air-handling units for adjustment of fans, belts, and pulley sizes to achieve indicated air-handling-unit performance.
 - 7. Do not make fan-speed adjustments that result in motor overload. Consult equipment manufacturers about fan-speed safety factors. Modulate dampers and measure fan-motor amperage to ensure that no overload will occur. Measure amperage in full-cooling, full-heating, economizer, and any other operating mode to determine the maximum required brake horsepower.
- B. Adjust volume dampers for main duct, submain ducts, and major branch ducts to indicated airflows within specified tolerances.
 - 1. Measure airflow of submain and branch ducts.
 - a. Where sufficient space in submain and branch ducts is unavailable for Pitot-tube traverse measurements, measure airflow at terminal outlets and inlets and calculate the total airflow for that zone.
 - 2. Measure static pressure at a point downstream from the balancing damper, and adjust volume dampers until the proper static pressure is achieved.
 - 3. Remeasure each submain and branch duct after all have been adjusted. Continue to adjust submain and branch ducts to indicated airflows within specified tolerances.
- C. Measure air outlets and inlets without making adjustments.
 - 1. Measure terminal outlets using a direct-reading hood or outlet manufacturer's written instructions and calculating factors.
- D. Adjust air outlets and inlets for each space to indicated airflows within specified tolerances of indicated values. Make adjustments using branch volume dampers rather than extractors and the dampers at air terminals.

1. Adjust each outlet in same room or space to within specified tolerances of indicated quantities without generating noise levels above the limitations prescribed by the Contract Documents.
2. Adjust patterns of adjustable outlets for proper distribution without drafts.

3.7 PROCEDURES FOR MOTORS

- A. Motors, 1/2 HP and Larger: Test at final balanced conditions and record the following data:
 1. Manufacturer's name, model number, and serial number.
 2. Motor horsepower rating.
 3. Motor rpm.
 4. Efficiency rating.
 5. Nameplate and measured voltage, each phase.
 6. Nameplate and measured amperage, each phase.
 7. Starter thermal-protection-element rating.
- B. Motors Driven by Variable-Frequency Controllers: Test for proper operation at speeds varying from minimum to maximum. Test the manual bypass of the controller to prove proper operation. Record observations including name of controller manufacturer, model number, serial number, and nameplate data.

3.8 PROCEDURES FOR CONDENSING UNITS

- A. Verify proper rotation of fans.
- B. Measure entering- and leaving-air temperatures.
- C. Record compressor data.

3.9 PROCEDURES FOR HEAT-TRANSFER COILS

- A. Measure, adjust, and record the following data for each water coil:
 1. Entering- and leaving-water temperature.
 2. Water flow rate.
 3. Water pressure drop.
 4. Dry-bulb temperature of entering and leaving air.
 5. Wet-bulb temperature of entering and leaving air for cooling coils.
 6. Airflow.
 7. Air pressure drop.
- B. Measure, adjust, and record the following data for each electric heating coil:
 1. Nameplate data.
 2. Airflow.
 3. Entering- and leaving-air temperature at full load.
 4. Voltage and amperage input of each phase at full load and at each incremental stage.
 5. Calculated kilowatt at full load.
 6. Fuse or circuit-breaker rating for overload protection.
- C. Measure, adjust, and record the following data for each steam coil:
 1. Dry-bulb temperature of entering and leaving air.
 2. Airflow.
 3. Air pressure drop.
 4. Inlet steam pressure.
- D. Measure, adjust, and record the following data for each refrigerant coil:
 1. Dry-bulb temperature of entering and leaving air.

2. Wet-bulb temperature of entering and leaving air.
3. Airflow.
4. Air pressure drop.
5. Refrigerant suction pressure and temperature.

3.10 TOLERANCES

- A. Set HVAC system's air flow rates and water flow rates within the following tolerances:
1. Supply, Return, and Exhaust Fans and Equipment with Fans: Plus or minus 5 percent.
 2. Air Outlets and Inlets: Plus or minus 5 percent.
 3. Heating-Water Flow Rate: Plus or minus 5 percent.
 4. Cooling-Water Flow Rate: Plus or minus 5 percent.

3.11 REPORTING

- A. Initial Construction-Phase Report: Based on examination of the Contract Documents as specified in "Examination" Article, prepare a report on the adequacy of design for systems' balancing devices. Recommend changes and additions to systems' balancing devices to facilitate proper performance measuring and balancing. Recommend changes and additions to HVAC systems and general construction to allow access for performance measuring and balancing devices.
- B. Status Reports: Prepare biweekly progress reports to describe completed procedures, procedures in progress, and scheduled procedures. Include a list of deficiencies and problems found in systems being tested and balanced. Prepare a separate report for each system and each building floor for systems serving multiple floors.

3.12 FINAL REPORT

- A. General: Prepare a certified written report; tabulate and divide the report into separate sections for tested systems and balanced systems.
1. Include a certification sheet at the front of the report's binder, signed and sealed by the certified testing and balancing engineer.
 2. Include a list of instruments used for procedures, along with proof of calibration.
- B. Final Report Contents: In addition to certified field-report data, include the following:
1. Pump curves.
 2. Fan curves.
 3. Manufacturers' test data.
 4. Field test reports prepared by system and equipment installers.
 5. Other information relative to equipment performance; do not include Shop Drawings and product data.
- C. General Report Data: In addition to form titles and entries, include the following data:
1. Title page.
 2. Name and address of the TAB contractor.
 3. Project name.
 4. Project location.
 5. Architect's name and address.
 6. Engineer's name and address.
 7. Contractor's name and address.
 8. Report date.
 9. Signature of TAB supervisor who certifies the report.
 10. Table of Contents with the total number of pages defined for each section of the report. Number each page in the report.
 11. Summary of contents including the following:
 - a. Indicated versus final performance.

- b. Notable characteristics of systems.
 - c. Description of system operation sequence if it varies from the Contract Documents.
 12. Nomenclature sheets for each item of equipment.
 13. Data for terminal units, including manufacturer's name, type, size, and fittings.
 14. Notes to explain why certain final data in the body of reports vary from indicated values.
 15. Test conditions for fans and pump performance forms including the following:
 - a. Settings for outdoor-, return-, and exhaust-air dampers.
 - b. Conditions of filters.
 - c. Cooling coil, wet- and dry-bulb conditions.
 - d. Face and bypass damper settings at coils.
 - e. Fan drive settings including settings and percentage of maximum pitch diameter.
 - f. Inlet vane settings for variable-air-volume systems.
 - g. Settings for supply-air, static-pressure controller.
 - h. Other system operating conditions that affect performance.
- D. System Diagrams: Include schematic layouts of air and hydronic distribution systems. Present each system with single-line diagram and include the following:
 1. Quantities of outdoor, supply, return, and exhaust airflows.
 2. Water and steam flow rates.
 3. Duct, outlet, and inlet sizes.
 4. Pipe and valve sizes and locations.
 5. Terminal units.
 6. Balancing stations.
 7. Position of balancing devices.
- E. Air-Handling-Unit Test Reports: For air-handling units with coils, include the following:
 1. Unit Data:
 - a. Unit identification.
 - b. Location.
 - c. Make and type.
 - d. Model number and unit size.
 - e. Manufacturer's serial number.
 - f. Unit arrangement and class.
 - g. Discharge arrangement.
 - h. Sheave make, size in inches, and bore.
 - i. Center-to-center dimensions of sheave, and amount of adjustments in inches.
 - j. Number, make, and size of belts.
 - k. Number, type, and size of filters.
 2. Motor Data:
 - a. Motor make, and frame type and size.
 - b. Horsepower and rpm.
 - c. Volts, phase, and hertz.
 - d. Full-load amperage and service factor.
 - e. Sheave make, size in inches, and bore.
 - f. Center-to-center dimensions of sheave, and amount of adjustments in inches.
 3. Test Data (Indicated and Actual Values):
 - a. Total air flow rate in cfm.
 - b. Total system static pressure in inches wg.
 - c. Fan rpm.
 - d. Discharge static pressure in inches wg.
 - e. Filter static-pressure differential in inches wg.
 - f. Preheat-coil static-pressure differential in inches wg.
 - g. Cooling-coil static-pressure differential in inches wg.
 - h. Heating-coil static-pressure differential in inches wg.
 - i. Outdoor airflow in cfm.
 - j. Return airflow in cfm.
 - k. Outdoor-air damper position.
 - l. Return-air damper position.
 - m. Vortex damper position.

- F. Apparatus-Coil Test Reports:
1. Coil Data:
 - a. System identification.
 - b. Location.
 - c. Coil type.
 - d. Number of rows.
 - e. Fin spacing in fins per inch o.c.
 - f. Make and model number.
 - g. Face area in sq. ft..
 - h. Tube size in NPS.
 - i. Tube and fin materials.
 - j. Circuiting arrangement.
 2. Test Data (Indicated and Actual Values):
 - a. Air flow rate in cfm.
 - b. Average face velocity in fpm.
 - c. Air pressure drop in inches wg.
 - d. Outdoor-air, wet- and dry-bulb temperatures in deg F.
 - e. Return-air, wet- and dry-bulb temperatures in deg F.
 - f. Entering-air, wet- and dry-bulb temperatures in deg F.
 - g. Leaving-air, wet- and dry-bulb temperatures in deg F.
 - h. Water flow rate in gpm.
 - i. Water pressure differential in feet of head or psig.
 - j. Entering-water temperature in deg F.
 - k. Leaving-water temperature in deg F.
 - l. Refrigerant expansion valve and refrigerant types.
 - m. Refrigerant suction pressure in psig.
 - n. Refrigerant suction temperature in deg F.
 - o. Inlet steam pressure in psig.
- G. Electric-Coil Test Reports: For electric furnaces, duct coils, and electric coils installed in central-station air-handling units, include the following:
1. Unit Data:
 - a. System identification.
 - b. Location.
 - c. Coil identification.
 - d. Capacity in Btu/h.
 - e. Number of stages.
 - f. Connected volts, phase, and hertz.
 - g. Rated amperage.
 - h. Air flow rate in cfm.
 - i. Face area in sq. ft..
 - j. Minimum face velocity in fpm.
 2. Test Data (Indicated and Actual Values):
 - a. Heat output in Btu/h.
 - b. Air flow rate in cfm.
 - c. Air velocity in fpm.
 - d. Entering-air temperature in deg F.
 - e. Leaving-air temperature in deg F.
 - f. Voltage at each connection.
 - g. Amperage for each phase.
- H. Fan Test Reports: For supply, return, and exhaust fans, include the following:
1. Fan Data:
 - a. System identification.
 - b. Location.
 - c. Make and type.
 - d. Model number and size.
 - e. Manufacturer's serial number.
 - f. Arrangement and class.
 - g. Sheave make, size in inches, and bore.

- h. Center-to-center dimensions of sheave, and amount of adjustments in inches.
 2. Motor Data:
 - a. Motor make, and frame type and size.
 - b. Horsepower and rpm.
 - c. Volts, phase, and hertz.
 - d. Full-load amperage and service factor.
 - e. Sheave make, size in inches, and bore.
 - f. Center-to-center dimensions of sheave, and amount of adjustments in inches.
 - g. Number, make, and size of belts.
 3. Test Data (Indicated and Actual Values):
 - a. Total airflow rate in cfm.
 - b. Total system static pressure in inches wg.
 - c. Fan rpm.
 - d. Discharge static pressure in inches wg.
 - e. Suction static pressure in inches wg.
- I. Round, Flat-Oval, and Rectangular Duct Traverse Reports: Include a diagram with a grid representing the duct cross-section and record the following:
 1. Report Data:
 - a. System and air-handling-unit number.
 - b. Location and zone.
 - c. Traverse air temperature in deg F.
 - d. Duct static pressure in inches wg.
 - e. Duct size in inches.
 - f. Duct area in sq. ft..
 - g. Indicated air flow rate in cfm.
 - h. Indicated velocity in fpm.
 - i. Actual air flow rate in cfm.
 - j. Actual average velocity in fpm.
 - k. Barometric pressure in psig.
- J. Instrument Calibration Reports:
 1. Report Data:
 - a. Instrument type and make.
 - b. Serial number.
 - c. Application.
 - d. Dates of use.
 - e. Dates of calibration.

3.13 INSPECTIONS

- A. Initial Inspection:
 1. After testing and balancing are complete, operate each system and randomly check measurements to verify that the system is operating according to the final test and balance readings documented in the final report.
 2. Check the following for each system:
 - a. Measure airflow of at least 10 percent of air outlets.
 - b. Measure water flow of at least 5 percent of terminals.
 - c. Measure room temperature at each thermostat/temperature sensor. Compare the reading to the set point.
 - d. Verify that balancing devices are marked with final balance position.
 - e. Note deviations from the Contract Documents in the final report.
- B. Final Inspection:
 1. After initial inspection is complete and documentation by random checks verifies that testing and balancing are complete and accurately documented in the final report, request that a final inspection be made by Engineer and Commissioning Authority..
 2. The TAB contractor's test and balance engineer shall conduct the inspection in the presence of Engineer and Commissioning Authority.

3. Engineer & Commissioning Authority shall randomly select measurements, documented in the final report, to be rechecked. Rechecking shall be limited to either 10 percent of the total measurements recorded or the extent of measurements that can be accomplished in a normal 8-hour business day.
 4. If rechecks yield measurements that differ from the measurements documented in the final report by more than the tolerances allowed, the measurements shall be noted as "FAILED."
 5. If the number of "FAILED" measurements is greater than 10 percent of the total measurements checked during the final inspection, the testing and balancing shall be considered incomplete and shall be rejected.
- C. TAB Work will be considered defective if it does not pass final inspections. If TAB Work fails, proceed as follows:
1. Recheck all measurements and make adjustments. Revise the final report and balancing device settings to include all changes; resubmit the final report and request a second final inspection.
 2. If the second final inspection also fails, Owner may contract the services of another TAB contractor to complete TAB Work according to the Contract Documents and deduct the cost of the services from the original TAB contractor's final payment.
- D. Prepare test and inspection reports.

3.14 ADDITIONAL TESTS

- A. Within 90 days of completing TAB, perform additional TAB to verify that balanced conditions are being maintained throughout and to correct unusual conditions.
- B. Seasonal Periods: If initial TAB procedures were not performed during near-peak summer and winter conditions, perform additional TAB during near-peak summer and winter conditions.

END OF SECTION 230593

SECTION 230700 - HVAC INSULATION

PART 1 - GENERAL

1.1 RELATED DOCUMENTS

- A. Drawings and general provisions of the Contract, including General and Supplementary Conditions and Division 01 Specification Sections, apply to this Section.

1.2 SUMMARY

- A. Section Includes:
 - 1. Insulation Materials:
 - a. Flexible elastomeric.
 - b. Mineral fiber.
 - 2. Insulating cements.
 - 3. Adhesives.
 - 4. Mastics.
 - 5. Lagging adhesives.
 - 6. Sealants.
 - 7. Factory-applied jackets.
 - 8. Field-applied fabric-reinforcing mesh.
 - 9. Field-applied cloths.
 - 10. Field-applied jackets.
 - 11. Tapes.
 - 12. Securements.
 - 13. Corner angles.
- B. Related Sections:
 - 1. Division 22 Section "Plumbing Insulation."
 - 2. Division 23 Section "Metal Ducts" for duct liners.

1.3 SUBMITTALS

- A. Product Data: For each type of product indicated. Include thermal conductivity, thickness, and jackets (both factory and field applied, if any).
- B. Shop Drawings:
 - 1. Detail application of protective shields, saddles, and inserts at hangers for each type of insulation and hanger.
 - 2. Detail attachment and covering of heat tracing inside insulation.
 - 3. Detail insulation application at pipe expansion joints for each type of insulation.
 - 4. Detail insulation application at elbows, fittings, flanges, valves, and specialties for each type of insulation.
 - 5. Detail removable insulation at piping specialties, equipment connections, and access panels.
 - 6. Detail application of field-applied jackets.
 - 7. Detail application at linkages of control devices.
 - 8. Detail field application for each equipment type.
- C. Samples: For each type of insulation and jacket indicated. Identify each Sample, describing product and intended use.
 - 1. Sample Sizes:
 - a. Preformed Pipe Insulation Materials: 12 inches long by NPS 2.
 - b. Sheet Form Insulation Materials: 12 inches square.
 - c. Jacket Materials for Pipe: 12 inches long by NPS 2.

- d. Sheet Jacket Materials: 12 inches square.
- e. Manufacturer's Color Charts: For products where color is specified, show the full range of colors available for each type of finish material.

D. Qualification Data: For qualified Installer.

E. Material Test Reports: From a qualified testing agency acceptable to authorities having jurisdiction indicating, interpreting, and certifying test results for compliance of insulation materials, sealers, attachments, cements, and jackets, with requirements indicated. Include dates of tests and test methods employed.

F. Field quality-control reports.

1.4 QUALITY ASSURANCE

A. Installer Qualifications: Skilled mechanics who have successfully completed an apprenticeship program or another craft training program certified by the Department of Labor, Bureau of Apprenticeship and Training.

B. Fire-Test-Response Characteristics: Insulation and related materials shall have fire-test-response characteristics indicated, as determined by testing identical products per ASTM E 84, by a testing and inspecting agency acceptable to authorities having jurisdiction. Factory label insulation and jacket materials and adhesive, mastic, tapes, and cement material containers, with appropriate markings of applicable testing and inspecting agency.

- 1. Insulation Installed Indoors: Flame-spread index of 25 or less, and smoke-developed index of 50 or less.
- 2. Insulation Installed Outdoors: Flame-spread index of 75 or less, and smoke-developed index of 150 or less.

1.5 DELIVERY, STORAGE, AND HANDLING

A. Packaging: Insulation material containers shall be marked by manufacturer with appropriate ASTM standard designation, type and grade, and maximum use temperature.

1.6 COORDINATION

A. Coordinate size and location of supports, hangers, and insulation shields specified in Division 23 Section "Hangers and Supports for HVAC Piping and Equipment."

B. Coordinate clearance requirements with piping Installer for piping insulation application, duct Installer for duct insulation application, and equipment Installer for equipment insulation application. Before preparing piping and ductwork Shop Drawings, establish and maintain clearance requirements for installation of insulation and field-applied jackets and finishes and for space required for maintenance.

C. Coordinate installation and testing of heat tracing.

1.7 SCHEDULING

A. Schedule insulation application after pressure testing systems and, where required, after installing and testing heat tracing. Insulation application may begin on segments that have satisfactory test results.

B. Complete installation and concealment of plastic materials as rapidly as possible in each area of construction.

PART 2 - PRODUCTS

2.1 INSULATION MATERIALS

- A. Comply with requirements in Part 3 schedule articles for where insulating materials shall be applied.
- B. Products shall not contain asbestos, lead, mercury, or mercury compounds.
- C. Products that come in contact with stainless steel shall have a leachable chloride content of less than 50 ppm when tested according to ASTM C 871.
- D. Insulation materials for use on austenitic stainless steel shall be qualified as acceptable according to ASTM C 795.
- E. Foam insulation materials shall not use CFC or HCFC blowing agents in the manufacturing process.
- F. Cellular Glass: Inorganic, incombustible, foamed or cellulated glass with annealed, rigid, hermetically sealed cells. Factory-applied jacket requirements are specified in "Factory-Applied Jackets" Article.
 - 1. Products: Subject to compliance with requirements, provide one of the following:
 - a. Cell-U-Foam Corporation; Ultra-CUF.
 - b. Pittsburgh Corning Corporation; Foamglas Super K.
 - 2. Block Insulation: ASTM C 552, Type I.
 - 3. Special-Shaped Insulation: ASTM C 552, Type III.
 - 4. Board Insulation: ASTM C 552, Type IV.
 - 5. Preformed Pipe Insulation without Jacket: Comply with ASTM C 552, Type II, Class 1.
 - 6. Preformed Pipe Insulation with Factory-Applied ASJ-SSL: Comply with ASTM C 552, Type II, Class 2.
 - 7. Factory fabricate shapes according to ASTM C 450 and ASTM C 585.
- G. Flexible Elastomeric: Closed-cell, sponge- or expanded-rubber materials. Comply with ASTM C 534, Type I for tubular materials and Type II for sheet materials.
 - 1. Products: Subject to compliance with requirements, provide one of the following:
 - a. Armacell LLC; AP Armaflex.
 - b. RBX Corporation; Insul-Sheet 1800 and Insul-Tube 180.
- H. Mineral-Fiber Blanket Insulation: Mineral or glass fibers bonded with a thermosetting resin. Comply with ASTM C 553, Type II and ASTM C 1290, Type III with factory-applied FSK jacket. Factory-applied jacket requirements are specified in "Factory-Applied Jackets" Article.
 - 1. Products: Subject to compliance with requirements, provide one of the following:
 - a. CertainTeed Corp.; Duct Wrap.
 - b. Johns Manville; Microlite.
 - c. Knauf Insulation; Duct Wrap.
 - d. Manson Insulation Inc.; Alley Wrap.
 - e. Owens Corning; All-Service Duct Wrap.
- I. Mineral-Fiber Board Insulation: Mineral or glass fibers bonded with a thermosetting resin. Comply with ASTM C 612, Type IA or Type IB. For duct and plenum applications, provide insulation with factory-applied FSK jacket. For equipment applications, provide insulation with factory-applied FSK jacket. Factory-applied jacket requirements are specified in "Factory-Applied Jackets" Article.
 - 1. Products: Subject to compliance with requirements, provide one of the following:
 - a. CertainTeed Corp.; Commercial Board.
 - b. Fibrex Insulations Inc.; FBX.
 - c. Johns Manville; 800 Series Spin-Glas.
 - d. Knauf Insulation; Insulation Board.
 - e. Manson Insulation Inc.; AK Board.
 - f. Owens Corning; Fiberglas 700 Series.
- J. Mineral-Fiber, Preformed Pipe Insulation:
 - 1. Products: Subject to compliance with requirements, provide one of the following:

- a. Fibrex Insulations Inc.; Coreplus 1200.
 - b. Johns Manville; Micro-Lok.
 - c. Knauf Insulation; 1000 Pipe Insulation.
 - d. Manson Insulation Inc.; Alley-K.
 - e. Owens Corning; Fiberglas Pipe Insulation.
2. Type I, 850 deg F Materials: Mineral or glass fibers bonded with a thermosetting resin. Comply with ASTM C 547, Type I, Grade A, with factory-applied ASJ-SSL. Factory-applied jacket requirements are specified in "Factory-Applied Jackets" Article.
- K. Mineral-Fiber, Pipe and Tank Insulation: Mineral or glass fibers bonded with a thermosetting resin. Semirigid board material with factory-applied FSK jacket complying with ASTM C 1393, Type II or Type IIIA Category 2, or with properties similar to ASTM C 612, Type IB. Nominal density is 2.5 lb/cu. ft. or more. Thermal conductivity (k-value) at 100 deg F is 0.29 Btu x in./h x sq. ft. x deg F or less. Factory-applied jacket requirements are specified in "Factory-Applied Jackets" Article.
1. Products: Subject to compliance with requirements, provide one of the following:
 - a. CertainTeed Corp.; CrimpWrap.
 - b. Johns Manville; MicroFlex.
 - c. Knauf Insulation; Pipe and Tank Insulation.
 - d. Manson Insulation Inc.; AK Flex.
 - e. Owens Corning; Fiberglas Pipe and Tank Insulation.

2.2 INSULATING CEMENTS

- A. Mineral-Fiber Insulating Cement: Comply with ASTM C 195.
1. Products: Subject to compliance with requirements, provide one of the following:
 - a. Insulco, Division of MFS, Inc.; Triple I.
 - b. P. K. Insulation Mfg. Co., Inc.; Super-Stik.
- B. Expanded or Exfoliated Vermiculite Insulating Cement: Comply with ASTM C 196.
1. Products: Subject to compliance with requirements, provide one of the following:
 - a. P. K. Insulation Mfg. Co., Inc.; Thermal-V-Kote.
- C. Mineral-Fiber, Hydraulic-Setting Insulating and Finishing Cement: Comply with ASTM C 449/C 449M.
1. Products: Subject to compliance with requirements, provide one of the following:
 - a. Insulco, Division of MFS, Inc.; SmoothKote.
 - b. P. K. Insulation Mfg. Co., Inc.; PK No. 127, and Quik-Cote.
 - c. Rock Wool Manufacturing Company; Delta One Shot.

2.3 ADHESIVES

- A. Materials shall be compatible with insulation materials, jackets, and substrates and for bonding insulation to itself and to surfaces to be insulated, unless otherwise indicated.
- B. Cellular-Glass, Phenolic, Polyisocyanurate, and Polystyrene Adhesive: Solvent-based resin adhesive, with a service temperature range of minus 75 to plus 300 deg F.
1. Products: Subject to compliance with requirements, provide one of the following available products that may be incorporated into the Work include, but are not limited to, the following:
 - a. Childers Products, Division of ITW; CP-96.
 - b. Foster Products Corporation, H. B. Fuller Company; 81-33.
 2. For indoor applications, use adhesive that has a VOC content of 50 g/L or less when calculated according to 40 CFR 59, Subpart D (EPA Method 24).
- C. Flexible Elastomeric and Polyolefin Adhesive: Comply with MIL-A-24179A, Type II, Class I.
1. Products: Subject to compliance with requirements, provide one of the following:
 - a. Aeroflex USA Inc.; AeroSeal.
 - b. Armacell LCC; 520 Adhesive.
 - c. Foster Products Corporation, H. B. Fuller Company; 85-75.
 - d. RBX Corporation; Rubatex Contact Adhesive.

2. For indoor applications, use adhesive that has a VOC content of 50 g/L or less when calculated according to 40 CFR 59, Subpart D (EPA Method 24).
- D. Mineral-Fiber Adhesive: Comply with MIL-A-3316C, Class 2, Grade A.
1. Products: Subject to compliance with requirements, provide one of the following:
 - a. Childers Products, Division of ITW; CP-82.
 - b. Foster Products Corporation, H. B. Fuller Company; 85-20.
 - c. ITW TACC, Division of Illinois Tool Works; S-90/80.
 - d. Marathon Industries, Inc.; 225.
 - e. Mon-Eco Industries, Inc.; 22-25.
 2. For indoor applications, use adhesive that has a VOC content of 80 g/L or less when calculated according to 40 CFR 59, Subpart D (EPA Method 24).
- E. ASJ Adhesive, and FSK and PVDC Jacket Adhesive: Comply with MIL-A-3316C, Class 2, Grade A for bonding insulation jacket lap seams and joints.
1. Products: Subject to compliance with requirements, provide one of the following:
 - a. Childers Products, Division of ITW; CP-82.
 - b. Foster Products Corporation, H. B. Fuller Company; 85-20.
 - c. ITW TACC, Division of Illinois Tool Works; S-90/80.
 - d. Marathon Industries, Inc.; 225.
 - e. Mon-Eco Industries, Inc.; 22-25.
 2. For indoor applications, use adhesive that has a VOC content of 50 g/L or less when calculated according to 40 CFR 59, Subpart D (EPA Method 24).
- F. PVC Jacket Adhesive: Compatible with PVC jacket.
1. Products: Subject to compliance with requirements, provide one of the following:
 - a. Dow Chemical Company (The); 739, Dow Silicone.
 - b. Johns-Manville; Zeston Perma-Weld, CEEL-TITE Solvent Welding Adhesive.
 - c. P.I.C. Plastics, Inc.; Welding Adhesive.
 - d. Speedline Corporation; Speedline Vinyl Adhesive.
 2. For indoor applications, use adhesive that has a VOC content of 50 g/L or less when calculated according to 40 CFR 59, Subpart D (EPA Method 24).

2.4 MASTICS

- A. Materials shall be compatible with insulation materials, jackets, and substrates; comply with MIL-C-19565C, Type II.
1. For indoor applications, use mastics that have a VOC content of <Insert value> g/L or less when calculated according to 40 CFR 59, Subpart D (EPA Method 24).
- B. Vapor-Barrier Mastic: Water based; suitable for indoor and outdoor use on below ambient services.
1. Products: Subject to compliance with requirements, provide one of the following:
 - a. Childers Products, Division of ITW; CP-35.
 - b. Foster Products Corporation, H. B. Fuller Company; 30-90.
 - c. ITW TACC, Division of Illinois Tool Works; CB-50.
 - d. Marathon Industries, Inc.; 590.
 - e. Mon-Eco Industries, Inc.; 55-40.
 - f. Vimasco Corporation; 749.
 2. Water-Vapor Permeance: ASTM E 96, Procedure B, 0.013 perm at 43-mil dry film thickness.
 3. Service Temperature Range: Minus 20 to plus 180 deg F.
 4. Solids Content: ASTM D 1644, 59 percent by volume and 71 percent by weight.
 5. Color: White.
- C. Vapor-Barrier Mastic: Solvent based; suitable for indoor use on below ambient services.
1. Products: Subject to compliance with requirements, provide one of the following:
 - a. Childers Products, Division of ITW; CP-30.
 - b. Foster Products Corporation, H. B. Fuller Company; 30-35.
 - c. ITW TACC, Division of Illinois Tool Works; CB-25.
 - d. Marathon Industries, Inc.; 501.

- e. Mon-Eco Industries, Inc.; 55-10.
 2. Water-Vapor Permeance: ASTM F 1249, 0.05 perm at 35-mil dry film thickness.
 3. Service Temperature Range: 0 to 180 deg F.
 4. Solids Content: ASTM D 1644, 44 percent by volume and 62 percent by weight.
 5. Color: White.
- D. Vapor-Barrier Mastic: Solvent based; suitable for outdoor use on below ambient services.
1. Products: Subject to compliance with requirements, provide one of the following:
 - a. Childers Products, Division of ITW; Encacel.
 - b. Foster Products Corporation, H. B. Fuller Company; 60-95/60-96.
 - c. Marathon Industries, Inc.; 570.
 - d. Mon-Eco Industries, Inc.; 55-70.
 2. Water-Vapor Permeance: ASTM F 1249, 0.05 perm at 30-mil dry film thickness.
 3. Service Temperature Range: Minus 50 to plus 220 deg F.
 4. Solids Content: ASTM D 1644, 33 percent by volume and 46 percent by weight.
 5. Color: White.
- E. Breather Mastic: Water based; suitable for indoor and outdoor use on above ambient services.
1. Products: Subject to compliance with requirements, provide one of the following:
 - a. Childers Products, Division of ITW; CP-10.
 - b. Foster Products Corporation, H. B. Fuller Company; 35-00.
 - c. ITW TACC, Division of Illinois Tool Works; CB-05/15.
 - d. Marathon Industries, Inc.; 550.
 - e. Mon-Eco Industries, Inc.; 55-50.
 - f. Vimasco Corporation; WC-1/WC-5.
 2. Water-Vapor Permeance: ASTM F 1249, 3 perms at 0.0625-inch dry film thickness.
 3. Service Temperature Range: Minus 20 to plus 200 deg F.
 4. Solids Content: 63 percent by volume and 73 percent by weight.
 5. Color: White.

2.5 LAGGING ADHESIVES

- A. Description: Comply with MIL-A-3316C Class I, Grade A and shall be compatible with insulation materials, jackets, and substrates.
1. For indoor applications, use lagging adhesives that have a VOC content of <Insert value> g/L or less when calculated according to 40 CFR 59, Subpart D (EPA Method 24).
 2. Products: Subject to compliance with requirements, provide one of the following:
 - a. Childers Products, Division of ITW; CP-52.
 - b. Foster Products Corporation, H. B. Fuller Company; 81-42.
 - c. Marathon Industries, Inc.; 130.
 - d. Mon-Eco Industries, Inc.; 11-30.
 - e. Vimasco Corporation; 136.
 3. Fire-resistant, water-based lagging adhesive and coating for use indoors to adhere fire-resistant lagging cloths over duct, equipment, and pipe insulation.
 4. Service Temperature Range: Minus 50 to plus 180 deg F.
 5. Color: White.

2.6 SEALANTS

- A. Joint Sealants:
1. Joint Sealants for Cellular-Glass, Phenolic, and Polyisocyanurate Products: Subject to compliance with requirements, provide one of the following:
 - a. Childers Products, Division of ITW; CP-76.
 - b. Foster Products Corporation, H. B. Fuller Company; 30-45.
 - c. Marathon Industries, Inc.; 405.
 - d. Mon-Eco Industries, Inc.; 44-05.
 - e. Pittsburgh Corning Corporation; Pittseal 444.
 - f. Vimasco Corporation; 750.

- B. FSK and Metal Jacket Flashing Sealants:
1. Products: Subject to compliance with requirements, provide one of the following:
 - a. Childers Products, Division of ITW; CP-76-8.
 - b. Foster Products Corporation, H. B. Fuller Company; 95-44.
 - c. Marathon Industries, Inc.; 405.
 - d. Mon-Eco Industries, Inc.; 44-05.
 - e. Vimasco Corporation; 750.
 2. Materials shall be compatible with insulation materials, jackets, and substrates.
 3. Fire- and water-resistant, flexible, elastomeric sealant.
 4. Service Temperature Range: Minus 40 to plus 250 deg F.
 5. Color: Aluminum.
 6. For indoor applications, use sealants that have a VOC content of 250 g/L or less when calculated according to 40 CFR 59, Subpart D (EPA Method 24).
- C. ASJ Flashing Sealants:
1. Products: Subject to compliance with requirements, provide one of the following:
 - a. Childers Products, Division of ITW; CP-76.
 2. Materials shall be compatible with insulation materials, jackets, and substrates.
 3. Fire- and water-resistant, flexible, elastomeric sealant.
 4. Service Temperature Range: Minus 40 to plus 250 deg F.
 5. Color: White.
 6. For indoor applications, use sealants that have a VOC content of 250 g/L or less when calculated according to 40 CFR 59, Subpart D (EPA Method 24).

2.7 FACTORY-APPLIED JACKETS

- A. Insulation system schedules indicate factory-applied jackets on various applications. When factory-applied jackets are indicated, comply with the following:
1. ASJ: White, kraft-paper, fiberglass-reinforced scrim with aluminum-foil backing; complying with ASTM C 1136, Type I.
 2. ASJ-SSL: ASJ with self-sealing, pressure-sensitive, acrylic-based adhesive covered by a removable protective strip; complying with ASTM C 1136, Type I.
 3. FSK Jacket: Aluminum-foil, fiberglass-reinforced scrim with kraft-paper backing; complying with ASTM C 1136, Type II.

2.8 FIELD-APPLIED FABRIC-REINFORCING MESH

- A. Woven Glass-Fiber Fabric for Pipe Insulation: Approximately 2 oz./sq. yd. with a thread count of 10 strands by 10 strands/sq. inch for covering pipe and pipe fittings.
1. Products: Subject to compliance with requirements, provide one of the following:
 - a. Vimasco Corporation; Elastafab 894.
- B. Woven Glass-Fiber Fabric for Duct and Equipment Insulation: Approximately 6 oz./sq. yd. with a thread count of 5 strands by 5 strands/sq. inch for covering equipment.
1. Products: Subject to compliance with requirements, provide one of the following:
 - a. Childers Products, Division of ITW; Chil-Glas No. 5.
- C. Woven Polyester Fabric: Approximately 1 oz./sq. yd. with a thread count of 10 strands by 10 strands/sq. inch, in a Leno weave, for duct, equipment, and pipe.
1. Products: Subject to compliance with requirements, provide one of the following:
 - a. Foster Products Corporation, H. B. Fuller Company; Mast-A-Fab.
 - b. Vimasco Corporation; Elastafab 894.

2.9 FIELD-APPLIED CLOTHS

- A. Woven Glass-Fiber Fabric: Comply with MIL-C-20079H, Type I, plain weave, and presized a minimum of 8 oz./sq. yd..

1. Products: Subject to compliance with requirements, provide one of the following:
 - a. Alpha Associates, Inc.; Alpha-Maritex 84215 and 84217/9485RW, Luben 59.

2.10 FIELD-APPLIED JACKETS

- A. Field-applied jackets shall comply with ASTM C 921, Type I, unless otherwise indicated.
- B. FSK Jacket: Aluminum-foil-face, fiberglass-reinforced scrim with kraft-paper backing.
- C. Metal Jacket:
 1. Products: Subject to compliance with requirements, provide one of the following:
 - a. Childers Products, Division of ITW; Metal Jacketing Systems.
 - b. PABCO Metals Corporation; Surefit.
 - c. RPR Products, Inc.; Insul-Mate.
 2. Aluminum Jacket: Comply with ASTM B 209, Alloy 3003, 3005, 3105 or 5005, Temper H-14.
 - a. Sheet and roll stock ready for shop or field sizing.
 - b. Finish and thickness are indicated in field-applied jacket schedules.
 - c. Moisture Barrier for Indoor Applications: 1-mil- thick, heat-bonded polyethylene and kraft paper.
 - d. Moisture Barrier for Outdoor Applications: 3-mil- thick, heat-bonded polyethylene and kraft paper.
 - e. Factory-Fabricated Fitting Covers:
 - 1) Same material, finish, and thickness as jacket.
 - 2) Preformed 2-piece or gore, 45- and 90-degree, short- and long-radius elbows.
 - 3) Tee covers.
 - 4) Flange and union covers.
 - 5) End caps.
 - 6) Beveled collars.
 - 7) Valve covers.
 - 8) Field fabricate fitting covers only if factory-fabricated fitting covers are not available.
- D. Underground Direct-Buried Jacket: 125-mil- thick vapor barrier and waterproofing membrane consisting of a rubberized bituminous resin reinforced with a woven-glass fiber or polyester scrim and laminated aluminum foil.
 1. Products: Subject to compliance with requirements, provide one of the following:
 - a. Pittsburgh Corning Corporation; Pittwrap.
 - b. Polyguard; Insulrap No Torch 125.

2.11 TAPES

- A. ASJ Tape: White vapor-retarder tape matching factory-applied jacket with acrylic adhesive, complying with ASTM C 1136.
 1. Products: Subject to compliance with requirements, provide one of the following:
 - a. Avery Dennison Corporation, Specialty Tapes Division; Fasson 0835.
 - b. Compac Corp.; 104 and 105.
 - c. Ideal Tape Co., Inc., an American Biltrite Company; 428 AWF ASJ.
 - d. Venture Tape; 1540 CW Plus, 1542 CW Plus, and 1542 CW Plus/SQ.
 2. Width: 3 inches.
 3. Thickness: 11.5 mils.
 4. Adhesion: 90 ounces force/inch in width.
 5. Elongation: 2 percent.
 6. Tensile Strength: 40 lbf/inch in width.
 7. ASJ Tape Disks and Squares: Precut disks or squares of ASJ tape.
- B. FSK Tape: Foil-face, vapor-retarder tape matching factory-applied jacket with acrylic adhesive; complying with ASTM C 1136.
 1. Products: Subject to compliance with requirements, provide one of the following:
 - a. Avery Dennison Corporation, Specialty Tapes Division; Fasson 0827.

- b. Compac Corp.; 110 and 111.
 - c. Ideal Tape Co., Inc., an American Bilrite Company; 491 AWF FSK.
 - d. Venture Tape; 1525 CW, 1528 CW, and 1528 CW/SQ.
2. Width: 3 inches.
 3. Thickness: 6.5 mils.
 4. Adhesion: 90 ounces force/inch in width.
 5. Elongation: 2 percent.
 6. Tensile Strength: 40 lbf/inch in width.
 7. FSK Tape Disks and Squares: Precut disks or squares of FSK tape.
- C. Aluminum-Foil Tape: Vapor-retarder tape with acrylic adhesive.
1. Products: Subject to compliance with requirements, provide one of the following:
 - a. Avery Dennison Corporation, Specialty Tapes Division; Fasson 0800.
 - b. Compac Corp.; 120.
 - c. Ideal Tape Co., Inc., an American Bilrite Company; 488 AWF.
 - d. Venture Tape; 3520 CW.
 2. Width: 3 inches.
 3. Thickness: 3.7 mils.
 4. Adhesion: 100 ounces force/inch in width.
 5. Elongation: 5 percent.
 6. Tensile Strength: 34 lbf/inch in width.

2.12 SECUREMENTS

A. Bands:

1. Products: Subject to compliance with requirements, provide one of the following:
 - a. Childers Products; Bands.
 - b. PABCO Metals Corporation; Bands.
 - c. RPR Products, Inc.; Bands.
2. Stainless Steel: ASTM A 167 or ASTM A 240/A 240M, Type 304 or Type 316; 0.015 inch thick, 3/4 inch wide with wing or closed seal.
3. Springs: Twin spring set constructed of stainless steel with ends flat and slotted to accept metal bands. Spring size determined by manufacturer for application.

B. Insulation Pins and Hangers:

1. Capacitor-Discharge-Weld Pins: Copper- or zinc-coated steel pin, fully annealed for capacitor-discharge welding, 0.135-inch- diameter shank, length to suit depth of insulation indicated.
 - a. Products: Subject to compliance with requirements, provide one of the following:
 - 1) AGM Industries, Inc.; CWP-1.
 - 2) GEMCO; CD.
 - 3) Midwest Fasteners, Inc.; CD.
 - 4) Nelson Stud Welding; TPA, TPC, and TPS.
2. Cupped-Head, Capacitor-Discharge-Weld Pins: Copper- or zinc-coated steel pin, fully annealed for capacitor-discharge welding, 0.135-inch- diameter shank, length to suit depth of insulation indicated with integral 1-1/2-inch galvanized carbon-steel washer.
 - a. Products: Subject to compliance with requirements, provide one of the following:
 - 1) AGM Industries, Inc.; CWP-1.
 - 2) GEMCO; Cupped Head Weld Pin.
 - 3) Midwest Fasteners, Inc.; Cupped Head.
 - 4) Nelson Stud Welding; CHP.
3. Metal, Adhesively Attached, Perforated-Base Insulation Hangers: Baseplate welded to projecting spindle that is capable of holding insulation, of thickness indicated, securely in position indicated when self-locking washer is in place. Comply with the following requirements:
 - a. Products: Subject to compliance with requirements, provide one of the following:
 - 1) AGM Industries, Inc.; Tactoo Insul-Hangers, Series T.
 - 2) GEMCO; Perforated Base.
 - 3) Midwest Fasteners, Inc.; Spindle.
 - b. Baseplate: Perforated, galvanized carbon-steel sheet, 0.030 inch thick by 2 inches square.
 - c. Spindle: Copper- or zinc-coated, low carbon steel or Aluminum, fully annealed, 0.106-inch-diameter shank, length to suit depth of insulation indicated.

- d. Adhesive: Recommended by hanger manufacturer. Product with demonstrated capability to bond insulation hanger securely to substrates indicated without damaging insulation, hangers, and substrates.
- 4. Insulation-Retaining Washers: Self-locking washers formed from 0.016-inch- thick, aluminum sheet, with beveled edge sized as required to hold insulation securely in place but not less than 1-1/2 inches in diameter.
 - a. Products: Subject to compliance with requirements, provide one of the following:
 - 1) AGM Industries, Inc.; RC-150.
 - 2) GEMCO; R-150.
 - 3) Midwest Fasteners, Inc.; WA-150.
 - 4) Nelson Stud Welding; Speed Clips.
 - b. Protect ends with capped self-locking washers incorporating a spring steel insert to ensure permanent retention of cap in exposed locations.
- C. Staples: Outward-clinching insulation staples, nominal 3/4-inch- wide, stainless steel or Monel.
- D. Wire: 0.080-inch nickel-copper alloy.
 - 1. Manufacturers: Subject to compliance with requirements, provide products by one of the following:
 - a. C & F Wire.
 - b. Childers Products.
 - c. PABCO Metals Corporation.
 - d. RPR Products, Inc.

2.13 CORNER ANGLES

- A. PVC Corner Angles: 30 mils thick, minimum 1 by 1 inch, PVC according to ASTM D 1784, Class 16354-C. White or color-coded to match adjacent surface.
- B. Aluminum Corner Angles: 0.040 inch thick, minimum 1 by 1 inch, aluminum according to ASTM B 209, Alloy 3003, 3005, 3105 or 5005; Temper H-14.
- C. Stainless-Steel Corner Angles: 0.024 inch thick, minimum 1 by 1 inch, stainless steel according to ASTM A 167 or ASTM A 240/A 240M, Type 304 or 316.

PART 3 - EXECUTION

3.1 EXAMINATION

- A. Examine substrates and conditions for compliance with requirements for installation and other conditions affecting performance of insulation application.
 - 1. Verify that systems and equipment to be insulated have been tested and are free of defects.
 - 2. Verify that surfaces to be insulated are clean and dry.
 - 3. Proceed with installation only after unsatisfactory conditions have been corrected.

3.2 PREPARATION

- A. Surface Preparation: Clean and dry surfaces to receive insulation. Remove materials that will adversely affect insulation application.
- B. Surface Preparation: Clean and prepare surfaces to be insulated. Before insulating, apply a corrosion coating to insulated surfaces as follows:
 - 1. Stainless Steel: Coat 300 series stainless steel with an epoxy primer 5 mils thick and an epoxy finish 5 mils thick if operating in a temperature range between 140 and 300 deg F. Consult coating manufacturer for appropriate coating materials and application methods for operating temperature range.

2. Carbon Steel: Coat carbon steel operating at a service temperature between 32 and 300 deg F with an epoxy coating. Consult coating manufacturer for appropriate coating materials and application methods for operating temperature range.
- C. Coordinate insulation installation with the trade installing heat tracing. Comply with requirements for heat tracing that apply to insulation.
- D. Mix insulating cements with clean potable water; if insulating cements are to be in contact with stainless-steel surfaces, use demineralized water.

3.3 GENERAL INSTALLATION REQUIREMENTS

- A. Install insulation materials, accessories, and finishes with smooth, straight, and even surfaces; free of voids throughout the length of equipment, ducts and fittings, and piping including fittings, valves, and specialties.
- B. Install insulation materials, forms, vapor barriers or retarders, jackets, and thicknesses required for each item of equipment, duct system, and pipe system as specified in insulation system schedules.
- C. Install accessories compatible with insulation materials and suitable for the service. Install accessories that do not corrode, soften, or otherwise attack insulation or jacket in either wet or dry state.
- D. Install insulation with longitudinal seams at top and bottom of horizontal runs.
- E. Install multiple layers of insulation with longitudinal and end seams staggered.
- F. Do not weld brackets, clips, or other attachment devices to piping, fittings, and specialties.
- G. Keep insulation materials dry during application and finishing.
- H. Install insulation with tight longitudinal seams and end joints. Bond seams and joints with adhesive recommended by insulation material manufacturer.
- I. Install insulation with least number of joints practical.
- J. Where vapor barrier is indicated, seal joints, seams, and penetrations in insulation at hangers, supports, anchors, and other projections with vapor-barrier mastic.
 1. Install insulation continuously through hangers and around anchor attachments.
 2. For insulation application where vapor barriers are indicated, extend insulation on anchor legs from point of attachment to supported item to point of attachment to structure. Taper and seal ends at attachment to structure with vapor-barrier mastic.
 3. Install insert materials and install insulation to tightly join the insert. Seal insulation to insulation inserts with adhesive or sealing compound recommended by insulation material manufacturer.
 4. Cover inserts with jacket material matching adjacent pipe insulation. Install shields over jacket, arranged to protect jacket from tear or puncture by hanger, support, and shield.
- K. Apply adhesives, mastics, and sealants at manufacturer's recommended coverage rate and wet and dry film thicknesses.
- L. Install insulation with factory-applied jackets as follows:
 1. Draw jacket tight and smooth.
 2. Cover circumferential joints with 3-inch- wide strips, of same material as insulation jacket. Secure strips with adhesive and outward clinching staples along both edges of strip, spaced 4 inches o.c.
 3. Overlap jacket longitudinal seams at least 1-1/2 inches. Install insulation with longitudinal seams at bottom of pipe. Clean and dry surface to receive self-sealing lap. Staple laps with outward clinching staples along edge at 2 inches o.c.
 - a. For below ambient services, apply vapor-barrier mastic over staples.

4. Cover joints and seams with tape as recommended by insulation material manufacturer to maintain vapor seal.
 5. Where vapor barriers are indicated, apply vapor-barrier mastic on seams and joints and at ends adjacent to duct and pipe flanges and fittings.
- M. Cut insulation in a manner to avoid compressing insulation more than 75 percent of its nominal thickness.
- N. Finish installation with systems at operating conditions. Repair joint separations and cracking due to thermal movement.
- O. Repair damaged insulation facings by applying same facing material over damaged areas. Extend patches at least 4 inches beyond damaged areas. Adhere, staple, and seal patches similar to butt joints.
- P. For above ambient services, do not install insulation to the following:
1. Vibration-control devices.
 2. Testing agency labels and stamps.
 3. Nameplates and data plates.
 4. Manholes.
 5. Handholes.
 6. Cleanouts.

3.4 PENETRATIONS

- A. Insulation Installation at Roof Penetrations: Install insulation continuously through roof penetrations.
1. Seal penetrations with flashing sealant.
 2. For applications requiring only indoor insulation, terminate insulation above roof surface and seal with joint sealant. For applications requiring indoor and outdoor insulation, install insulation for outdoor applications tightly joined to indoor insulation ends. Seal joint with joint sealant.
 3. Extend jacket of outdoor insulation outside roof flashing at least 2 inches below top of roof flashing.
 4. Seal jacket to roof flashing with flashing sealant.
- B. Insulation Installation at Underground Exterior Wall Penetrations: Terminate insulation flush with sleeve seal. Seal terminations with flashing sealant.
- C. Insulation Installation at Aboveground Exterior Wall Penetrations: Install insulation continuously through wall penetrations.
1. Seal penetrations with flashing sealant.
 2. For applications requiring only indoor insulation, terminate insulation inside wall surface and seal with joint sealant. For applications requiring indoor and outdoor insulation, install insulation for outdoor applications tightly joined to indoor insulation ends. Seal joint with joint sealant.
 3. Extend jacket of outdoor insulation outside wall flashing and overlap wall flashing at least 2 inches.
 4. Seal jacket to wall flashing with flashing sealant.
- D. Insulation Installation at Interior Wall and Partition Penetrations (That Are Not Fire Rated): Install insulation continuously through walls and partitions.
- E. Insulation Installation at Fire-Rated Wall and Partition Penetrations: Install insulation continuously through penetrations of fire-rated walls and partitions. Terminate insulation at fire damper sleeves for fire-rated wall and partition penetrations. Externally insulate damper sleeves to match adjacent insulation and overlap duct insulation at least 2 inches.
1. Comply with requirements in Division 07 Section "Penetration Firestopping" firestopping and fire-resistive joint sealers.
- F. Insulation Installation at Floor Penetrations:
1. Duct: Install insulation continuously through floor penetrations that are not fire rated. For penetrations through fire-rated assemblies, terminate insulation at fire damper sleeves and externally insulate damper sleeve beyond floor to match adjacent duct insulation. Overlap damper sleeve and duct insulation at least 2 inches.
 2. Pipe: Install insulation continuously through floor penetrations.

3. Seal penetrations through fire-rated assemblies. Comply with requirements in Division 07 Section "Penetration Firestopping."

3.5 GENERAL PIPE INSULATION INSTALLATION

- A. Requirements in this article generally apply to all insulation materials except where more specific requirements are specified in various pipe insulation material installation articles.
- B. Insulation Installation on Fittings, Valves, Strainers, Flanges, and Unions:
 1. Install insulation over fittings, valves, strainers, flanges, unions, and other specialties with continuous thermal and vapor-retarder integrity, unless otherwise indicated.
 2. Insulate pipe elbows using preformed fitting insulation or mitered fittings made from same material and density as adjacent pipe insulation. Each piece shall be butted tightly against adjoining piece and bonded with adhesive. Fill joints, seams, voids, and irregular surfaces with insulating cement finished to a smooth, hard, and uniform contour that is uniform with adjoining pipe insulation.
 3. Insulate tee fittings with preformed fitting insulation or sectional pipe insulation of same material and thickness as used for adjacent pipe. Cut sectional pipe insulation to fit. Butt each section closely to the next and hold in place with tie wire. Bond pieces with adhesive.
 4. Insulate valves using preformed fitting insulation or sectional pipe insulation of same material, density, and thickness as used for adjacent pipe. Overlap adjoining pipe insulation by not less than two times the thickness of pipe insulation, or one pipe diameter, whichever is thicker. For valves, insulate up to and including the bonnets, valve stuffing-box studs, bolts, and nuts. Fill joints, seams, and irregular surfaces with insulating cement.
 5. Insulate strainers using preformed fitting insulation or sectional pipe insulation of same material, density, and thickness as used for adjacent pipe. Overlap adjoining pipe insulation by not less than two times the thickness of pipe insulation, or one pipe diameter, whichever is thicker. Fill joints, seams, and irregular surfaces with insulating cement. Insulate strainers so strainer basket flange or plug can be easily removed and replaced without damaging the insulation and jacket. Provide a removable reusable insulation cover. For below ambient services, provide a design that maintains vapor barrier.
 6. Insulate flanges and unions using a section of oversized preformed pipe insulation. Overlap adjoining pipe insulation by not less than two times the thickness of pipe insulation, or one pipe diameter, whichever is thicker.
 7. Cover segmented insulated surfaces with a layer of finishing cement and coat with a mastic. Install vapor-barrier mastic for below ambient services and a breather mastic for above ambient services. Reinforce the mastic with fabric-reinforcing mesh. Trowel the mastic to a smooth and well-shaped contour.
 8. For services not specified to receive a field-applied jacket except for flexible elastomeric and polyolefin, install fitted PVC cover over elbows, tees, strainers, valves, flanges, and unions. Terminate ends with PVC end caps. Tape PVC covers to adjoining insulation facing using PVC tape.
 9. Stencil or label the outside insulation jacket of each union with the word "UNION." Match size and color of pipe labels.
- C. Insulate instrument connections for thermometers, pressure gages, pressure temperature taps, test connections, flow meters, sensors, switches, and transmitters on insulated pipes, vessels, and equipment. Shape insulation at these connections by tapering it to and around the connection with insulating cement and finish with finishing cement, mastic, and flashing sealant.
- D. Install removable insulation covers at locations indicated. Installation shall conform to the following:
 1. Make removable flange and union insulation from sectional pipe insulation of same thickness as that on adjoining pipe. Install same insulation jacket as adjoining pipe insulation.
 2. When flange and union covers are made from sectional pipe insulation, extend insulation from flanges or union long at least two times the insulation thickness over adjacent pipe insulation on each side of flange or union. Secure flange cover in place with stainless-steel or aluminum bands. Select band material compatible with insulation and jacket.
 3. Construct removable valve insulation covers in same manner as for flanges except divide the two-part section on the vertical center line of valve body.
 4. When covers are made from block insulation, make two halves, each consisting of mitered blocks wired to stainless-steel fabric. Secure this wire frame, with its attached insulation, to flanges with

tie wire. Extend insulation at least 2 inches over adjacent pipe insulation on each side of valve. Fill space between flange or union cover and pipe insulation with insulating cement. Finish cover assembly with insulating cement applied in two coats. After first coat is dry, apply and trowel second coat to a smooth finish.

5. Unless a PVC jacket is indicated in field-applied jacket schedules, finish exposed surfaces with a metal jacket.

3.6 FLEXIBLE ELASTOMERIC INSULATION INSTALLATION

- A. Seal longitudinal seams and end joints with manufacturer's recommended adhesive to eliminate openings in insulation that allow passage of air to surface being insulated.
- B. Insulation Installation on Pipe Flanges:
 1. Install pipe insulation to outer diameter of pipe flange.
 2. Make width of insulation section same as overall width of flange and bolts, plus twice the thickness of pipe insulation.
 3. Fill voids between inner circumference of flange insulation and outer circumference of adjacent straight pipe segments with cut sections of sheet insulation of same thickness as pipe insulation.
 4. Secure insulation to flanges and seal seams with manufacturer's recommended adhesive to eliminate openings in insulation that allow passage of air to surface being insulated.
- C. Insulation Installation on Pipe Fittings and Elbows:
 1. Install mitered sections of pipe insulation.
 2. Secure insulation materials and seal seams with manufacturer's recommended adhesive to eliminate openings in insulation that allow passage of air to surface being insulated.
- D. Insulation Installation on Valves and Pipe Specialties:
 1. Install preformed valve covers manufactured of same material as pipe insulation when available.
 2. When preformed valve covers are not available, install cut sections of pipe and sheet insulation to valve body. Arrange insulation to permit access to packing and to allow valve operation without disturbing insulation.
 3. Install insulation to flanges as specified for flange insulation application.
 4. Secure insulation to valves and specialties and seal seams with manufacturer's recommended adhesive to eliminate openings in insulation that allow passage of air to surface being insulated.

3.7 MINERAL-FIBER INSULATION INSTALLATION

- A. Insulation Installation on Straight Pipes and Tubes:
 1. Secure each layer of preformed pipe insulation to pipe with wire or bands and tighten bands without deforming insulation materials.
 2. Where vapor barriers are indicated, seal longitudinal seams, end joints, and protrusions with vapor-barrier mastic and joint sealant.
 3. For insulation with factory-applied jackets on above ambient surfaces, secure laps with outward clinched staples at 6 inches o.c.
 4. For insulation with factory-applied jackets on below ambient surfaces, do not staple longitudinal tabs but secure tabs with additional adhesive as recommended by insulation material manufacturer and seal with vapor-barrier mastic and flashing sealant.
- B. Insulation Installation on Pipe Flanges:
 1. Install preformed pipe insulation to outer diameter of pipe flange.
 2. Make width of insulation section same as overall width of flange and bolts, plus twice the thickness of pipe insulation.
 3. Fill voids between inner circumference of flange insulation and outer circumference of adjacent straight pipe segments with mineral-fiber blanket insulation.
 4. Install jacket material with manufacturer's recommended adhesive, overlap seams at least 1 inch, and seal joints with flashing sealant.
- C. Insulation Installation on Pipe Fittings and Elbows:

1. Install preformed sections of same material as straight segments of pipe insulation when available.
 2. When preformed insulation elbows and fittings are not available, install mitered sections of pipe insulation, to a thickness equal to adjoining pipe insulation. Secure insulation materials with wire or bands.
- D. Insulation Installation on Valves and Pipe Specialties:
1. Install preformed sections of same material as straight segments of pipe insulation when available.
 2. When preformed sections are not available, install mitered sections of pipe insulation to valve body.
 3. Arrange insulation to permit access to packing and to allow valve operation without disturbing insulation.
 4. Install insulation to flanges as specified for flange insulation application.
- E. Blanket Insulation Installation on Ducts and Plenums: Secure with adhesive and insulation pins.
1. Apply adhesives according to manufacturer's recommended coverage rates per unit area, for 50 percent coverage of duct and plenum surfaces.
 2. Apply adhesive to entire circumference of ducts and to all surfaces of fittings and transitions.
 3. Install either capacitor-discharge-weld pins and speed washers or cupped-head, capacitor-discharge-weld pins on sides and bottom of horizontal ducts and sides of vertical ducts as follows:
 - a. On duct sides with dimensions 18 inches and smaller, place pins along longitudinal centerline of duct. Space 3 inches maximum from insulation end joints, and 16 inches o.c.
 - b. On duct sides with dimensions larger than 18 inches, place pins 16 inches o.c. each way, and 3 inches maximum from insulation joints. Install additional pins to hold insulation tightly against surface at cross bracing.
 - c. Pins may be omitted from top surface of horizontal, rectangular ducts and plenums.
 - d. Do not overcompress insulation during installation.
 - e. Impale insulation over pins and attach speed washers.
 - f. Cut excess portion of pins extending beyond speed washers or bend parallel with insulation surface. Cover exposed pins and washers with tape matching insulation facing.
 4. For ducts and plenums with surface temperatures below ambient, install a continuous unbroken vapor barrier. Create a facing lap for longitudinal seams and end joints with insulation by removing 2 inches from 1 edge and 1 end of insulation segment. Secure laps to adjacent insulation section with 1/2-inch outward-clinching staples, 1 inch o.c. Install vapor barrier consisting of factory- or field-applied jacket, adhesive, tape vapor-barrier mastic, and sealant at joints, seams, and protrusions.
 - a. Repair punctures, tears, and penetrations with tape and mastic to maintain vapor-barrier seal.
 - b. Install vapor stops for ductwork and plenums operating below 50 deg F at 18-foot intervals. Vapor stops shall consist of vapor-barrier mastic applied in a Z-shaped pattern over insulation face, along butt end of insulation, and over the surface. Cover insulation face and surface to be insulated a width equal to 2 times the insulation thickness but not less than 3 inches.
 5. Overlap unfaced blankets a minimum of 2 inches on longitudinal seams and end joints. At end joints, secure with steel bands spaced a maximum of 18 inches o.c.
 6. Install insulation on rectangular duct elbows and transitions with a full insulation section for each surface. Install insulation on round and flat-oval duct elbows with individually mitered gores cut to fit the elbow.
 7. Insulate duct stiffeners, hangers, and flanges that protrude beyond insulation surface with 6-inch-wide strips of same material used to insulate duct. Secure on alternating sides of stiffener, hanger, and flange with pins spaced 6 inches o.c.

3.8 FIELD-APPLIED JACKET INSTALLATION

- A. Where glass-cloth jackets are indicated, install directly over bare insulation or insulation with factory-applied jackets.
1. Draw jacket smooth and tight to surface with 2-inch overlap at seams and joints.
 2. Embed glass cloth between two 0.062-inch-thick coats of lagging adhesive.
 3. Completely encapsulate insulation with coating, leaving no exposed insulation.
- B. Where FSK jackets are indicated, install as follows:
1. Draw jacket material smooth and tight.

2. Install lap or joint strips with same material as jacket.
3. Secure jacket to insulation with manufacturer's recommended adhesive.
4. Install jacket with 1-1/2-inch laps at longitudinal seams and 3-inch- wide joint strips at end joints.
5. Seal openings, punctures, and breaks in vapor-retarder jackets and exposed insulation with vapor-barrier mastic.

C. Where PVC jackets are indicated, install with 1-inch overlap at longitudinal seams and end joints; for horizontal applications, install with longitudinal seams along top and bottom of tanks and vessels. Seal with manufacturer's recommended adhesive.

1. Apply two continuous beads of adhesive to seams and joints, one bead under lap and the finish bead along seam and joint edge.

D. Where metal jackets are indicated, install with 2-inch overlap at longitudinal seams and end joints. Overlap longitudinal seams arranged to shed water. Seal end joints with weatherproof sealant recommended by insulation manufacturer. Secure jacket with stainless-steel bands 12 inches o.c. and at end joints.

3.9 FINISHES

A. Duct, Equipment, and Pipe Insulation with ASJ, Glass-Cloth, or Other Paintable Jacket Material: Paint jacket with paint system identified below and as specified in Division 09 painting Sections.

1. Flat Acrylic Finish: Two finish coats over a primer that is compatible with jacket material and finish coat paint. Add fungicidal agent to render fabric mildew proof.
 - a. Finish Coat Material: Interior, flat, latex-emulsion size.

B. Flexible Elastomeric Thermal Insulation: After adhesive has fully cured, apply two coats of insulation manufacturer's recommended protective coating.

C. Color: Final color as selected by Architect. Vary first and second coats to allow visual inspection of the completed Work.

D. Do not field paint aluminum or stainless-steel jackets.

3.10 DUCT INSULATION SCHEDULE, GENERAL

A. Plenums and Ducts Requiring Insulation:

1. Indoor, concealed supply air, return air and outside air.
- 2.

B. Items Not Insulated:

1. Exposed duct in the Gym.
2. Exposed duct specified to have duct liner.
3. Metal ducts with duct liner of sufficient thickness to comply with energy code and ASHRAE/IESNA 90.1.
4. Factory-insulated flexible ducts.
5. Factory-insulated plenums and casings.
6. Flexible connectors.
7. Vibration-control devices.
8. Factory-insulated access panels and doors.

3.11 INDOOR DUCT AND PLENUM INSULATION SCHEDULE

A. Concealed rectangular, round and flat-oval, supply-air, return air, exhaust air and outside air duct insulation shall be the following:

1. Mineral-Fiber Blanket: 2.2 inches thick and 0.75-lb/cu. ft. nominal density.

3.12 OUTDOOR DUCT AND PLENUM INSULATION SCHEDULE

- A. Concealed rectangular, round and flat-oval, supply-air, return air, exhaust air and outside air duct insulation shall be the following:
 - 1. Rigid Polystyrene: 3 inches thick.
 - 2. Exterior jacketing.

3.13 PIPING INSULATION SCHEDULE, GENERAL

- A. Acceptable preformed pipe and tubular insulation materials and thicknesses are identified for each piping system and pipe size range. If more than one material is listed for a piping system, selection from materials listed is Contractor's option.
- B. Items Not Insulated: Unless otherwise indicated, do not install insulation on the following:
 - 1. Drainage piping located in crawl spaces.
 - 2. Underground piping.
 - 3. Chrome-plated pipes and fittings unless there is a potential for personnel injury.

3.14 INDOOR PIPING INSULATION SCHEDULE

- A. Condensate and Equipment Drain Water below 60 Deg F:
 - 1. All Pipe Sizes: Insulation shall be the following:
 - a. Flexible Elastomeric: 3/4 inch thick.
- B. Refrigerant Suction and Hot-Gas Piping:
 - 1. All Pipe Sizes: Insulation shall be the following:
 - a. Flexible Elastomeric: 1 inch thick.
- C. Refrigerant Suction and Hot-Gas Flexible Tubing:
 - 1. All Pipe Sizes: Insulation shall be the following:
 - a. Flexible Elastomeric: 1 inch thick.

3.15 OUTDOOR, ABOVEGROUND PIPING INSULATION SCHEDULE

- A. Refrigerant Suction and Hot-Gas Piping:
 - 1. All Pipe Sizes: Insulation shall be the following:
 - a. Flexible Elastomeric: 2 inches thick.
 - b. Aluminum Jacketing (See below)
- B. Refrigerant Suction and Hot-Gas Flexible Tubing:
 - 1. All Pipe Sizes: Insulation shall be the following:
 - a. Flexible Elastomeric: 2 inches thick.
 - b. Aluminum Jacketing (See below)

3.16 INDOOR, FIELD-APPLIED JACKET SCHEDULE

- A. Install jacket over insulation material. For insulation with factory-applied jacket, install the field-applied jacket over the factory-applied jacket.
- B. If more than one material is listed, selection from materials listed is Contractor's option.
- C. Refrigerant Suction Piping, Exposed:
 - 1. Aluminum, Stucco Embossed with Z-Shaped Locking Seam: 0.024 inch thick.

3.17 OUTDOOR, FIELD-APPLIED JACKET SCHEDULE

- A. Install jacket over insulation material. For insulation with factory-applied jacket, install the field-applied jacket over the factory-applied jacket.
- B. If more than one material is listed, selection from materials listed is Contractor's option.
- C. Piping, Exposed:
 - 1. Aluminum, Stucco Embossed with Z-Shaped Locking Seam: 0.024 inch thick.
- D. Duct, Exposed:
 - 1. VentureClad Plus 1579CW.

END OF SECTION 230700

SECTION 233113 - METAL DUCTS

PART 1 - GENERAL

1.1 RELATED DOCUMENTS

- A. Drawings and general provisions of the Contract, including General and Supplementary Conditions and Division 01 Specification Sections, apply to this Section.

1.2 SUMMARY

- A. Section Includes:
 - 1. Single-wall rectangular ducts and fittings.
 - 2. Single-wall round fittings.
 - 3. Sheet metal materials.
 - 4. Duct liner.
 - 5. Sealants and gaskets.
 - 6. Hangers and supports.
- B. Related Sections:
 - 1. Division 23 Section "Testing, Adjusting, and Balancing for HVAC" for testing, adjusting, and balancing requirements for metal ducts.
 - 2. Division 23 Section "Air Duct Accessories" for dampers, sound-control devices, duct-mounting access doors and panels, turning vanes, and flexible ducts.

1.3 PERFORMANCE REQUIREMENTS

- A. Delegated Duct Design: Duct construction, including sheet metal thicknesses, seam and joint construction, reinforcements, and hangers and supports, shall comply with SMACNA's "HVAC Duct Construction Standards - Metal and Flexible" and performance requirements and design criteria indicated in "Duct Schedule" Article.
- B. Structural Performance: Duct hangers and supports shall withstand the effects of gravity loads and stresses within limits and under conditions described in SMACNA's "HVAC Duct Construction Standards - Metal and Flexible"
- C. Airstream Surfaces: Surfaces in contact with the airstream shall comply with requirements in ASHRAE 62.1-2004.

1.4 SUBMITTALS

- A. Product Data: For each type of the following products:
 - 1. Liners and adhesives.
 - 2. Sealants and gaskets.
- B. Shop Drawings:
 - 1. Fabrication, assembly, and installation, including plans, elevations, sections, components, and attachments to other work.
 - 2. Factory- and shop-fabricated ducts and fittings.
 - 3. Duct layout indicating sizes, configuration, liner material, and static-pressure classes.
 - 4. Elevation of top of ducts.
 - 5. Dimensions of main duct runs from building grid lines.

6. Fittings.
 7. Reinforcement and spacing.
 8. Seam and joint construction.
 9. Penetrations through fire-rated and other partitions.
 10. Equipment installation based on equipment being used on Project.
 11. Locations for duct accessories, including dampers, turning vanes, and access doors and panels.
 12. Hangers and supports, including methods for duct and building attachment and vibration isolation.
- C. Delegated-Design Submittal:
1. Sheet metal thicknesses.
 2. Joint and seam construction and sealing.
 3. Reinforcement details and spacing.
 4. Materials, fabrication, assembly, and spacing of hangers and supports.
- D. Coordination Drawings: Plans, drawn to scale, on which the following items are shown and coordinated with each other, using input from installers of the items involved:
1. Duct installation in congested spaces, indicating coordination with general construction, building components, and other building services. Indicate proposed changes to duct layout.
 2. Suspended ceiling components.
 3. Structural members to which duct will be attached.
 4. Size and location of initial access modules for acoustical tile.
 5. Penetrations of smoke barriers and fire-rated construction.
 6. Items penetrating finished ceiling including the following:
 - a. Lighting fixtures.
 - b. Air outlets and inlets.
 - c. Speakers.
 - d. Sprinklers.
 - e. Access panels.
 - f. Perimeter moldings.
- E. Welding certificates.
- F. Field quality-control reports.
- 1.5 QUALITY ASSURANCE
- A. Welding Qualifications: Qualify procedures and personnel according to AWS D1.1/D1.1M, "Structural Welding Code - Steel," for hangers and supports. AWS D9.1M/D9.1, "Sheet Metal Welding Code," for duct joint and seam welding.
- B. Welding Qualifications: Qualify procedures and personnel according to the following:
1. AWS D1.1/D1.1M, "Structural Welding Code - Steel," for hangers and supports.
 2. AWS D1.2/D1.2M, "Structural Welding Code - Aluminum," for aluminum supports.
 3. AWS D9.1M/D9.1, "Sheet Metal Welding Code," for duct joint and seam welding.
- C. ASHRAE Compliance: Applicable requirements in ASHRAE 62.1-2004, Section 5 - "Systems and Equipment" and Section 7 - "Construction and System Start-Up."
- D. ASHRAE/IESNA Compliance: Applicable requirements in ASHRAE/IESNA 90.1-2004, Section 6.4.4 - "HVAC System Construction and Insulation."

PART 2 - PRODUCTS

2.1 SINGLE-WALL RECTANGULAR DUCTS AND FITTINGS

- A. General Fabrication Requirements: Comply with SMACNA's "HVAC Duct Construction Standards - Metal and Flexible" based on indicated static-pressure class unless otherwise indicated.
- B. Transverse Joints: Select joint types and fabricate according to SMACNA's "HVAC Duct Construction Standards - Metal and Flexible," Figure 1-4, "Transverse (Girth) Joints," for static-pressure class, applicable sealing requirements, materials involved, duct-support intervals, and other provisions in SMACNA's "HVAC Duct Construction Standards - Metal and Flexible."
- C. Longitudinal Seams: Select seam types and fabricate according to SMACNA's "HVAC Duct Construction Standards - Metal and Flexible," Figure 1-5, "Longitudinal Seams - Rectangular Ducts," for static-pressure class, applicable sealing requirements, materials involved, duct-support intervals, and other provisions in SMACNA's "HVAC Duct Construction Standards - Metal and Flexible."
- D. Elbows, Transitions, Offsets, Branch Connections, and Other Duct Construction: Select types and fabricate according to SMACNA's "HVAC Duct Construction Standards - Metal and Flexible," Chapter 2, "Fittings and Other Construction," for static-pressure class, applicable sealing requirements, materials involved, duct-support intervals, and other provisions in SMACNA's "HVAC Duct Construction Standards - Metal and Flexible."

2.2 SINGLE-WALL ROUND DUCTS AND FITTINGS

- A. General Fabrication Requirements: Comply with SMACNA's "HVAC Duct Construction Standards - Metal and Flexible," Chapter 3, "Round, Oval, and Flexible Duct," based on indicated static-pressure class unless otherwise indicated.
 - 1. Manufacturers: Subject to compliance with requirements, provide products by one of the following:
 - a. Lindab Inc.
 - b. McGill AirFlow LLC.
 - c. SEMCO Incorporated.
 - d. Hamlin, Inc.
 - e. Spiral Manufacturing Co., Inc.
 - f. Prior Approved Equal
- B. Transverse Joints: Select joint types and fabricate according to SMACNA's "HVAC Duct Construction Standards - Metal and Flexible," Figure 3-2, "Transverse Joints - Round Duct," for static-pressure class, applicable sealing requirements, materials involved, duct-support intervals, and other provisions in SMACNA's "HVAC Duct Construction Standards - Metal and Flexible."
 - 1. Transverse Joints in Ducts Larger Than 60 Inches in Diameter: Flanged.
- C. Longitudinal Seams: Select seam types and fabricate according to SMACNA's "HVAC Duct Construction Standards - Metal and Flexible," Figure 3-1, "Seams - Round Duct and Fittings," for static-pressure class, applicable sealing requirements, materials involved, duct-support intervals, and other provisions in SMACNA's "HVAC Duct Construction Standards - Metal and Flexible."
 - 1. Fabricate round ducts larger than 90 inches in diameter with butt-welded longitudinal seams.
 - 2. Fabricate flat-oval ducts larger than 72 inches in width (major dimension) with butt-welded longitudinal seams.
- D. Tees and Laterals: Select types and fabricate according to SMACNA's "HVAC Duct Construction Standards - Metal and Flexible," Figure 3-4, "90 Degree Tees and Laterals," and Figure 3-5, "Conical Tees," for static-pressure class, applicable sealing requirements, materials involved, duct-support intervals, and other provisions in SMACNA's "HVAC Duct Construction Standards - Metal and Flexible."

2.3 SHEET METAL MATERIALS

- A. General Material Requirements: Comply with SMACNA's "HVAC Duct Construction Standards - Metal and Flexible" for acceptable materials, material thicknesses, and duct construction methods unless otherwise indicated. Sheet metal materials shall be free of pitting, seam marks, roller marks, stains, discolorations, and other imperfections.
- B. Galvanized Sheet Steel: Comply with ASTM A 653/A 653M.
 - 1. Galvanized Coating Designation: G90.
 - 2. Finishes for Surfaces Exposed to View: Mill phosphatized.
- C. Carbon-Steel Sheets: Comply with ASTM A 1008/A 1008M, with oiled, matte finish for exposed ducts.
- D. Factory- or Shop-Applied Antimicrobial Coating:
 - 1. Apply to the surface of sheet metal that will form the interior surface of the duct. An untreated clear coating shall be applied to the exterior surface.
 - 2. Antimicrobial compound shall be tested for efficacy by an NRTL and registered by the EPA for use in HVAC systems.
 - 3. Coating containing the antimicrobial compound shall have a hardness of 2H, minimum, when tested according to ASTM D 3363.
 - 4. Surface-Burning Characteristics: Maximum flame-spread index of 25 and maximum smoke-developed index of 50 when tested according to UL 723; certified by an NRTL.
 - 5. Shop-Applied Coating Color: Black.
 - 6. Antimicrobial coating on sheet metal is not required for duct containing liner treated with antimicrobial coating.
- E. Reinforcement Shapes and Plates: ASTM A 36/A 36M, steel plates, shapes, and bars; black and galvanized.
 - 1. Where black- and galvanized-steel shapes and plates are used to reinforce aluminum ducts, isolate the different metals with butyl rubber, neoprene, or EPDM gasket materials.
- F. Tie Rods: Galvanized steel, 1/4-inch minimum diameter for lengths 36 inches or less; 3/8-inch minimum diameter for lengths longer than 36 inches.

2.4 DUCT LINER

- A. Fibrous-Glass Duct Liner: Comply with ASTM C 1071, NFPA 90A, or NFPA 90B; and with NAIMA AH124, "Fibrous Glass Duct Liner Standard."
 - 1. Manufacturers: Subject to compliance with requirements, provide products by one of the following:
 - a. CertainTeed Corporation; Insulation Group.
 - b. Johns Manville.
 - c. Knauf Insulation.
 - d. Owens Corning.
 - 2. Maximum Thermal Conductivity:
 - a. Type I, Flexible: 0.27 Btu x in./h x sq. ft. x deg F at 75 deg F mean temperature.
 - b. Type II, Rigid: 0.23 Btu x in./h x sq. ft. x deg F at 75 deg F mean temperature.
 - 3. Antimicrobial Erosion-Resistant Coating: Apply to the surface of the liner that will form the interior surface of the duct to act as a moisture repellent and erosion-resistant coating. Antimicrobial compound shall be tested for efficacy by an NRTL and registered by the EPA for use in HVAC systems.
 - 4. Liner Adhesive: Comply with NFPA 90A or NFPA 90B and with ASTM C 916.
 - a. For indoor applications, use adhesive that has a VOC content of 80 g/L or less when calculated according to 40 CFR 59, Subpart D (EPA Method 24).
- B. Insulation Pins and Washers:

1. Cupped-Head, Capacitor-Discharge-Weld Pins: Copper- or zinc-coated steel pin, fully annealed for capacitor-discharge welding, 0.135-inch- diameter shank, length to suit depth of insulation indicated with integral 1-1/2-inch galvanized carbon-steel washer.
 2. Insulation-Retaining Washers: Self-locking washers formed from 0.016-inch- thick galvanized steel or aluminum or stainless steel; with beveled edge sized as required to hold insulation securely in place but not less than 1-1/2 inches in diameter.
- C. Shop Application of Duct Liner: Comply with SMACNA's "HVAC Duct Construction Standards - Metal and Flexible," Figure 2-19, "Flexible Duct Liner Installation."
1. Adhere a single layer of indicated thickness of duct liner with at least 90 percent adhesive coverage at liner contact surface area. Attaining indicated thickness with multiple layers of duct liner is prohibited.
 2. Apply adhesive to transverse edges of liner facing upstream that do not receive metal nosing.
 3. Butt transverse joints without gaps, and coat joint with adhesive.
 4. Fold and compress liner in corners of rectangular ducts or cut and fit to ensure butted-edge overlapping.
 5. Do not apply liner in rectangular ducts with longitudinal joints, except at corners of ducts, unless duct size and dimensions of standard liner make longitudinal joints necessary.
 6. Apply adhesive coating on longitudinal seams in ducts with air velocity of 2500 fpm.
 7. Secure liner with mechanical fasteners 4 inches from corners and at intervals not exceeding 12 inches transversely; at 3 inches from transverse joints and at intervals not exceeding 18 inches longitudinally.
 8. Secure transversely oriented liner edges facing the airstream with metal nosings that have either channel or "Z" profiles or are integrally formed from duct wall. Fabricate edge facings at the following locations:
 - a. Fan discharges.
 - b. Intervals of lined duct preceding unlined duct.
 - c. Upstream edges of transverse joints in ducts where air velocities are higher than 2500 fpm or where indicated.
 9. Secure insulation between perforated sheet metal inner duct of same thickness as specified for outer shell. Use mechanical fasteners that maintain inner duct at uniform distance from outer shell without compressing insulation.
 10. Terminate inner ducts with buildouts attached to fire-damper sleeves, dampers, turning vane assemblies, or other devices. Fabricated buildouts (metal hat sections) or other buildout means are optional; when used, secure buildouts to duct walls with bolts, screws, rivets, or welds.

2.5 SEALANT AND GASKETS

- A. General Sealant and Gasket Requirements: Surface-burning characteristics for sealants and gaskets shall be a maximum flame-spread index of 25 and a maximum smoke-developed index of 50 when tested according to UL 723; certified by an NRTL.
- B. Two-Part Tape Sealing System:
1. Tape: Woven cotton fiber impregnated with mineral gypsum and modified acrylic/silicone activator to react exothermically with tape to form hard, durable, airtight seal.
 2. Tape Width: 4 inches.
 3. Sealant: Modified styrene acrylic.
 4. Water resistant.
 5. Mold and mildew resistant.
 6. Maximum Static-Pressure Class: 10-inch wg, positive and negative.
 7. Service: Indoor and outdoor.
 8. Service Temperature: Minus 40 to plus 200 deg F.
 9. Substrate: Compatible with galvanized sheet steel (both PVC coated and bare), stainless steel, or aluminum.
 10. For indoor applications, use sealant that has a VOC content of 250 g/L or less when calculated according to 40 CFR 59, Subpart D (EPA Method 24).
- C. Water-Based Joint and Seam Sealant:

1. Application Method: Brush on.
2. Solids Content: Minimum 65 percent.
3. Shore A Hardness: Minimum 20.
4. Water resistant.
5. Mold and mildew resistant.
6. VOC: Maximum 75 g/L (less water).
7. Maximum Static-Pressure Class: 10-inch wg, positive and negative.
8. Service: Indoor or outdoor.
9. Substrate: Compatible with galvanized sheet steel (both PVC coated and bare), stainless steel, or aluminum sheets.

D. Solvent-Based Joint and Seam Sealant:

1. Application Method: Brush on.
2. Base: Synthetic rubber resin.
3. Solvent: Toluene and heptane.
4. Solids Content: Minimum 60 percent.
5. Shore A Hardness: Minimum 60.
6. Water resistant.
7. Mold and mildew resistant.
8. For indoor applications, use sealant that has a VOC content of 250 g/L or less when calculated according to 40 CFR 59, Subpart D (EPA Method 24).
9. VOC: Maximum 395 g/L.
10. Maximum Static-Pressure Class: 10-inch wg, positive or negative.
11. Service: Indoor or outdoor.
12. Substrate: Compatible with galvanized sheet steel (both PVC coated and bare), stainless steel, or aluminum sheets.

E. Flanged Joint Sealant: Comply with ASTM C 920.

1. General: Single-component, acid-curing, silicone, elastomeric.
2. Type: S.
3. Grade: NS.
4. Class: 25.
5. Use: O.
6. For indoor applications, use sealant that has a VOC content of 250 g/L or less when calculated according to 40 CFR 59, Subpart D (EPA Method 24).

F. Flange Gaskets: Butyl rubber, neoprene, or EPDM polymer with polyisobutylene plasticizer.

G. Round Duct Joint O-Ring Seals:

1. Seal shall provide maximum leakage class of 3 cfm/100 sq. ft. at 1-inch wg and shall be rated for 10-inch wg static-pressure class, positive or negative.
2. EPDM O-ring to seal in concave bead in coupling or fitting spigot.
3. Double-lipped, EPDM O-ring seal, mechanically fastened to factory-fabricated couplings and fitting spigots.

2.6 HANGERS AND SUPPORTS

A. Hanger Rods for Noncorrosive Environments: Cadmium-plated steel rods and nuts.

B. Hanger Rods for Corrosive Environments: Electrogalvanized, all-thread rods or galvanized rods with threads painted with zinc-chromate primer after installation.

C. Strap and Rod Sizes: Comply with SMACNA's "HVAC Duct Construction Standards - Metal and Flexible," Table 4-1, "Rectangular Duct Hangers Minimum Size," and Table 4-2, "Minimum Hanger Sizes for Round Duct."

D. Steel Cables for Galvanized-Steel Ducts: Galvanized steel complying with ASTM A 603.

METAL DUCTS

- E. Steel Cables for Stainless-Steel Ducts: Stainless steel complying with ASTM A 492.
- F. Steel Cable End Connections: Cadmium-plated steel assemblies with brackets, swivel, and bolts designed for duct hanger service; with an automatic-locking and clamping device.
- G. Duct Attachments: Sheet metal screws, blind rivets, or self-tapping metal screws; compatible with duct materials.
- H. Trapeze and Riser Supports:
 - 1. Supports for Galvanized-Steel Ducts: Galvanized-steel shapes and plates.
 - 2. Supports for Stainless-Steel Ducts: Stainless-steel shapes and plates.
 - 3. Supports for Aluminum Ducts: Aluminum or galvanized steel coated with zinc chromate.

PART 3 - EXECUTION

3.1 DUCT INSTALLATION

- A. Drawing plans, schematics, and diagrams indicate general location and arrangement of duct system. Indicated duct locations, configurations, and arrangements were used to size ducts and calculate friction loss for air-handling equipment sizing and for other design considerations. Install duct systems as indicated unless deviations to layout are approved on Shop Drawings and Coordination Drawings.
- B. Install ducts according to SMACNA's "HVAC Duct Construction Standards - Metal and Flexible" unless otherwise indicated.
- C. Install round and flat-oval ducts in maximum practical lengths.
- D. Install ducts with fewest possible joints.
- E. Install factory- or shop-fabricated fittings for changes in direction, size, and shape and for branch connections.
- F. Unless otherwise indicated, install ducts vertically and horizontally, and parallel and perpendicular to building lines.
- G. Install ducts close to walls, overhead construction, columns, and other structural and permanent enclosure elements of building.
- H. Install ducts with a clearance of 1 inch, plus allowance for insulation thickness.
- I. Route ducts to avoid passing through transformer vaults and electrical equipment rooms and enclosures.
- J. Where ducts pass through non-fire-rated interior partitions and exterior walls and are exposed to view, cover the opening between the partition and duct or duct insulation with sheet metal flanges of same metal thickness as the duct. Overlap openings on four sides by at least 1-1/2 inches.
- K. Where ducts pass through fire-rated interior partitions and exterior walls, install fire dampers. Comply with requirements in Division 23 Section "Air Duct Accessories" for fire and smoke dampers.
- L. Protect duct interiors from moisture, construction debris and dust, and other foreign materials. Comply with SMACNA's "Duct Cleanliness for New Construction Guidelines."

3.2 INSTALLATION OF EXPOSED DUCTWORK

- A. Protect ducts exposed in finished spaces from being dented, scratched, or damaged.
- B. Trim duct sealants flush with metal. Create a smooth and uniform exposed bead. Do not use two-part tape sealing system.
- C. Grind welds to provide smooth surface free of burrs, sharp edges, and weld splatter. When welding stainless steel with a No. 3 or 4 finish, grind the welds flush, polish the exposed welds, and treat the welds to remove discoloration caused by welding.
- D. Maintain consistency, symmetry, and uniformity in the arrangement and fabrication of fittings, hangers and supports, duct accessories, and air outlets.
- E. Repair or replace damaged sections and finished work that does not comply with these requirements.

3.3 DUCT SEALING

- A. Seal ducts for duct static-pressure, seal classes, and leakage classes specified in "Duct Schedule" Article according to SMACNA's "HVAC Duct Construction Standards - Metal and Flexible."
- B. Seal ducts to the following seal classes according to SMACNA's "HVAC Duct Construction Standards - Metal and Flexible":
 - 1. Comply with SMACNA's "HVAC Duct Construction Standards - Metal and Flexible."
 - 2. All Ducts: Seal Class A.

3.4 HANGER AND SUPPORT INSTALLATION

- A. Comply with SMACNA's "HVAC Duct Construction Standards - Metal and Flexible," Chapter 4, "Hangers and Supports."
- B. Building Attachments: Concrete inserts, powder-actuated fasteners, or structural-steel fasteners appropriate for construction materials to which hangers are being attached.
 - 1. Where practical, install concrete inserts before placing concrete.
 - 2. Install powder-actuated concrete fasteners after concrete is placed and completely cured.
 - 3. Use powder-actuated concrete fasteners for standard-weight aggregate concretes or for slabs more than 4 inches thick.
 - 4. Do not use powder-actuated concrete fasteners for lightweight-aggregate concretes or for slabs less than 4 inches thick.
 - 5. Do not use powder-actuated concrete fasteners for seismic restraints.
- C. Hanger Spacing: Comply with SMACNA's "HVAC Duct Construction Standards - Metal and Flexible," Table 4-1, "Rectangular Duct Hangers Minimum Size," and Table 4-2, "Minimum Hanger Sizes for Round Duct," for maximum hanger spacing; install hangers and supports within 24 inches of each elbow and within 48 inches of each branch intersection.
- D. Hangers Exposed to View: Threaded rod and angle or channel supports.
- E. Support vertical ducts with steel angles or channel secured to the sides of the duct with welds, bolts, sheet metal screws, or blind rivets; support at each floor and at a maximum intervals of 16 feet.
- F. Install upper attachments to structures. Select and size upper attachments with pull-out, tension, and shear capacities appropriate for supported loads and building materials where used.

3.5 CONNECTIONS

- A. Make connections to equipment with flexible connectors complying with Division 23 Section "Air Duct Accessories."
- B. Comply with SMACNA's "HVAC Duct Construction Standards - Metal and Flexible" for branch, outlet and inlet, and terminal unit connections.

3.6 PAINTING

- A. Paint interior of metal ducts that are visible through registers and grilles and that do not have duct liner. Apply one coat of flat, black, latex paint over a compatible galvanized-steel primer. Paint materials and application requirements are specified in Division 09 painting Sections.

3.7 START UP

- A. Air Balance: Comply with requirements in Division 23 Section "Testing, Adjusting, and Balancing for HVAC."

3.8 DUCT SCHEDULE

- A. Fabricate all ducts with galvanized sheet steel.
- B. Supply Ducts:
 - a. Pressure Class: Positive 3-inch wg.
 - b. Minimum SMACNA Seal Class: A.
- C. Return Ducts:
 - 1. All return ducts:
 - a. Pressure Class: Positive or negative 2-inch wg.
 - b. Minimum SMACNA Seal Class: A.
- D. Exhaust Ducts:
 - 1. Ducts Connected to Exhaust Fans:
 - a. Pressure Class: Negative 2-inch wg.
 - b. Minimum SMACNA Seal Class: A if negative pressure, and A if positive pressure.
- E. Intermediate Reinforcement:
 - 1. Galvanized-Steel Ducts: Galvanized steel.
- F. Elbow Configuration:
 - 1. Rectangular Duct: Comply with SMACNA's "HVAC Duct Construction Standards - Metal and Flexible," Figure 2-2, "Rectangular Elbows."
 - a. Velocity 1000 fpm or Lower:
 - 1) Radius Type RE 1 with minimum 0.5 radius-to-diameter ratio.
 - b. Velocity 1000 to 1500 fpm:
 - 1) Radius Type RE 1 with minimum 1.0 radius-to-diameter ratio.
 - 2) Radius Type RE 3 with minimum 0.5 radius-to-diameter ratio and two vanes.
 - c. Velocity 1500 fpm or Higher:
 - 1) Radius Type RE 1 with minimum 1.5 radius-to-diameter ratio.
 - 2) Radius Type RE 3 with minimum 1.0 radius-to-diameter ratio and two vanes.
 - 2. Rectangular Duct: Comply with SMACNA's "HVAC Duct Construction Standards - Metal and Flexible," Figure 2-2, "Rectangular Elbows."
 - a. Radius Type RE 1 with minimum 1.5 radius-to-diameter ratio.
 - b. Radius Type RE 3 with minimum 1.0 radius-to-diameter ratio and two vanes.

3. Round Duct: Comply with SMACNA's "HVAC Duct Construction Standards - Metal and Flexible," Figure 3-3, "Round Duct Elbows."
 - a. Minimum Radius-to-Diameter Ratio and Elbow Segments: Comply with SMACNA's "HVAC Duct Construction Standards - Metal and Flexible," Table 3-1, "Mitered Elbows." Elbows with less than 90-degree change of direction have proportionately fewer segments.
 - 1) Velocity 1000 fpm or Lower: 0.5 radius-to-diameter ratio and three segments for 90-degree elbow.
 - 2) Velocity 1000 to 1500 fpm: 1.0 radius-to-diameter ratio and four segments for 90-degree elbow.
 - 3) Velocity 1500 fpm or Higher: 1.5 radius-to-diameter ratio and five segments for 90-degree elbow.
 - 4) Radius-to Diameter Ratio: 1.5.
 - b. Round Elbows, 12 Inches and Smaller in Diameter: Stamped or pleated.
 - c. Round Elbows, 14 Inches and Larger in Diameter: Welded.

- G. Branch Configuration:
 1. Rectangular Duct: Comply with SMACNA's "HVAC Duct Construction Standards - Metal and Flexible," Figure 2-6, "Branch Connections."
 - a. Rectangular Main to Rectangular Branch: 45-degree entry.
 - b. Rectangular Main to Round Branch: Spin in.
 2. Round and Flat Oval: Comply with SMACNA's "HVAC Duct Construction Standards - Metal and Flexible," Figure 3-4, "90 Degree Tees and Laterals," and Figure 3-5, "Conical Tees." Saddle taps are permitted in existing duct.
 - a. Velocity 1000 fpm or Lower: 90-degree tap.
 - b. Velocity 1000 to 1500 fpm: Conical tap.
 - c. Velocity 1500 fpm or Higher: 45-degree lateral.

END OF SECTION 233113

SECTION 233300 - AIR DUCT ACCESSORIES

PART 1 - GENERAL

1.1 RELATED DOCUMENTS

- A. Drawings and general provisions of the Contract, including General and Supplementary Conditions and Division 01 Specification Sections, apply to this Section.

1.2 SUMMARY

- A. Section Includes:
 - 1. Manual volume dampers.
 - 2. Flange connectors.
 - 3. Duct-mounted access doors.
 - 4. Flexible connectors.
 - 5. Flexible ducts.
 - 6. Duct accessory hardware.

1.3 SUBMITTALS

- A. Product Data: For each type of product indicated.
 - 1. For duct silencers, include pressure drop and dynamic insertion loss data. Include breakout noise calculations for high transmission loss casings.
- B. Shop Drawings: For duct accessories. Include plans, elevations, sections, details and attachments to other work.
 - 1. Detail duct accessories fabrication and installation in ducts and other construction. Include dimensions, weights, loads, and required clearances; and method of field assembly into duct systems and other construction. Include the following:
 - a. Special fittings.
 - b. Manual volume damper installations.
 - c. Control damper installations.
 - d. Fire-damper, smoke-damper, combination fire- and smoke-damper, ceiling, and corridor damper installations, including sleeves; and duct-mounted access doors and remote damper operators.
 - e. Duct security bars.
 - f. Wiring Diagrams: For power, signal, and control wiring.
- C. Coordination Drawings: Reflected ceiling plans, drawn to scale, on which ceiling-mounted access panels and access doors required for access to duct accessories are shown and coordinated with each other, using input from Installers of the items involved.
- D. Source quality-control reports.
- E. Operation and Maintenance Data: For air duct accessories to include in operation and maintenance manuals.

1.4 QUALITY ASSURANCE

- A. Comply with NFPA 90A, "Installation of Air Conditioning and Ventilating Systems," and with NFPA 90B, "Installation of Warm Air Heating and Air Conditioning Systems."

- B. Comply with AMCA 500-D testing for damper rating.

1.5 EXTRA MATERIALS

- A. Furnish extra materials that match products installed and that are packaged with protective covering for storage and identified with labels describing contents.
 - 1. Fusible Links: Furnish quantity equal to 10 percent of amount installed.

PART 2 - PRODUCTS

2.1 MATERIALS

- A. Comply with SMACNA's "HVAC Duct Construction Standards - Metal and Flexible" for acceptable materials, material thicknesses, and duct construction methods unless otherwise indicated. Sheet metal materials shall be free of pitting, seam marks, roller marks, stains, discolorations, and other imperfections.
- B. Galvanized Sheet Steel: Comply with ASTM A 653/A 653M.
 - 1. Galvanized Coating Designation: G90.
 - 2. Exposed-Surface Finish: Mill phosphatized.
- C. Stainless-Steel Sheets: Comply with ASTM A 480/A 480M, Type 304, and having a No. 2 finish for concealed ducts and finish for exposed ducts.
- D. Aluminum Sheets: Comply with ASTM B 209, Alloy 3003, Temper H14; with mill finish for concealed ducts and standard, 1-side bright finish for exposed ducts.
- E. Extruded Aluminum: Comply with ASTM B 221, Alloy 6063, Temper T6.
- F. Reinforcement Shapes and Plates: Galvanized-steel reinforcement where installed on galvanized sheet metal ducts; compatible materials for aluminum and stainless-steel ducts.
- G. Tie Rods: Galvanized steel, 1/4-inch minimum diameter for lengths 36 inches or less; 3/8-inch minimum diameter for lengths longer than 36 inches.

2.2 MANUAL VOLUME DAMPERS

- A. Standard, Steel, Manual Volume Dampers:
 - 1. Manufacturers: Subject to compliance with requirements, provide products by one of the following:
 - a. Air Balance Inc.; a division of Mestek, Inc.
 - b. American Warming and Ventilating; a division of Mestek, Inc.
 - c. Flexmaster U.S.A., Inc.
 - d. McGill AirFlow LLC.
 - e. METALAIRE, Inc.
 - f. Nailor Industries Inc.
 - g. Pottorff; a division of PCI Industries, Inc.
 - h. Ruskin Company.
 - i. Vent Products Company, Inc.
 - 2. Standard leakage rating, with linkage outside airstream.
 - 3. Suitable for horizontal or vertical applications.
 - 4. Frames:
 - a. Hat-shaped, galvanized-steel channels, 0.064-inch minimum thickness.
 - b. Mitered and welded corners.
 - c. Flanges for attaching to walls and flangeless frames for installing in ducts.
 - 5. Blades:

- a. Multiple or single blade.
 - b. Parallel- or opposed-blade design.
 - c. Stiffen damper blades for stability.
 - d. Galvanized-steel, 0.064 inch thick.
6. Blade Axles: Stainless steel.
7. Bearings:
- a. Stainless-steel sleeve.
 - b. Dampers in ducts with pressure classes of 3-inch wg or less shall have axles full length of damper blades and bearings at both ends of operating shaft.
8. Tie Bars and Brackets: Galvanized steel.
9. Provide with standoff bracket for actuator for externally insulated ducts.

2.3 FLANGE CONNECTORS

- A. Manufacturers: Subject to compliance with requirements, provide products by one of the following:
1. Ductmate Industries, Inc.
 2. Nexus PDQ; Division of Shilco Holdings Inc.
 3. Ward Industries, Inc.; a division of Hart & Cooley, Inc.
- B. Description: Add-on or roll-formed, factory-fabricated, slide-on transverse flange connectors, gaskets, and components.
- C. Material: Galvanized steel.
- D. Gage and Shape: Match connecting ductwork.

2.4 DUCT-MOUNTED ACCESS DOORS

- A. Manufacturers: Subject to compliance with requirements, provide products by one of the following:
1. American Warming and Ventilating; a division of Mestek, Inc.
 2. Cesco Products; a division of Mestek, Inc.
 3. Ductmate Industries, Inc.
 4. Flexmaster U.S.A., Inc.
 5. Greenheck Fan Corporation.
 6. McGill AirFlow LLC.
 7. Nailor Industries Inc.
 8. Pottorff; a division of PCI Industries, Inc.
 9. Ventfabrics, Inc.
 10. Ward Industries, Inc.; a division of Hart & Cooley, Inc.
- B. Duct-Mounted Access Doors: Fabricate access panels according to SMACNA's "HVAC Duct Construction Standards - Metal and Flexible"; Figures 2-10, "Duct Access Doors and Panels," and 2-11, "Access Panels - Round Duct."
1. Door:
 - a. Double wall, rectangular.
 - b. Galvanized sheet metal with insulation fill and thickness as indicated for duct pressure class.
 - c. Vision panel.
 - d. Hinges and Latches: 1-by-1-inch butt or piano hinge and cam latches.
 - e. Fabricate doors airtight and suitable for duct pressure class.
 2. Frame: Galvanized sheet steel, with bend-over tabs and foam gaskets.
 3. Number of Hinges and Locks:
 - a. Access Doors Less Than 12 Inches Square: No hinges and two sash locks.
 - b. Access Doors up to 18 Inches Square: Two hinges and two sash locks.
 - c. Access Doors up to 24 by 48 Inches: Three hinges and two compression latches.
 - d. Access Doors Larger Than 24 by 48 Inches: Four hinges and two compression latches with outside and inside handles.

- C. Pressure Relief Access Door:
 - 1. Door and Frame Material: Galvanized sheet steel.
 - 2. Door: Double wall with insulation fill with metal thickness applicable for duct pressure class.
 - 3. Operation: Open outward for positive-pressure ducts and inward for negative-pressure ducts.
 - 4. Factory set at 6-inch wg.
 - 5. Doors close when pressures are within set-point range.
 - 6. Hinge: Continuous piano.
 - 7. Latches: Cam.
 - 8. Seal: Neoprene or foam rubber.
 - 9. Insulation Fill: 1-inch- thick, fibrous-glass or polystyrene-foam board.

2.5 FLEXIBLE CONNECTORS

- A. Manufacturers: Subject to compliance with requirements, provide products by one of the following:
 - 1. Ductmate Industries, Inc.
 - 2. Duro Dyne Inc.
 - 3. Ventfabrics, Inc.
 - 4. Ward Industries, Inc.; a division of Hart & Cooley, Inc.
- B. Materials: Flame-retardant or noncombustible fabrics.
- C. Coatings and Adhesives: Comply with UL 181, Class 1.
- D. Metal-Edged Connectors: Factory fabricated with a fabric strip 5-3/4 inches wide attached to 2 strips of 2-3/4-inch- wide, 0.028-inch- thick, galvanized sheet steel or 0.032-inch- thick aluminum sheets. Provide metal compatible with connected ducts.
- E. Indoor System, Flexible Connector Fabric: Glass fabric double coated with neoprene.
 - 1. Minimum Weight: 26 oz./sq. yd..
 - 2. Tensile Strength: 480 lbf/inch in the warp and 360 lbf/inch in the filling.
 - 3. Service Temperature: Minus 40 to plus 200 deg F.
- F. Outdoor System, Flexible Connector Fabric: Glass fabric double coated with weatherproof, synthetic rubber resistant to UV rays and ozone.
 - 1. Minimum Weight: 24 oz./sq. yd..
 - 2. Minimum Tensile Strength: 500 lbf/inch in the warp and 440 lbf/inch in the filling.
 - 3. Service Temperature: Minus 50 to plus 250 deg F.
- G. Thrust Limits: Combination coil spring and elastomeric insert with spring and insert in compression, and with a load stop. Include rod and angle-iron brackets for attaching to fan discharge and duct.
 - 1. Frame: Steel, fabricated for connection to threaded rods and to allow for a maximum of 30 degrees of angular rod misalignment without binding or reducing isolation efficiency.
 - 2. Outdoor Spring Diameter: Not less than 80 percent of the compressed height of the spring at rated load.
 - 3. Minimum Additional Travel: 50 percent of the required deflection at rated load.
 - 4. Lateral Stiffness: More than 80 percent of rated vertical stiffness.
 - 5. Overload Capacity: Support 200 percent of rated load, fully compressed, without deformation or failure.
 - 6. Elastomeric Element: Molded, oil-resistant rubber or neoprene.
 - 7. Coil Spring: Factory set and field adjustable for a maximum of 1/4-inch movement at start and stop.

2.6 FLEXIBLE DUCTS

- A. Manufacturers:
 - 1. Flexmaster U.S.A., Inc.
 - 2. McGill AirFlow LLC.

3. Ward Industries, Inc.; a division of Hart & Cooley, Inc.
 4. Prior Approved Equal
- B. Insulated, Flexible Duct: UL 181, Class 1, aluminum laminate and polyester film with latex adhesive supported by helically wound, spring-steel wire; fibrous-glass insulation; aluminized vapor-barrier film.
1. Pressure Rating: 10-inch wg positive and 1.0-inch wg negative.
 2. Maximum Air Velocity: 4000 fpm.
 3. Temperature Range: Minus 20 to plus 210 deg F.
 4. Insulation R-value: Comply with ASHRAE/IESNA 90.1-2004.
- C. Flexible Duct Connectors:
1. Clamps: Stainless-steel band with cadmium-plated hex screw to tighten band with a worm-gear action in sizes 3 through 18 inches, to suit duct size.
 2. Non-Clamp Connectors: Adhesive plus tape.

2.7 DUCT ACCESSORY HARDWARE

- A. Instrument Test Holes: Cast iron or cast aluminum to suit duct material, including screw cap and gasket. Size to allow insertion of pitot tube and other testing instruments and of length to suit duct-insulation thickness.
- B. Adhesives: High strength, quick setting, neoprene based, waterproof, and resistant to gasoline and grease.

PART 3 - EXECUTION

3.1 INSTALLATION

- A. Install duct accessories according to applicable details in SMACNA's "HVAC Duct Construction Standards - Metal and Flexible" for metal ducts and in NAIMA AH116, "Fibrous Glass Duct Construction Standards," for fibrous-glass ducts.
- B. Install duct accessories of materials suited to duct materials; use galvanized-steel accessories in galvanized-steel and fibrous-glass ducts, stainless-steel accessories in stainless-steel ducts, and aluminum accessories in aluminum ducts.
- C. Install backdraft dampers at inlet of exhaust fans or exhaust ducts as close as possible to exhaust fan unless otherwise indicated.
- D. Install volume dampers at points on supply, return, and exhaust systems where branches extend from larger ducts. Where dampers are installed in ducts having duct liner, install dampers with hat channels of same depth as liner, and terminate liner with nosing at hat channel.
1. Install steel volume dampers in steel ducts.
 2. Install aluminum volume dampers in aluminum ducts.
- E. Set dampers to fully open position before testing, adjusting, and balancing.
- F. Install test holes at fan inlets and outlets and elsewhere as indicated.
- G. Install fire dampers according to UL listing.
- H. Connect ducts to duct silencers rigidly.
- I. Install duct access doors on sides of ducts to allow for inspecting, adjusting, and maintaining accessories and equipment at the following locations:

AIR DUCT ACCESSORIES

1. On both sides of duct coils.
2. Upstream from duct filters.
3. At outdoor-air intakes and mixed-air plenums.
4. Upstream from air flow measuring stations.
5. Adjacent to and close enough to fire or smoke dampers, to reset or reinstall fusible links. Access doors for access to fire or smoke dampers having fusible links shall be pressure relief access doors and shall be outward operation for access doors installed upstream from dampers and inward operation for access doors installed downstream from dampers.
6. Upstream and downstream from turning vanes.
7. Control devices requiring inspection.
8. Elsewhere as indicated.

J. Install access doors with swing against duct static pressure.

K. Access Door Sizes:

1. 18"x18" or as large as the duct will allow if duct is smaller.

L. Label access doors according to Division 23 Section "Identification for HVAC Piping and Equipment" to indicate the purpose of access door.

M. Install flexible connectors to connect ducts to air handling units.

N. For fans developing static pressures of 5-inch wg and more, cover flexible connectors with loaded vinyl sheet held in place with metal straps.

O. Connect shut-off terminal units to supply ducts directly on inlet and outlet.

P. Connect fan powered terminal units to upstream (medium pressure) supply ducts with maximum 12-inch lengths of flexible duct. Connect to discharge duct with flex duct connectors. Do not use flexible ducts to change directions.

Q. Connect diffusers to ducts with maximum 60-inch lengths of flexible duct clamped or strapped in place.

R. Connect flexible ducts to metal ducts with adhesive plus tape plus draw bands.

S. Install duct test holes where required for testing and balancing purposes.

T. Install thrust limits at centerline of thrust, symmetrical on both sides of equipment. Attach thrust limits at centerline of thrust and adjust to a maximum of 1/4-inch movement during start and stop of fans.

3.2 FIELD QUALITY CONTROL

A. Tests and Inspections:

1. Operate dampers to verify full range of movement.
2. Inspect locations of access doors and verify that purpose of access door can be performed.
3. Operate fire, smoke, and combination fire and smoke dampers to verify full range of movement and verify that proper heat-response device is installed.
4. Inspect turning vanes for proper and secure installation.
5. Operate remote damper operators to verify full range of movement of operator and damper.

END OF SECTION 233300

SECTION 23 3423 - HVAC POWER VENTILATORS

PART 1 - GENERAL

1.1 RELATED DOCUMENTS

- A. Drawings and general provisions of the Contract, including General and Supplementary Conditions and Division 01 Specification Sections, apply to this Section.

1.2 SUMMARY

- A. This Section includes the following:
 - 1. Ceiling-mounting ventilators.

1.3 PERFORMANCE REQUIREMENTS

- A. Project Altitude: Base fan-performance ratings on actual Project site elevations.
- B. Operating Limits: Classify according to AMCA 99.

1.4 SUBMITTALS

- A. Product Data: Include rated capacities, furnished specialties, and accessories for each type of product indicated and include the following:
 - 1. Certified fan performance curves with system operating conditions indicated.
 - 2. Certified fan sound-power ratings.
 - 3. Motor ratings and electrical characteristics, plus motor and electrical accessories.
 - 4. Material thickness and finishes, including color charts.
 - 5. Fan speed controllers.
- B. Shop Drawings: Detail equipment assemblies and indicate dimensions, weights, loads, required clearances, method of field assembly, components, and location and size of each field connection.
 - 1. Wiring Diagrams: Power, signal, and control wiring.
- C. Field quality-control test reports.
- D. Operation and Maintenance Data: For power ventilators to include in emergency, operation, and maintenance manuals.

1.5 QUALITY ASSURANCE

- A. Electrical Components, Devices, and Accessories: Listed and labeled as defined in NFPA 70, Article 100, by a testing agency acceptable to authorities having jurisdiction, and marked for intended use.
- B. AMCA Compliance: Products shall comply with performance requirements and shall be licensed to use the AMCA-Certified Ratings Seal.
- C. NEMA Compliance: Motors and electrical accessories shall comply with NEMA standards.
- D. UL Standard: Power ventilators shall comply with UL 705.

1.6 DELIVERY, STORAGE, AND HANDLING

- A. Deliver fans as factory-assembled unit, to the extent allowable by shipping limitations, with protective crating and covering.
- B. Disassemble and reassemble units, as required for moving to final location, according to manufacturer's written instructions.
- C. Lift and support units with manufacturer's designated lifting or supporting points.

1.7 COORDINATION

- A. Coordinate size and location of structural-steel support members.
- B. Coordinate size and location of concrete bases. Cast anchor-bolt inserts into bases. Concrete, reinforcement, and formwork requirements are specified in Division 03.
- C. Coordinate installation of roof curbs, equipment supports, and roof penetrations. These items are specified in Division 07 Section "Roof Accessories."

PART 2 - PRODUCTS

2.1 CEILING-MOUNTING VENTILATORS

- A. Manufacturers: Subject to compliance with requirements, provide products by one of the following:
 - 1. Twin City Fan Company
 - 2. Breidert Air Products.
 - 3. Carnes Company HVAC.
 - 4. Greenheck.
 - 5. Loren Cook Company.
 - 6. Penn-Barry
- B. Description: Centrifugal fans designed for installing in ceiling or wall or for concealed in-line applications.
- C. Housing: Steel, lined with acoustical insulation.
- D. Fan Wheel: Centrifugal wheels directly mounted on motor shaft. Fan shrouds, motor, and fan wheel shall be removable for service.
- E. Grille: Plastic or Aluminum, louvered grille with flange on intake and thumbscrew attachment to fan housing.
- F. Electrical Requirements: Junction box for electrical connection on housing and receptacle for motor plug-in.
- G. Accessories:
 - 1. Variable-Speed Controller: Solid-state control to reduce speed from 100 to less than 50 percent.

2.2 SOURCE QUALITY CONTROL

- A. Sound-Power Level Ratings: Comply with AMCA 301, "Methods for Calculating Fan Sound Ratings from Laboratory Test Data." Factory test fans according to AMCA 300, "Reverberant Room Method for Sound Testing of Fans." Label fans with the AMCA-Certified Ratings Seal.
- B. Fan Performance Ratings: Establish flow rate, pressure, power, air density, speed of rotation, and efficiency by factory tests and ratings according to AMCA 210, "Laboratory Methods of Testing Fans for Rating."

PART 3 - EXECUTION

3.1 INSTALLATION

- A. Install power ventilators level and plumb.
- B. Secure roof-mounting fans to roof curbs with cadmium-plated hardware. Refer to Division 07 Section "Roof Accessories" for installation of roof curbs.
- C. Ceiling Units: Suspend units from structure; use steel wire or metal straps.
- D. Support suspended units from structure using threaded steel rods and spring hangers having a static deflection of 1 inch.
- E. Install units with clearances for service and maintenance.
- F. Label units according to requirements specified in Division 23 Section "Identification for HVAC Piping and Equipment."

3.2 CONNECTIONS

- A. Duct installation and connection requirements are specified in other Division 23 Sections. Drawings indicate general arrangement of ducts and duct accessories. Make final duct connections with flexible connectors. Flexible connectors are specified in Division 23 Section "Air Duct Accessories."
- B. Install ducts adjacent to power ventilators to allow service and maintenance.
- C. Ground equipment according to Division 26 Section "Grounding and Bonding for Electrical Systems."
- D. Connect wiring according to Division 26 Section "Low-Voltage Electrical Power Conductors and Cables."

3.3 FIELD QUALITY CONTROL

- A. Perform the following field tests and inspections and prepare test reports:
 - 1. Verify that shipping, blocking, and bracing are removed.
 - 2. Verify that unit is secure on mountings and supporting devices and that connections to ducts and electrical components are complete. Verify that proper thermal-overload protection is installed in motors, starters, and disconnect switches.
 - 3. Verify that cleaning and adjusting are complete.
 - 4. Disconnect fan drive from motor, verify proper motor rotation direction, and verify fan wheel free rotation and smooth bearing operation. Reconnect fan drive system, align and adjust belts, and install belt guards.

5. Adjust belt tension.
6. Adjust damper linkages for proper damper operation.
7. Verify lubrication for bearings and other moving parts.
8. Verify that manual and automatic volume control and fire and smoke dampers in connected ductwork systems are in fully open position.
9. Disable automatic temperature-control operators, energize motor and adjust fan to indicated rpm, and measure and record motor voltage and amperage.
10. Shut unit down and reconnect automatic temperature-control operators.
11. Remove and replace malfunctioning units and retest as specified above.

- B. Test and adjust controls and safeties. Replace damaged and malfunctioning controls and equipment.

3.4 ADJUSTING

- A. Adjust damper linkages for proper damper operation.
- B. Refer to Division 23 Section "Testing, Adjusting, and Balancing for HVAC" for testing, adjusting, and balancing procedures.
- C. Lubricate bearings.

END OF SECTION 23 3423

SECTION 233713 - DIFFUSERS, REGISTERS, AND GRILLES

PART 1 - GENERAL

1.1 RELATED DOCUMENTS

- A. Drawings and general provisions of the Contract, including General and Supplementary Conditions and Division 01 Specification Sections, apply to this Section.

1.2 SUMMARY

- A. Section Includes:
 - 1. Rectangular and square ceiling diffusers.
 - 2. Louver face diffusers.
- B. Related Sections:
 - 1. Division 23 Section "Air Duct Accessories" for fire and smoke dampers and volume-control dampers not integral to diffusers, registers, and grilles.

1.3 SUBMITTALS

- A. Product Data: For each type of product indicated, include the following:
 - 1. Data Sheet: Indicate materials of construction, finish, and mounting details; and performance data including throw and drop, static-pressure drop, and noise ratings.
 - 2. Diffuser, Register, and Grille Schedule: Indicate drawing designation, room location, quantity, model number, size, and accessories furnished.
- B. Samples for Initial Selection: For diffusers, registers, and grilles with factory-applied color finishes.
- C. Samples for Verification: For diffusers, registers, and grilles, in manufacturer's standard sizes to verify color selected.
- D. Coordination Drawings: Reflected ceiling plans, drawn to scale, on which the following items are shown and coordinated with each other, using input from Installers of the items involved:
 - 1. Ceiling suspension assembly members.
 - 2. Method of attaching hangers to building structure.
 - 3. Size and location of initial access modules for acoustical tile.
 - 4. Ceiling-mounted items including lighting fixtures, diffusers, grilles, speakers, sprinklers, access panels, and special moldings.
 - 5. Duct access panels.
- E. Source quality-control reports.

PART 2 - PRODUCTS

2.1 CEILING DIFFUSERS

- A. Rectangular and Square Ceiling Diffusers:
 - 1. Manufacturers: Subject to compliance with requirements, provide products by one of the following:

- a. Carnes.
- b. Krueger.
- c. METALAIRE, Inc.
- d. Nailor Industries Inc.
- e. Price Industries.
- f. Titus.
- g. Tuttle & Bailey.
2. Devices shall be specifically designed for variable-air-volume flows.
3. Material: Steel.
4. Finish: Baked enamel, white.
5. Face Size: Refer to drawings
6. Mounting: Refer to Drawings.
7. Pattern: Fixed.

B. Louver Face Diffuser:

1. Manufacturers: Subject to compliance with requirements, provide products by one of the following:
 - a. Carnes.
 - b. METALAIRE, Inc.
 - c. Nailor Industries Inc.
 - d. Price Industries.
 - e. Titus.
 - f. Tuttle & Bailey.
2. Devices shall be specifically designed for variable-air-volume flows.
3. Material: Steel.
4. Finish: Baked enamel, white.
5. Face Size: Refer to Drawings
6. Mounting: Refer to Drawings.
7. Pattern: Four-way core style.

2.2 GRILLES

A. Fixed Face Grille:

1. Manufacturers: Subject to compliance with requirements, provide products by one of the following:
 - a. Carnes.
 - b. Krueger.
 - c. Metalaire
 - d. Nailor Industries Inc.
 - e. Price Industries.
 - f. Titus.
 - g. Tuttle & Bailey.
2. Material: Steel.
3. Finish: Baked enamel, white.
4. Frame: 1-1/4 inches wide.
5. Mounting: Refer to drawings

2.3 SOURCE QUALITY CONTROL

- A. Verification of Performance: Rate diffusers, registers, and grilles according to ASHRAE 70, "Method of Testing for Rating the Performance of Air Outlets and Inlets."

PART 3 - EXECUTION

3.1 EXAMINATION

- A. Examine areas where diffusers, registers, and grilles are to be installed for compliance with requirements for installation tolerances and other conditions affecting performance of equipment.
- B. Proceed with installation only after unsatisfactory conditions have been corrected.

3.2 INSTALLATION

- A. Install diffusers, registers, and grilles level and plumb.
- B. Ceiling-Mounted Outlets and Inlets: Drawings indicate general arrangement of ducts, fittings, and accessories. Air outlet and inlet locations have been indicated to achieve design requirements for air volume, noise criteria, airflow pattern, throw, and pressure drop. Make final locations where indicated, as much as practical. For units installed in lay-in ceiling panels, locate units in the center of panel. Where architectural features or other items conflict with installation, notify Architect for a determination of final location.
- C. Install diffusers, registers, and grilles with airtight connections to ducts and to allow service and maintenance of dampers, air extractors, and fire dampers.

3.3 ADJUSTING

- A. After installation, adjust diffusers, registers, and grilles to air patterns indicated, or as directed, before starting air balancing.

END OF SECTION 233713

SECTION 237313 - SPLIT-SYSTEM HEAT PUMP UNITS

PART 1 - GENERAL

1.1 RELATED DOCUMENTS

- A. Drawings and general provisions of the Contract, including General and Supplementary Conditions and Division 1 Specification Sections, apply to this Section.

1.2 SUMMARY

- A. This Section includes split-system air-conditioning and heat pump units consisting of separate evaporator-fan and compressor-condenser components. Units are designed for exposed or concealed mounting, and may be connected to ducts.

1.3 SUBMITTALS

- A. Product Data: Include rated capacities, furnished specialties, and accessories for each type of product indicated. Include performance data in terms of capacities, outlet velocities, static pressures, sound power characteristics, motor requirements, and electrical characteristics.
- B. Shop Drawings: Diagram power, signal, and control wiring.
- C. Samples for Initial Selection: For units with factory-applied color finishes.
- D. Field quality-control test reports.
- E. Operation and Maintenance Data: For split-system air-conditioning units to include in emergency, operation, and maintenance manuals.
- F. Warranty: Special warranty specified in this Section.

1.4 QUALITY ASSURANCE

- A. Product Options: Drawings indicate size, profiles, and dimensional requirements of split-system units and are based on the specific system indicated. Refer to Division 1 Section "Product Requirements."
- B. Electrical Components, Devices, and Accessories: Listed and labeled as defined in NFPA 70, Article 100, by a testing agency acceptable to authorities having jurisdiction, and marked for intended use.
- C. Energy-Efficiency Ratio: Equal to or greater than prescribed by ASHRAE 90.1, "Energy Efficient Design of New Buildings except Low-Rise Residential Buildings."
- D. Coefficient of Performance: Equal to or greater than prescribed by ASHRAE 90.1, "Energy Efficient Design of New Buildings except Low-Rise Residential Buildings."
- E. Units shall be designed to operate with HCFC-free refrigerants.

1.5 COORDINATION

- A. Coordinate size and location of concrete bases for units. Cast anchor-bolt inserts into bases. Concrete, reinforcement, and formwork are specified in Division 3 Section "Cast-in-Place Concrete."
- B. Coordinate size, location, and connection details with roof curbs, equipment supports, and roof penetrations specified in Division 7 Section "Roof Accessories."

1.6 WARRANTY

- A. Special Warranty: Manufacturer's standard form in which manufacturer agrees to repair or replace components of split-system air-conditioning units that fail in materials or workmanship within specified warranty period.
 - 1. Compressor Warranty Period: Five years from date of Substantial Completion.

1.7 EXTRA MATERIALS

- A. Furnish extra materials described below that match products installed and that are packaged with protective covering for storage and identified with labels describing contents.
 - 1. Filters: One set of filters for each unit.
 - 2. Fan Belts: One set of belts for each unit.

PART 2 - PRODUCTS

2.1 MANUFACTURERS

- A. Manufacturers: Subject to compliance with requirements, provide products by one of the following:
 - 1. Carrier Air Conditioning; Div. of Carrier Corporation.
 - 2. Lennox Industries Inc.
 - 3. Trane Company (The); Unitary Products Group.
 - 4. York International Corp.

2.2 CONCEALED EVAPORATOR-FAN COMPONENTS

- A. Chassis: Galvanized steel with flanged edges, removable panels for servicing, and insulation on back of panel.
 - 1. Insulation: Faced, glass-fiber duct liner.
 - 2. Drain Pans: Galvanized steel, with connection for drain; insulated.
- B. Refrigerant Coil: Copper tube, with mechanically bonded aluminum fins, complying with ARI 210/240, and with thermal-expansion valve.
- C. Electric Coil: Helical, nickel-chrome, resistance-wire heating elements with refractory ceramic support bushings; automatic-reset thermal cutout; built-in magnetic contactors; manual-reset thermal cutout; airflow proving device; and one-time fuses in terminal box for overcurrent protection.
- D. Fan: Forward-curved, double-width wheel of galvanized steel; directly connected to motor.
- E. Fan Motors: Comply with requirements in Division 15 Section "Motors."
 - 1. Special Motor Features: Multitapped, multispeed with internal thermal protection and permanent lubrication.
- F. Disposable Filters: **1 inch** thick, in fiberboard frames.

- G. Wiring Terminations: Connect motor to chassis wiring with plug connection.

2.3 HEAT PUMPS, AIR COOLED

- A. Manufacturers:
 - 1. Carrier Corporation; Carrier Air Conditioning Div.
 - 2. Lennox Industries Inc.
 - 3. Trane Co. (The); Worldwide Applied Systems Group.
 - 4. York International Corp.
- B. Description: Factory assembled and tested, air cooled; consisting of casing, compressors, condenser coils, condenser fans and motors, and unit controls.
- C. Compressor: Hermetically sealed with crankcase heater and mounted on vibration isolation. Compressor motor shall have thermal- and current-sensitive overload devices, start capacitor, relay, and contactor. Shall be provided with suction and discharge service valves.
 - 1. Compressor Type: Scroll.
 - 2. Refrigerant Charge: R-410A.
- D. Condenser Coil: Seamless copper-tube, aluminum-fin coil, including subcooling circuit and backseating liquid-line service access valve. Factory pressure test coils, then dehydrate by drawing a vacuum and fill with a holding charge of nitrogen or refrigerant.
- E. Condenser Fans: Propeller-type vertical discharge; either directly or belt driven. Include the following:
 - 1. Permanently lubricated ball-bearing motors.
 - 2. Separate motor for each fan.
 - 3. Dynamically and statically balanced fan assemblies.
- F. Operating and safety controls include the following:
 - 1. Manual-reset, high-pressure cutout switches.
 - 2. Automatic-reset, low-pressure cutout switches.
 - 3. Low oil pressure cutout switch.
 - 4. Compressor-winding thermostat cutout switch.
 - 5. Three-leg, compressor-overload protection.
 - 6. Control transformer.
 - 7. Magnetic contactors for compressor and condenser fan motors.
 - 8. Timer to prevent excessive compressor cycling.
- G. Heat Pump Components: Reversing valve and low-temperature air cut-off thermostat.
- H. Accessories:
 - 1. Electronic programmable thermostat, "Honeywell" Vision Pro 8000 to control heat pump unit and evaporator fan. Provide with remote sensor where specified on drawings.
 - 2. Low Ambient Controller: Cycles condenser fan to permit operation down to **0 deg F** with time-delay relay to bypass low-pressure switch.
 - 3. Refrigerant Line Kits: Soft-annealed copper suction and liquid lines factory cleaned, dried, pressurized, and sealed; factory-insulated suction line with flared fittings at both ends
- I. Unit Casings: Designed for outdoor installation with weather protection for components and controls and with removable panels for required access to compressors, controls, condenser fans, motors, and drives. Additional features include the following:
 - 1. Steel, galvanized or zinc coated, for exposed casing surfaces; treated and finished with manufacturer's standard paint coating.
 - 2. Perimeter base rail with forklift slots and lifting holes to facilitate rigging.
 - 3. Gasketed control panel door.
 - 4. Nonfused disconnect switch, factory mounted and wired, for single external electrical power connection.
 - 5. Condenser coil hail guard to protect coil from physical damage.

PART 3 - EXECUTION

3.1 INSTALLATION

- A. Install units level and plumb.
- B. Install evaporator-fan components using manufacturer's standard mounting devices securely fastened to building structure.
- C. Install ground-mounting, compressor-condenser components on **4-inch-** thick, reinforced concrete base; **4 inches** larger on each side than unit. Concrete, reinforcement, and formwork are specified in Division 3 Section "Cast-in-Place Concrete." Coordinate anchor installation with concrete base.
- D. Install ground-mounting, compressor-condenser components on polyethylene mounting base.
- E. Install roof-mounting compressor-condenser components on equipment supports specified in Division 7 Section "Roof Accessories." Anchor units to supports with removable, cadmium-plated fasteners.
- F. Install and connect precharged refrigerant tubing to component's quick-connect fittings. Install tubing to allow access to unit.

3.2 CONNECTIONS

- A. Duct Connections: Duct installation requirements are specified in Division 15 Section "Metal Ducts." Drawings indicate the general arrangement of ducts. Connect supply and return ducts to split-system air-conditioning units with flexible duct connectors. Flexible duct connectors are specified in Division 15 Section "Duct Accessories."
- B. Ground equipment according to Division 16 Section "Grounding and Bonding."
- C. Electrical Connections: Comply with requirements in Division 16 Sections for power wiring, switches, and motor controls.

3.3 FIELD QUALITY CONTROL

- A. Manufacturer's Field Service: Engage a factory-authorized service representative to inspect, test, and adjust field-assembled components and equipment installation, including connections, and to assist in field testing. Report results in writing.
- B. Perform the following field tests and inspections and prepare test reports:
 - 1. Leak Test: After installation, charge system and test for leaks. Repair leaks and retest until no leaks exist.
 - 2. Operational Test: After electrical circuitry has been energized, start units to confirm proper motor rotation and unit operation.
 - 3. Test and adjust controls and safeties. Replace damaged and malfunctioning controls and equipment.
- C. Remove and replace malfunctioning units and retest as specified above.

3.4 STARTUP SERVICE

- A. Engage a factory-authorized service representative to perform startup service.
 - 1. Complete installation and startup checks according to manufacturer's written instructions.

3.5 DEMONSTRATION

- A. Engage a factory-authorized service representative to train Owner's maintenance personnel to adjust, operate, and maintain units. Refer to Division 1 Section "Closeout Procedures Demonstration and Training."

END OF SECTION 237313

SECTION 260500 - COMMON WORK RESULTS FOR ELECTRICAL

PART 1 - GENERAL

1.1 RELATED DOCUMENTS

- A. Drawings and general provisions of the Contract, including General and Supplementary Conditions and Division 01 Specification Sections, apply to this Section.

1.2 SUMMARY

- A. Section Includes:
 - 1. Electrical equipment coordination and installation.
 - 2. Sleeves for raceways and cables.
 - 3. Sleeve seals.
 - 4. Grout.
 - 5. Common electrical installation requirements.

1.3 DEFINITIONS

- A. EPDM: Ethylene-propylene-diene terpolymer rubber.
- B. NBR: Acrylonitrile-butadiene rubber.

1.4 SUBMITTALS

- A. Product Data: For sleeve seals.

1.5 COORDINATION

- A. Coordinate arrangement, mounting, and support of electrical equipment:
 - 1. To allow maximum possible headroom unless specific mounting heights that reduce headroom are indicated.
 - 2. To provide for ease of disconnecting the equipment with minimum interference to other installations.
 - 3. To allow right of way for piping and conduit installed at required slope.
 - 4. So connecting raceways, cables, wireways, cable trays, and busways will be clear of obstructions and of the working and access space of other equipment.
- B. Coordinate installation of required supporting devices and set sleeves in cast-in-place concrete, masonry walls, and other structural components as they are constructed.
- C. Coordinate sleeve selection and application with selection and application of firestopping specified in Division 07 Section "Penetration Firestopping."

PART 2 - PRODUCTS

2.1 SLEEVES FOR RACEWAYS AND CABLES

- A. Steel Pipe Sleeves: ASTM A 53/A 53M, Type E, Grade B, Schedule 40, galvanized steel, plain ends.
- B. Cast-Iron Pipe Sleeves: Cast or fabricated "wall pipe," equivalent to ductile-iron pressure pipe, with plain ends and integral waterstop, unless otherwise indicated.
- C. Sleeves for Rectangular Openings: Galvanized sheet steel.
 - 1. Minimum Metal Thickness:
 - a. For sleeve cross-section rectangle perimeter less than 50 inches (1270 mm) and no side more than 16 inches (400 mm), thickness shall be 0.052 inch (1.3 mm).
 - b. For sleeve cross-section rectangle perimeter equal to, or more than, 50 inches (1270 mm) and 1 or more sides equal to, or more than, 16 inches (400 mm), thickness shall be 0.138 inch (3.5 mm).

2.2 SLEEVE SEALS

- A. Description: Modular sealing device, designed for field assembly, to fill annular space between sleeve and raceway or cable.
 - 1. Manufacturers: Subject to compliance with requirements, available manufacturers offering products that may be incorporated into the Work include, but are not limited to, the following:
 - a. Advance Products & Systems, Inc.
 - b. Calpico, Inc.
 - c. Metraflex Co.
 - d. Pipeline Seal and Insulator, Inc.
 - 2. Sealing Elements: EPDM interlocking links shaped to fit surface of cable or conduit. Include type and number required for material and size of raceway or cable.
 - 3. Pressure Plates: Carbon steel. Include two for each sealing element.
 - 4. Connecting Bolts and Nuts: Carbon steel with corrosion-resistant coating of length required to secure pressure plates to sealing elements. Include one for each sealing element.

2.3 GROUT

- A. Nonmetallic, Shrinkage-Resistant Grout: ASTM C 1107, factory-packaged, nonmetallic aggregate grout, noncorrosive, nonstaining, mixed with water to consistency suitable for application and a 30-minute working time.

PART 3 - EXECUTION

3.1 COMMON REQUIREMENTS FOR ELECTRICAL INSTALLATION

- A. Comply with NECA 1.
- B. Measure indicated mounting heights to bottom of unit for suspended items and to center of unit for wall-mounting items.

- C. Headroom Maintenance: If mounting heights or other location criteria are not indicated, arrange and install components and equipment to provide maximum possible headroom consistent with these requirements.
- D. Equipment: Install to facilitate service, maintenance, and repair or replacement of components of both electrical equipment and other nearby installations. Connect in such a way as to facilitate future disconnecting with minimum interference with other items in the vicinity.
- E. Right of Way: Give to piping systems installed at a required slope.

3.2 SLEEVE INSTALLATION FOR ELECTRICAL PENETRATIONS

- A. Electrical penetrations occur when raceways, cables, wireways, cable trays, or busways penetrate concrete slabs, concrete or masonry walls, or fire-rated floor and wall assemblies.
- B. Concrete Slabs and Walls: Install sleeves for penetrations unless core-drilled holes or formed openings are used. Install sleeves during erection of slabs and walls.
- C. Use pipe sleeves unless penetration arrangement requires rectangular sleeved opening.
- D. Fire-Rated Assemblies: Install sleeves for penetrations of fire-rated floor and wall assemblies unless openings compatible with firestop system used are fabricated during construction of floor or wall.
- E. Cut sleeves to length for mounting flush with both surfaces of walls.
- F. Extend sleeves installed in floors 2 inches (50 mm) above finished floor level.
- G. Size pipe sleeves to provide 1/4-inch (6.4-mm) annular clear space between sleeve and raceway or cable, unless indicated otherwise.
- H. Seal space outside of sleeves with grout for penetrations of concrete and masonry
 - 1. Promptly pack grout solidly between sleeve and wall so no voids remain. Tool exposed surfaces smooth; protect grout while curing.
- I. Interior Penetrations of Non-Fire-Rated Walls and Floors: Seal annular space between sleeve and raceway or cable, using joint sealant appropriate for size, depth, and location of joint. Comply with requirements in Division 07 Section "Joint Sealants."
- J. Fire-Rated-Assembly Penetrations: Maintain indicated fire rating of walls, partitions, ceilings, and floors at raceway and cable penetrations. Install sleeves and seal raceway and cable penetration sleeves with firestop materials. Comply with requirements in Division 07 Section "Penetration Firestopping."
- K. Roof-Penetration Sleeves: Seal penetration of individual raceways and cables with flexible boot-type flashing units applied in coordination with roofing work.
- L. Aboveground, Exterior-Wall Penetrations: Seal penetrations using steel pipe sleeves and mechanical sleeve seals. Select sleeve size to allow for 1-inch (25-mm) annular clear space between pipe and sleeve for installing mechanical sleeve seals.
- M. Underground, Exterior-Wall Penetrations: Install cast-iron pipe sleeves. Size sleeves to allow for 1-inch (25-mm) annular clear space between raceway or cable and sleeve for installing mechanical sleeve seals.

3.3 SLEEVE-SEAL INSTALLATION

- A. Install to seal exterior wall penetrations.

- B. Use type and number of sealing elements recommended by manufacturer for raceway or cable material and size. Position raceway or cable in center of sleeve. Assemble mechanical sleeve seals and install in annular space between raceway or cable and sleeve. Tighten bolts against pressure plates that cause sealing elements to expand and make watertight seal.

3.4 FIRESTOPPING

- A. Apply firestopping to penetrations of fire-rated floor and wall assemblies for electrical installations to restore original fire-resistance rating of assembly. Firestopping materials and installation requirements are specified in Division 07 Section "Penetration Firestopping."

END OF SECTION 260500

SECTION 260519 - LOW-VOLTAGE ELECTRICAL POWER CONDUCTORS AND CABLES

PART 1 - GENERAL

1.1 RELATED DOCUMENTS

- A. Drawings and general provisions of the Contract, including General and Supplementary Conditions and Division 01 Specification Sections, apply to this Section.

1.2 SUMMARY

- A. This Section includes the following:
 - 1. Building wires and cables rated 600 V and less.
 - 2. Connectors, splices, and terminations rated 600 V and less.
 - 3. Sleeves and sleeve seals for cables.

1.3 DEFINITIONS

- A. EPDM: Ethylene-propylene-diene terpolymer rubber.
- B. NBR: Acrylonitrile-butadiene rubber.

1.4 SUBMITTALS

- A. Product Data: For each type of product indicated.
- B. Qualification Data: For testing agency.
- C. Field quality-control test reports.

1.5 QUALITY ASSURANCE

- A. Testing Agency Qualifications: An independent agency, with the experience and capability to conduct the testing indicated, that is a member company of the InterNational Electrical Testing Association or is a nationally recognized testing laboratory (NRTL) as defined by OSHA in 29 CFR 1910.7, and that is acceptable to authorities having jurisdiction.
 - 1. Testing Agency's Field Supervisor: Person currently certified by the InterNational Electrical Testing Association or the National Institute for Certification in Engineering Technologies to supervise on-site testing specified in Part 3.
- B. Electrical Components, Devices, and Accessories: Listed and labeled as defined in NFPA 70, Article 100, by a testing agency acceptable to authorities having jurisdiction, and marked for intended use.
- C. Comply with NFPA 70.

1.6 COORDINATION

- A. Set sleeves in cast-in-place concrete, masonry walls, and other structural components as they are constructed.

PART 2 - PRODUCTS

2.1 CONDUCTORS AND CABLES

- A. Available Manufacturers: Subject to compliance with requirements, manufacturers offering products that may be incorporated into the Work include, but are not limited to, the following:
- B. Manufacturers: Subject to compliance with requirements, provide products by one of the following:
 - 1. Alcan Products Corporation; Alcan Cable Division.
 - 2. American Insulated Wire Corp.; a Leviton Company.
 - 3. General Cable Corporation.
 - 4. Senator Wire & Cable Company.
 - 5. Southwire Company.
- C. Copper Conductors: Comply with NEMA WC 70.
- D. Conductor Insulation: Comply with NEMA WC 70 for Types THW, THHN-THWN, and XHHW.

2.2 CONNECTORS AND SPLICES

- A. Available Manufacturers: Subject to compliance with requirements, manufacturers offering products that may be incorporated into the Work include, but are not limited to, the following:
- B. Manufacturers: Subject to compliance with requirements, provide products by one of the following:
 - 1. AFC Cable Systems, Inc.
 - 2. Hubbell Power Systems, Inc.
 - 3. O-Z/Gedney; EGS Electrical Group LLC.
 - 4. 3M; Electrical Products Division.
 - 5. Tyco Electronics Corp.
- C. Description: Factory-fabricated connectors and splices of size, ampacity rating, material, type, and class for application and service indicated.

2.3 SLEEVES FOR CABLES

- A. Steel Pipe Sleeves: ASTM A 53/A 53M, Type E, Grade B, Schedule 40, galvanized steel, plain ends.
- B. Cast-Iron Pipe Sleeves: Cast or fabricated "wall pipe," equivalent to ductile-iron pressure pipe, with plain ends and integral waterstop, unless otherwise indicated.
- C. Sleeves for Rectangular Openings: Galvanized sheet steel with minimum 0.052- or 0.138-inch (1.3- or 3.5-mm) thickness as indicated and of length to suit application.
- D. Coordinate sleeve selection and application with selection and application of firestopping specified in Division 07 Section "Penetration Firestopping."

2.4 SLEEVE SEALS

- A. Available Manufacturers: Subject to compliance with requirements, manufacturers offering products that may be incorporated into the Work include, but are not limited to, the following:
- B. Manufacturers: Subject to compliance with requirements, provide products by one of the following:
- C. Basis-of-Design Product: Subject to compliance with requirements, provide the product indicated on Drawings or a comparable product by one of the following:
 - 1. Advance Products & Systems, Inc.
 - 2. Calpico, Inc.
 - 3. Metraflex Co.
 - 4. Pipeline Seal and Insulator, Inc.
- D. Description: Modular sealing device, designed for field assembly, to fill annular space between sleeve and cable.
 - 1. Sealing Elements: NBR interlocking links shaped to fit surface of cable or conduit. Include type and number required for material and size of raceway or cable.
 - 2. Pressure Plates: Carbon steel. Include two for each sealing element.
 - 3. Connecting Bolts and Nuts: Carbon steel with corrosion-resistant coating of length required to secure pressure plates to sealing elements. Include one for each sealing element.

PART 3 - EXECUTION

3.1 CONDUCTOR MATERIAL APPLICATIONS

- A. Feeders: Copper. Solid for No. 10 AWG and smaller; stranded for No. 8 AWG and larger.
- B. Branch Circuits: Copper. Solid for No. 10 AWG and smaller; stranded for No. 8 AWG and larger.

3.2 CONDUCTOR INSULATION AND MULTICONDUCTOR CABLE APPLICATIONS AND WIRING METHODS

- A. Service Entrance: Type THHN-THWN, single conductors in raceway.
- B. Exposed Feeders: Type THHN-THWN, single conductors in raceway.
- C. Feeders Concealed in Ceilings, Walls, Partitions, and Crawlspace: Type THHN-THWN, single conductors in raceway.
- D. Feeders Concealed in Concrete, below Slabs-on-Grade, and Underground: Type THHN-THWN, single conductors in raceway.
- E. Branch Circuits Concealed in Ceilings, Walls, and Partitions: Type THHN-THWN, single conductors in raceway.
- F. Branch Circuits Concealed in Concrete, below Slabs-on-Grade, and Underground: Type THHN-THWN, single conductors in raceway.
- G. Cord Drops and Portable Appliance Connections: Type SO, hard service cord with stainless-steel, wire-mesh, strain relief device at terminations to suit application.
- H. Class 1 Control Circuits: Type THHN-THWN, in raceway.

- I. Class 2 Control Circuits: Type THHN-THWN, in raceway.

3.3 INSTALLATION OF CONDUCTORS AND CABLES

- A. Conceal cables in finished walls, ceilings, and floors, unless otherwise indicated.
- B. Use manufacturer-approved pulling compound or lubricant where necessary; compound used must not deteriorate conductor or insulation. Do not exceed manufacturer's recommended maximum pulling tensions and sidewall pressure values.
- C. Use pulling means, including fish tape, cable, rope, and basket-weave wire/cable grips, that will not damage cables or raceway.
- D. Install exposed cables parallel and perpendicular to surfaces of exposed structural members, and follow surface contours where possible.
- E. Support cables according to Division 26 Section "Hangers and Supports for Electrical Systems."
- F. Identify and color-code conductors and cables according to Division 26 Section "Identification for Electrical Systems."

3.4 CONNECTIONS

- A. Tighten electrical connectors and terminals according to manufacturer's published torque-tightening values. If manufacturer's torque values are not indicated, use those specified in UL 486A and UL 486B.
- B. Make splices and taps that are compatible with conductor material and that possess equivalent or better mechanical strength and insulation ratings than unspliced conductors.
 - 1. Use oxide inhibitor in each splice and tap conductor for aluminum conductors.
- C. Wiring at Outlets: Install conductor at each outlet, with at least 12 inches (300 mm) of slack.

3.5 SLEEVE INSTALLATION FOR ELECTRICAL PENETRATIONS

- A. Coordinate sleeve selection and application with selection and application of firestopping specified in Division 07 Section "Penetration Firestopping."
- B. Concrete Slabs and Walls: Install sleeves for penetrations unless core-drilled holes or formed openings are used. Install sleeves during erection of slabs and walls.
- C. Use pipe sleeves unless penetration arrangement requires rectangular sleeved opening.
- D. Rectangular Sleeve Minimum Metal Thickness:
 - 1. For sleeve rectangle perimeter less than 50 inches (1270 mm) and no side greater than 16 inches (400 mm), thickness shall be 0.052 inch (1.3 mm).
 - 2. For sleeve rectangle perimeter equal to, or greater than, 50 inches (1270 mm) and 1 or more sides equal to, or greater than, 16 inches (400 mm), thickness shall be 0.138 inch (3.5 mm).
- E. Fire-Rated Assemblies: Install sleeves for penetrations of fire-rated floor and wall assemblies unless openings compatible with firestop system used are fabricated during construction of floor or wall.
- F. Cut sleeves to length for mounting flush with both wall surfaces.

- G. Extend sleeves installed in floors 2 inches (50 mm) above finished floor level.
- H. Size pipe sleeves to provide 1/4-inch (6.4-mm) annular clear space between sleeve and cable unless sleeve seal is to be installed or unless seismic criteria require different clearance.
- I. Seal space outside of sleeves with grout for penetrations of concrete and masonry and with approved joint compound for gypsum board assemblies.
- J. Interior Penetrations of Non-Fire-Rated Walls and Floors: Seal annular space between sleeve and cable, using joint sealant appropriate for size, depth, and location of joint according to Division 07 Section "Joint Sealants."
- K. Fire-Rated-Assembly Penetrations: Maintain indicated fire rating of walls, partitions, ceilings, and floors at cable penetrations. Install sleeves and seal with firestop materials according to Division 07 Section "Penetration Firestopping."
- L. Roof-Penetration Sleeves: Seal penetration of individual cables with flexible boot-type flashing units applied in coordination with roofing work.
- M. Aboveground Exterior-Wall Penetrations: Seal penetrations using sleeves and mechanical sleeve seals. Size sleeves to allow for 1-inch (25-mm) annular clear space between pipe and sleeve for installing mechanical sleeve seals.
- N. Underground Exterior-Wall Penetrations: Install cast-iron "wall pipes" for sleeves. Size sleeves to allow for 1-inch (25-mm) annular clear space between cable and sleeve for installing mechanical sleeve seals.

3.6 SLEEVE-SEAL INSTALLATION

- A. Install to seal underground exterior-wall penetrations.
- B. Use type and number of sealing elements recommended by manufacturer for cable material and size. Position cable in center of sleeve. Assemble mechanical sleeve seals and install in annular space between cable and sleeve. Tighten bolts against pressure plates that cause sealing elements to expand and make watertight seal.

3.7 FIRESTOPPING

- A. Apply firestopping to electrical penetrations of fire-rated floor and wall assemblies to restore original fire-resistance rating of assembly according to Division 07 Section "Penetration Firestopping."

3.8 FIELD QUALITY CONTROL

- A. Testing Agency: Engage a qualified testing agency to perform tests and inspections and prepare test reports.
- B. Perform tests and inspections and prepare test reports.
- C. Tests and Inspections:
 - 1. After installing conductors and cables and before electrical circuitry has been energized, test service entrance and feeder conductors for compliance with requirements.
 - 2. Perform each visual and mechanical inspection and electrical test stated in NETA Acceptance Testing Specification. Certify compliance with test parameters.

3. Infrared Scanning: After Substantial Completion, but not more than 60 days after Final Acceptance, perform an infrared scan of each splice in cables and conductors No. 3 AWG and larger. Remove box and equipment covers so splices are accessible to portable scanner.
 - a. Follow-up Infrared Scanning: Perform an additional follow-up infrared scan of each splice 11 months after date of Substantial Completion.
 - b. Instrument: Use an infrared scanning device designed to measure temperature or to detect significant deviations from normal values. Provide calibration record for device.
 - c. Record of Infrared Scanning: Prepare a certified report that identifies splices checked and that describes scanning results. Include notation of deficiencies detected, remedial action taken, and observations after remedial action.

- D. Test Reports: Prepare a written report to record the following:
 1. Test procedures used.
 2. Test results that comply with requirements.
 3. Test results that do not comply with requirements and corrective action taken to achieve compliance with requirements.

- E. Remove and replace malfunctioning units and retest as specified above.

END OF SECTION 260519

SECTION 260526 - GROUNDING AND BONDING FOR ELECTRICAL SYSTEMS

PART 1 - GENERAL

1.1 RELATED DOCUMENTS

- A. Drawings and general provisions of the Contract, including General and Supplementary Conditions and Division 01 Specification Sections, apply to this Section.

1.2 SUMMARY

- A. This Section includes methods and materials for grounding systems and equipment, plus the following special applications:
 - 1. Underground distribution grounding.

1.3 SUBMITTALS

- A. Product Data: For each type of product indicated.
- B. Other Informational Submittals: Plans showing dimensioned as-built locations of grounding features specified in Part 3 "Field Quality Control" Article, including the following:
 - 1. Ground rods.
 - 2. Grounding arrangements and connections for separately derived systems.
 - 3. Grounding for sensitive electronic equipment.
- C. Qualification Data: For testing agency and testing agency's field supervisor.
- D. Field quality-control test reports.
- E. Operation and Maintenance Data: For grounding to include the following in emergency, operation, and maintenance manuals:
 - 1. Instructions for periodic testing and inspection of grounding features at test wells, grounding connections for separately derived systems, based on NFPA 70B .
 - a. Tests shall be to determine if ground resistance or impedance values remain within specified maximums, and instructions shall recommend corrective action if they do not.
 - b. Include recommended testing intervals.

1.4 QUALITY ASSURANCE

- A. Electrical Components, Devices, and Accessories: Listed and labeled as defined in NFPA 70, Article 100, by a testing agency acceptable to authorities having jurisdiction, and marked for intended use.
- B. Comply with UL 467 for grounding and bonding materials and equipment.

2.1 CONDUCTORS

- A. Insulated Conductors: Copper wire or cable insulated for 600 V unless otherwise required by applicable Code or authorities having jurisdiction.
- B. Bare Copper Conductors:
 - 1. Solid Conductors: ASTM B 3.
 - 2. Stranded Conductors: ASTM B 8.
 - 3. Bonding Cable: 28 kcmil, 14 strands of No. 17 AWG conductor, 1/4 inch (6 mm) in diameter.
 - 4. Bonding Conductor: No. 4 or No. 6 AWG, stranded conductor.
 - 5. Bonding Jumper: Copper tape, braided conductors, terminated with copper ferrules; 1-5/8 inches (41 mm) wide and 1/16 inch (1.6 mm) thick.
- C. Grounding Bus: Rectangular bars of annealed copper, 1/4 by 2 inches in cross section, unless otherwise indicated; with insulators.

2.2 CONNECTORS

- A. Listed and labeled by a nationally recognized testing laboratory acceptable to authorities having jurisdiction for applications in which used, and for specific types, sizes, and combinations of conductors and other items connected.
- B. Bolted Connectors for Conductors and Pipes: Copper or copper alloy, bolted pressure-type, with at least two bolts.
 - 1. Pipe Connectors: Clamp type, sized for pipe.
- C. Welded Connectors: Exothermic-welding kits of types recommended by kit manufacturer for materials being joined and installation conditions.

2.3 GROUNDING ELECTRODES

- A. Ground Rods: Copper-clad steel; 3/4 inch by 10 feet (19 mm by 3 m) in diameter.

PART 3 - EXECUTION

3.1 APPLICATIONS

- A. Conductors: Install solid conductor for No. 10 AWG and smaller, and stranded conductors for No. 8 AWG and larger, unless otherwise indicated.
- B. Underground Grounding Conductors: Install bare copper conductor, No. 3/0 AWG minimum.
 - 1. Bury at least 24 inches (600 mm) below grade.
- C. Isolated Grounding Conductors: Green-colored insulation with continuous yellow stripe. On feeders with isolated ground, identify grounding conductor where visible to normal inspection, with alternating bands of green and yellow tape, with at least three bands of green and two bands of yellow.
- D. Grounding Bus: Install in electrical and telephone equipment rooms, in rooms housing service equipment, and elsewhere as indicated.

1. Install bus on insulated spacers 1 inch (25 mm), minimum, from wall 6 inches (150 mm) above finished floor, unless otherwise indicated.
2. Where indicated on both sides of doorways, route bus up to top of door frame, across top of doorway, down to specified height above floor, and connect to horizontal bus.

E. Conductor Terminations and Connections:

1. Pipe and Equipment Grounding Conductor Terminations: Bolted connectors.
2. Underground Connections: Welded connectors, except at test wells and as otherwise indicated.
3. Connections to Ground Rods at Test Wells: Bolted connectors.
4. Connections to Structural Steel: Welded connectors.

3.2 GROUNDING UNDERGROUND DISTRIBUTION SYSTEM COMPONENTS

- A. Comply with IEEE C2 grounding requirements.
- B. Grounding Manholes and Handholes: Install a driven ground rod through manhole or handhole floor, close to wall, and set rod depth so 4 inches (100 mm) will extend above finished floor. If necessary, install ground rod before manhole is placed and provide No. 1/0 AWG bare, tinned-copper conductor from ground rod into manhole through a waterproof sleeve in manhole wall. Protect ground rods passing through concrete floor with a double wrapping of pressure-sensitive insulating tape or heat-shrunk insulating sleeve from 2 inches (50 mm) above to 6 inches (150 mm) below concrete. Seal floor opening with waterproof, nonshrink grout.
- C. Grounding Connections to Manhole Components: Bond exposed-metal parts such as inserts, cable racks, pulling irons, ladders, and cable shields within each manhole or handhole, to ground rod or grounding conductor. Make connections with No. 4 AWG minimum, stranded, hard-drawn copper bonding conductor. Train conductors level or plumb around corners and fasten to manhole walls. Connect to cable armor and cable shields as recommended by manufacturer of splicing and termination kits.

3.3 EQUIPMENT GROUNDING

- A. Install insulated equipment grounding conductors with all feeders and branch circuits.
- B. Install insulated equipment grounding conductors with the following items, in addition to those required by NFPA 70:
1. Feeders and branch circuits.
 2. Lighting circuits.
 3. Receptacle circuits.
 4. Single-phase motor and appliance branch circuits.
 5. Three-phase motor and appliance branch circuits.
 6. Flexible raceway runs.
 7. Computer and Rack-Mounted Electronic Equipment Circuits: Install insulated equipment grounding conductor in branch-circuit runs from equipment-area power panels and power-distribution units.
- C. Air-Duct Equipment Circuits: Install insulated equipment grounding conductor to duct-mounted electrical devices operating at 120 V and more, including air cleaners, heaters, dampers, humidifiers, and other duct electrical equipment. Bond conductor to each unit and to air duct and connected metallic piping.
- D. Water Heater, Heat-Tracing, and Antifrost Heating Cables: Install a separate insulated equipment grounding conductor to each electric water heater and heat-tracing cable. Bond conductor to heater units, piping, connected equipment, and components.
- E. Signal and Communication Equipment: For telephone, alarm, voice and data, and other communication equipment, provide No. 4 AWG minimum insulated grounding conductor in raceway from grounding electrode system to each service location, terminal cabinet, wiring closet, and central equipment location.

1. Service and Central Equipment Locations and Wiring Closets: Terminate grounding conductor on a 1/4-by-2-by-12-inch (6-by-50-by-300-mm) grounding bus.
2. Terminal Cabinets: Terminate grounding conductor on cabinet grounding terminal.

- F. Metal Poles Supporting Outdoor Lighting Fixtures: Install grounding electrode and a separate insulated equipment grounding conductor in addition to grounding conductor installed with branch-circuit conductors.

3.4 INSTALLATION

- A. Grounding Conductors: Route along shortest and straightest paths possible, unless otherwise indicated or required by Code. Avoid obstructing access or placing conductors where they may be subjected to strain, impact, or damage.

- B. Ground Rods: Drive rods until tops are 2 inches (50 mm) below finished floor or final grade, unless otherwise indicated.

1. Interconnect ground rods with grounding electrode conductor below grade and as otherwise indicated. Make connections without exposing steel or damaging coating, if any.
2. For grounding electrode system, install at least three rods spaced at least one-rod length from each other and located at least the same distance from other grounding electrodes, and connect to the service grounding electrode conductor.

- C. Bonding Straps and Jumpers: Install in locations accessible for inspection and maintenance, except where routed through short lengths of conduit.

1. Bonding to Structure: Bond straps directly to basic structure, taking care not to penetrate any adjacent parts.
2. Bonding to Equipment Mounted on Vibration Isolation Hangers and Supports: Install so vibration is not transmitted to rigidly mounted equipment.
3. Use exothermic-welded connectors for outdoor locations, but if a disconnect-type connection is required, use a bolted clamp.

- D. Grounding and Bonding for Piping:

1. Metal Water Service Pipe: Install insulated copper grounding conductors, in conduit, from building's main service equipment, or grounding bus, to main metal water service entrances to building. Connect grounding conductors to main metal water service pipes, using a bolted clamp connector or by bolting a lug-type connector to a pipe flange, using one of the lug bolts of the flange. Where a dielectric main water fitting is installed, connect grounding conductor on street side of fitting. Bond metal grounding conductor conduit or sleeve to conductor at each end.
2. Water Meter Piping: Use braided-type bonding jumpers to electrically bypass water meters. Connect to pipe with a bolted connector.
3. Bond each aboveground portion of gas piping system downstream from equipment shutoff valve.

- E. Bonding Interior Metal Ducts: Bond metal air ducts to equipment grounding conductors of associated fans, blowers, electric heaters, and air cleaners. Install bonding jumper to bond across flexible duct connections to achieve continuity.

- F. Grounding for Steel Building Structure: Install a driven ground rod at base of each corner column and at intermediate exterior columns at distances not more than 60 feet (18 m) apart.

3.5 FIELD QUALITY CONTROL

- A. Perform the following tests and inspections and prepare test reports:

1. After installing grounding system but before permanent electrical circuits have been energized, test for compliance with requirements.

2. Test completed grounding system at each location where a maximum ground-resistance level is specified, at service disconnect enclosure grounding terminal, at ground test wells, and at individual ground rods. Make tests at ground rods before any conductors are connected.
 - a. Measure ground resistance not less than two full days after last trace of precipitation and without soil being moistened by any means other than natural drainage or seepage and without chemical treatment or other artificial means of reducing natural ground resistance.
 - b. Perform tests by fall-of-potential method according to IEEE 81.
 3. Prepare dimensioned drawings locating each test well, ground rod and ground rod assembly, and other grounding electrodes. Identify each by letter in alphabetical order, and key to the record of tests and observations. Include the number of rods driven and their depth at each location, and include observations of weather and other phenomena that may affect test results. Describe measures taken to improve test results.
- B. Report measured ground resistances that exceed the following values:
1. Power and Lighting Equipment or System with Capacity 500 kVA and Less: 10 ohms.
 2. Power and Lighting Equipment or System with Capacity 500 to 1000 kVA: 5 ohms.
 3. Power Distribution Units or Panelboards Serving Electronic Equipment: 1 ohm.
 4. Pad-Mounted Equipment: 5 ohms.
 5. Manhole Grounds: 10 ohms.
- C. Excessive Ground Resistance: If resistance to ground exceeds specified values, notify Architect promptly and include recommendations to reduce ground resistance.

END OF SECTION 260526

SECTION 260529 - HANGERS AND SUPPORTS FOR ELECTRICAL SYSTEMS

PART 1 - GENERAL

1.1 RELATED DOCUMENTS

- A. Drawings and general provisions of the Contract, including General and Supplementary Conditions and Division 01 Specification Sections, apply to this Section.

1.2 SUMMARY

- A. This Section includes the following:
 - 1. Hangers and supports for electrical equipment and systems.
 - 2. Construction requirements for concrete bases.
- B. Related Sections include the following:
 - 1. Division 26 Section "Noise And Vibration Controls For Electrical Systems" for products and installation requirements necessary for compliance with seismic criteria.

1.3 DEFINITIONS

- A. EMT: Electrical metallic tubing.
- B. IMC: Intermediate metal conduit.
- C. RMC: Rigid metal conduit.

1.4 PERFORMANCE REQUIREMENTS

- A. Delegated Design: Design supports for multiple raceways, including comprehensive engineering analysis by a qualified professional engineer, using performance requirements and design criteria indicated.
- B. Design supports for multiple raceways capable of supporting combined weight of supported systems and its contents.
- C. Design equipment supports capable of supporting combined operating weight of supported equipment and connected systems and components.
- D. Rated Strength: Adequate in tension, shear, and pullout force to resist maximum loads calculated or imposed for this Project, with a minimum structural safety factor of five times the applied force.

1.5 SUBMITTALS

- A. Product Data: For the following:
 - 1. Steel slotted support systems.
 - 2. Nonmetallic slotted support systems.

- B. Shop Drawings: Signed and sealed by a qualified professional engineer. Show fabrication and installation details and include calculations for the following:
 - 1. Trapeze hangers. Include Product Data for components.
 - 2. Steel slotted channel systems. Include Product Data for components.
 - 3. Nonmetallic slotted channel systems. Include Product Data for components.
 - 4. Equipment supports.
- C. Welding certificates.

1.6 QUALITY ASSURANCE

- A. Welding: Qualify procedures and personnel according to AWS D1.1/D1.1M, "Structural Welding Code - Steel."
- B. Comply with NFPA 70.

1.7 COORDINATION

- A. Coordinate size and location of concrete bases. Cast anchor-bolt inserts into bases. Concrete, reinforcement, and formwork requirements are specified in Division 03.

PART 2 - PRODUCTS

2.1 SUPPORT, ANCHORAGE, AND ATTACHMENT COMPONENTS

- A. Steel Slotted Support Systems: Comply with MFMA-4, factory-fabricated components for field assembly.
 - 1. Available Manufacturers: Subject to compliance with requirements, manufacturers offering products that may be incorporated into the Work include, but are not limited to, the following:
 - a. Allied Tube & Conduit.
 - b. Cooper B-Line, Inc.; a division of Cooper Industries.
 - c. ERICO International Corporation.
 - d. GS Metals Corp.
 - e. Thomas & Betts Corporation.
 - f. Unistrut; Tyco International, Ltd.
 - g. Wesanco, Inc.
 - 2. Metallic Coatings: Hot-dip galvanized after fabrication and applied according to MFMA-4.
 - 3. Nonmetallic Coatings: Manufacturer's standard PVC, polyurethane, or polyester coating applied according to MFMA-4.
 - 4. Painted Coatings: Manufacturer's standard painted coating applied according to MFMA-4.
 - 5. Channel Dimensions: Selected for applicable load criteria.
- B. Nonmetallic Slotted Support Systems: Structural-grade, factory-formed, glass-fiber-resin channels and angles with 9/16-inch- (14-mm-) diameter holes at a maximum of 8 inches (200 mm) o.c., in at least 1 surface.
 - 1. Available Manufacturers: Subject to compliance with requirements, manufacturers offering products that may be incorporated into the Work include, but are not limited to, the following:
 - a. Allied Tube & Conduit.
 - b. Cooper B-Line, Inc.; a division of Cooper Industries.

- c. Fabco Plastics Wholesale Limited.
 - d. Seasafe, Inc.
2. Fittings and Accessories: Products of channel and angle manufacturer and designed for use with those items.
 3. Fitting and Accessory Materials: Same as channels and angles, except metal items may be stainless steel.
 4. Rated Strength: Selected to suit applicable load criteria.
- C. Raceway and Cable Supports: As described in NECA 1 and NECA 101.
- D. Conduit and Cable Support Devices: Steel hangers, clamps, and associated fittings, designed for types and sizes of raceway or cable to be supported.
- E. Support for Conductors in Vertical Conduit: Factory-fabricated assembly consisting of threaded body and insulating wedging plug or plugs for non-armored electrical conductors or cables in riser conduits. Plugs shall have number, size, and shape of conductor gripping pieces as required to suit individual conductors or cables supported. Body shall be malleable iron.
- F. Structural Steel for Fabricated Supports and Restraints: ASTM A 36/A 36M, steel plates, shapes, and bars; black and galvanized.
- G. Mounting, Anchoring, and Attachment Components: Items for fastening electrical items or their supports to building surfaces include the following:
1. Powder-Actuated Fasteners: Threaded-steel stud, for use in hardened portland cement concrete, steel, or wood, with tension, shear, and pullout capacities appropriate for supported loads and building materials where used.
 - a. Available Manufacturers: Subject to compliance with requirements, manufacturers offering products that may be incorporated into the Work include, but are not limited to, the following:
 - 1) Hilti Inc.
 - 2) ITW Ramset/Red Head; a division of Illinois Tool Works, Inc.
 - 3) MKT Fastening, LLC.
 - 4) Simpson Strong-Tie Co., Inc.; Masterset Fastening Systems Unit.
 2. Mechanical-Expansion Anchors: Insert-wedge-type, stainless steel, for use in hardened portland cement concrete with tension, shear, and pullout capacities appropriate for supported loads and building materials in which used.
 - a. Available Manufacturers: Subject to compliance with requirements, manufacturers offering products that may be incorporated into the Work include, but are not limited to, the following:
 - 1) Cooper B-Line, Inc.; a division of Cooper Industries.
 - 2) Empire Tool and Manufacturing Co., Inc.
 - 3) Hilti Inc.
 - 4) ITW Ramset/Red Head; a division of Illinois Tool Works, Inc.
 - 5) MKT Fastening, LLC.
 3. Concrete Inserts: Steel or malleable-iron, slotted support system units similar to MSS Type 18; complying with MFMA-4 or MSS SP-58.
 4. Clamps for Attachment to Steel Structural Elements: MSS SP-58, type suitable for attached structural element.
 5. Through Bolts: Structural type, hex head, and high strength. Comply with ASTM A 325.
 6. Toggle Bolts: All-steel springhead type.
 7. Hanger Rods: Threaded steel.

2.2 FABRICATED METAL EQUIPMENT SUPPORT ASSEMBLIES

- A. Description: Welded or bolted, structural-steel shapes, shop or field fabricated to fit dimensions of supported equipment.
- B. Materials: Comply with requirements in Division 05 Section "Metal Fabrications" for steel shapes and plates.

PART 3 - EXECUTION

3.1 APPLICATION

- A. Comply with NECA 1 and NECA 101 for application of hangers and supports for electrical equipment and systems except if requirements in this Section are stricter.
- B. Maximum Support Spacing and Minimum Hanger Rod Size for Raceway: Space supports for EMT, IMC, and RMC as required by NFPA 70. Minimum rod size shall be 1/4 inch (6 mm) in diameter.
- C. Multiple Raceways or Cables: Install trapeze-type supports fabricated with steel slotted or other support system, sized so capacity can be increased by at least 25 percent in future without exceeding specified design load limits.
 - 1. Secure raceways and cables to these supports with two-bolt conduit clamps.
- D. Spring-steel clamps designed for supporting single conduits without bolts may be used for 1-1/2-inch (38-mm) and smaller raceways serving branch circuits and communication systems above suspended ceilings and for fastening raceways to trapeze supports.

3.2 SUPPORT INSTALLATION

- A. Comply with NECA 1 and NECA 101 for installation requirements except as specified in this Article.
- B. Raceway Support Methods: In addition to methods described in NECA 1, EMT, IMC, and RMC may be supported by openings through structure members, as permitted in NFPA 70.
- C. Strength of Support Assemblies: Where not indicated, select sizes of components so strength will be adequate to carry present and future static loads within specified loading limits. Minimum static design load used for strength determination shall be weight of supported components plus 200 lb (90 kg).
- D. Mounting and Anchorage of Surface-Mounted Equipment and Components: Anchor and fasten electrical items and their supports to building structural elements by the following methods unless otherwise indicated by code:
 - 1. To Wood: Fasten with lag screws or through bolts.
 - 2. To New Concrete: Bolt to concrete inserts.
 - 3. To Masonry: Approved toggle-type bolts on hollow masonry units and expansion anchor fasteners on solid masonry units.
 - 4. To Existing Concrete: Expansion anchor fasteners.
 - 5. Instead of expansion anchors, powder-actuated driven threaded studs provided with lock washers and nuts may be used in existing standard-weight concrete 4 inches (100 mm) thick or greater. Do not use for anchorage to lightweight-aggregate concrete or for slabs less than 4 inches (100 mm) thick.
 - 6. To Steel: Welded threaded studs complying with AWS D1.1/D1.1M, with lock washers and nuts.
 - 7. To Light Steel: Sheet metal screws.

8. Items Mounted on Hollow Walls and Nonstructural Building Surfaces: Mount cabinets, panelboards, disconnect switches, control enclosures, pull and junction boxes, transformers, and other devices on slotted-channel racks attached to substrate by means that meet seismic-restraint strength and anchorage requirements.

- E. Drill holes for expansion anchors in concrete at locations and to depths that avoid reinforcing bars.

3.3 INSTALLATION OF FABRICATED METAL SUPPORTS

- A. Comply with installation requirements in Division 05 Section "Metal Fabrications" for site-fabricated metal supports.
- B. Cut, fit, and place miscellaneous metal supports accurately in location, alignment, and elevation to support and anchor electrical materials and equipment.
- C. Field Welding: Comply with AWS D1.1/D1.1M.

3.4 CONCRETE BASES

- A. Construct concrete bases of dimensions indicated but not less than 4 inches (100 mm) larger in both directions than supported unit, and so anchors will be a minimum of 10 bolt diameters from edge of the base.
- B. Use 3000-psi (20.7-MPa), 28-day compressive-strength concrete. Concrete materials, reinforcement, and placement requirements are specified in Division 03 Section "Cast-in-Place Concrete."
- C. Anchor equipment to concrete base.
 1. Place and secure anchorage devices. Use supported equipment manufacturer's setting drawings, templates, diagrams, instructions, and directions furnished with items to be embedded.
 2. Install anchor bolts to elevations required for proper attachment to supported equipment.
 3. Install anchor bolts according to anchor-bolt manufacturer's written instructions.

3.5 PAINTING

- A. Touchup: Clean field welds and abraded areas of shop paint. Paint exposed areas immediately after erecting hangers and supports. Use same materials as used for shop painting. Comply with SSPC-PA 1 requirements for touching up field-painted surfaces.
 1. Apply paint by brush or spray to provide minimum dry film thickness of 2.0 mils (0.05 mm).
- B. Touchup: Comply with requirements in Division 09 painting Sections for cleaning and touchup painting of field welds, bolted connections, and abraded areas of shop paint on miscellaneous metal.
- C. Galvanized Surfaces: Clean welds, bolted connections, and abraded areas and apply galvanizing-repair paint to comply with ASTM A 780.

END OF SECTION 260529

SECTION 260533 - RACEWAY AND BOXES FOR ELECTRICAL SYSTEMS

PART 1 - GENERAL

1.1 RELATED DOCUMENTS

- A. Drawings and general provisions of the Contract, including General and Supplementary Conditions and Division 01 Specification Sections, apply to this Section.

1.2 SUMMARY

- A. This Section includes raceways, fittings, boxes, enclosures, and cabinets for electrical wiring.
- B. Related Sections include the following:
 - 1. Division 26 Section "Underground Ducts and Raceways for Electrical Systems" for exterior manholes, and underground utility construction.

1.3 DEFINITIONS

- A. EMT: Electrical metallic tubing.
- B. ENT: Electrical nonmetallic tubing.
- C. EPDM: Ethylene-propylene-diene terpolymer rubber.
- D. FMC: Flexible metal conduit.
- E. IMC: Intermediate metal conduit.
- F. LFMC: Liquidtight flexible metal conduit.
- G. LFNC: Liquidtight flexible nonmetallic conduit.
- H. NBR: Acrylonitrile-butadiene rubber.
- I. RNC: Rigid nonmetallic conduit.

1.4 SUBMITTALS

- A. Product Data: For surface raceways, wireways and fittings, floor boxes, hinged-cover enclosures, and cabinets.
- B. Shop Drawings: For the following raceway components. Include plans, elevations, sections, details, and attachments to other work.
 - 1. Custom enclosures and cabinets.
 - 2. For handholes and boxes for underground wiring, including the following:
 - a. Frame and cover design.

- b. Grounding details.
 - c. Dimensioned locations of cable rack inserts, and pulling-in and lifting irons.
 - d. Joint details.
 - C. Coordination Drawings: Conduit routing plans, drawn to scale, on which the following items are shown and coordinated with each other, based on input from installers of the items involved:
 - 1. Structural members in the paths of conduit groups with common supports.
 - 2. HVAC and plumbing items and architectural features in the paths of conduit groups with common supports.
 - D. Manufacturer Seismic Qualification Certification: Submit certification that enclosures and cabinets and their mounting provisions, including those for internal components, will withstand seismic forces defined in Division 26 Section "Vibration and Seismic Controls for Electrical Systems." Include the following:
 - 1. Basis for Certification: Indicate whether withstand certification is based on actual test of assembled components or on calculation.
 - a. The term "withstand" means "the cabinet or enclosure will remain in place without separation of any parts when subjected to the seismic forces specified and the unit will retain its enclosure characteristics, including its interior accessibility, after the seismic event."
 - 2. Dimensioned Outline Drawings of Equipment Unit: Identify center of gravity and locate and describe mounting and anchorage provisions.
 - 3. Detailed description of equipment anchorage devices on which the certification is based and their installation requirements.
 - E. Qualification Data: For professional engineer and testing agency.
 - F. Source quality-control test reports.
- 1.5 QUALITY ASSURANCE
- A. Electrical Components, Devices, and Accessories: Listed and labeled as defined in NFPA 70, Article 100, by a testing agency acceptable to authorities having jurisdiction, and marked for intended use.
 - B. Comply with NFPA 70.

PART 2 - PRODUCTS

2.1 METAL CONDUIT AND TUBING

- A. Available Manufacturers: Subject to compliance with requirements, manufacturers offering products that may be incorporated into the Work include, but are not limited to, the following:
- B. Manufacturers: Subject to compliance with requirements, provide products by one of the following:
 - 1. AFC Cable Systems, Inc.
 - 2. Alflex Inc.
 - 3. Allied Tube & Conduit; a Tyco International Ltd. Co.
 - 4. Anamet Electrical, Inc.; Anaconda Metal Hose.
 - 5. Electri-Flex Co.
 - 6. Manhattan/CDT/Cole-Flex.
 - 7. Maverick Tube Corporation.

8. O-Z Gedney; a unit of General Signal.
 9. Wheatland Tube Company.
- C. Rigid Steel Conduit: ANSI C80.1.
- D. IMC: ANSI C80.6.
- E. EMT: ANSI C80.3.
- F. FMC: Zinc-coated steel.
- G. LFMC: Flexible steel conduit with PVC jacket.
- H. Fittings for Conduit (Including all Types and Flexible and Liquidtight), EMT, and Cable: NEMA FB 1; listed for type and size raceway with which used, and for application and environment in which installed.
1. Fittings for EMT: Steel or die-cast, compression type.
 2. Coating for Fittings for PVC-Coated Conduit: Minimum thickness, 0.040 inch (1 mm), with overlapping sleeves protecting threaded joints.
- I. Joint Compound for Rigid Steel Conduit or IMC: Listed for use in cable connector assemblies, and compounded for use to lubricate and protect threaded raceway joints from corrosion and enhance their conductivity.

2.2 NONMETALLIC CONDUIT AND TUBING

- A. Available Manufacturers: Subject to compliance with requirements, manufacturers offering products that may be incorporated into the Work include, but are not limited to, the following:
- B. Manufacturers: Subject to compliance with requirements, provide products by one of the following:
1. AFC Cable Systems, Inc.
 2. Anamet Electrical, Inc.; Anaconda Metal Hose.
 3. Arco Corporation.
 4. CANTEX Inc.
 5. CertainTeed Corp.; Pipe & Plastics Group.
 6. Condux International, Inc.
 7. ElecSYS, Inc.
 8. Electri-Flex Co.
 9. Lamson & Sessions; Carlon Electrical Products.
 10. Manhattan/CDT/Cole-Flex.
 11. RACO; a Hubbell Company.
 12. Thomas & Betts Corporation.
- C. ENT: NEMA TC 13.
- D. RNC: NEMA TC 2, Type EPC-40-PVC, unless otherwise indicated.
- E. LFNC: UL 1660.
- F. Fittings for ENT and RNC: NEMA TC 3; match to conduit or tubing type and material.
- G. Fittings for LFNC: UL 514B.

2.3 OPTICAL FIBER/COMMUNICATIONS CABLE RACEWAY AND FITTINGS

- A. Available Manufacturers: Subject to compliance with requirements, manufacturers offering products that may be incorporated into the Work include, but are not limited to, the following:
- B. Manufacturers: Subject to compliance with requirements, provide products by one of the following:
 - 1. Arnco Corporation.
 - 2. Endot Industries Inc.
 - 3. IPEX Inc.
 - 4. Lamson & Sessions; Carlon Electrical Products.
- C. Description: Comply with UL 2024; flexible type, approved for plenum installation.

2.4 NONMETALLIC WIREWAYS

- A. Available Manufacturers: Subject to compliance with requirements, manufacturers offering products that may be incorporated into the Work include, but are not limited to, the following:
 - 1. Hoffman.
 - 2. Lamson & Sessions; Carlon Electrical Products.
- B. Description: Fiberglass polyester, extruded and fabricated to size and shape indicated, with no holes or knockouts. Cover is gasketed with oil-resistant gasket material and fastened with captive screws treated for corrosion resistance. Connections are flanged, with stainless-steel screws and oil-resistant gaskets.
- C. Description: PVC plastic, extruded and fabricated to size and shape indicated, with snap-on cover and mechanically coupled connections with plastic fasteners.
- D. Fittings and Accessories: Include couplings, offsets, elbows, expansion joints, adapters, hold-down straps, end caps, and other fittings to match and mate with wireways as required for complete system.

2.5 SURFACE RACEWAYS

- A. Surface Metal Raceways: Galvanized steel with snap-on covers. Manufacturer's standard enamel finish in color selected by Architect.
 - 1. Available Manufacturers: Subject to compliance with requirements, manufacturers offering products that may be incorporated into the Work include, but are not limited to, the following:
 - a. Thomas & Betts Corporation.
 - b. Walker Systems, Inc.; Wiremold Company (The).
 - c. Wiremold Company (The); Electrical Sales Division.
- B. Surface Nonmetallic Raceways: Two-piece construction, manufactured of rigid PVC with texture and color selected by Architect from manufacturer's standard colors.
 - 1. Available Manufacturers: Subject to compliance with requirements, manufacturers offering products that may be incorporated into the Work include, but are not limited to, the following:
 - a. Butler Manufacturing Company; Walker Division.
 - b. Enduro Systems, Inc.; Composite Products Division.
 - c. Hubbell Incorporated; Wiring Device-Kellems Division.
 - d. Lamson & Sessions; Carlon Electrical Products.
 - e. Panduit Corp.
 - f. Walker Systems, Inc.; Wiremold Company (The).

- g. Wiremold Company (The); Electrical Sales Division.

2.6 BOXES, ENCLOSURES, AND CABINETS

- A. Available Manufacturers: Subject to compliance with requirements, manufacturers offering products that may be incorporated into the Work include, but are not limited to, the following:
1. Cooper Crouse-Hinds; Div. of Cooper Industries, Inc.
 2. EGS/Appleton Electric.
 3. Erickson Electrical Equipment Company.
 4. Hoffman.
 5. Hubbell Incorporated; Killark Electric Manufacturing Co. Division.
 6. O-Z/Gedney; a unit of General Signal.
 7. RACO; a Hubbell Company.
 8. Robroy Industries, Inc.; Enclosure Division.
 9. Scott Fetzer Co.; Adalet Division.
 10. Spring City Electrical Manufacturing Company.
 11. Thomas & Betts Corporation.
 12. Walker Systems, Inc.; Wiremold Company (The).
 13. Woodhead, Daniel Company; Woodhead Industries, Inc. Subsidiary.
- B. Sheet Metal Outlet and Device Boxes: NEMA OS 1.
- C. Cast-Metal Outlet and Device Boxes: NEMA FB 1, ferrous alloy, Type FD, with gasketed cover.
- D. Nonmetallic Outlet and Device Boxes: NEMA OS 2.
- E. Metal Floor Boxes: Cast or sheet metal, fully adjustable, rectangular.
- F. Small Sheet Metal Pull and Junction Boxes: NEMA OS 1.
- G. Cast-Metal Access, Pull, and Junction Boxes: NEMA FB 1, cast aluminum with gasketed cover.
- H. Hinged-Cover Enclosures: NEMA 250, Type 1, with continuous-hinge cover with flush latch, unless otherwise indicated.
1. Metal Enclosures: Steel, finished inside and out with manufacturer's standard enamel.
 2. Nonmetallic Enclosures: Plastic, finished inside with radio-frequency-resistant paint.
- I. Cabinets:
1. NEMA 250, Type 1, galvanized-steel box with removable interior panel and removable front, finished inside and out with manufacturer's standard enamel.
 2. Hinged door in front cover with flush latch and concealed hinge.
 3. Key latch to match panelboards.
 4. Metal barriers to separate wiring of different systems and voltage.
 5. Accessory feet where required for freestanding equipment.

2.7 HANDHOLES AND BOXES FOR EXTERIOR UNDERGROUND WIRING

- A. Description: Comply with SCTE 77.
1. Color of Frame and Cover: Gray.
 2. Configuration: Units shall be designed for flush burial and have closed bottom, unless otherwise indicated.

3. Cover: Weatherproof, secured by tamper-resistant locking devices and having structural load rating consistent with enclosure.
4. Cover Finish: Nonskid finish shall have a minimum coefficient of friction of 0.50.
5. Cover Legend: Molded lettering, as indicated for each service.
6. Conduit Entrance Provisions: Conduit-terminating fittings shall mate with entering ducts for secure, fixed installation in enclosure wall.
7. Handholes 12 inches wide by 24 inches long (300 mm wide by 600 mm long) and larger shall have inserts for cable racks and pulling-in irons installed before concrete is poured.

B. Fiberglass Handholes and Boxes with Polymer-Concrete Frame and Cover: Sheet-molded, fiberglass-reinforced, polyester-resin enclosure joined to polymer-concrete top ring or frame.

1. Available Manufacturers: Subject to compliance with requirements, manufacturers offering products that may be incorporated into the Work include, but are not limited to, the following:
2. Manufacturers: Subject to compliance with requirements, provide products by one of the following:
3. Basis-of-Design Product: Subject to compliance with requirements, provide the product indicated on Drawings or a comparable product by one of the following:
 - a. Armorcast Products Company.
 - b. Carson Industries LLC.
 - c. Christy Concrete Products.
 - d. Synertech Moulded Products, Inc.; a division of Oldcastle Precast.

C. Fiberglass Handholes and Boxes: Molded of fiberglass-reinforced polyester resin, with covers of fiberglass.

1. Available Manufacturers: Subject to compliance with requirements, manufacturers offering products that may be incorporated into the Work include, but are not limited to, the following:
2. Manufacturers: Subject to compliance with requirements, provide products by one of the following:
3. Basis-of-Design Product: Subject to compliance with requirements, provide the product indicated on Drawings or a comparable product by one of the following:
 - a. Carson Industries LLC.
 - b. Christy Concrete Products.
 - c. Nordic Fiberglass, Inc.

2.8 SLEEVES FOR RACEWAYS

- A. Steel Pipe Sleeves: ASTM A 53/A 53M, Type E, Grade B, Schedule 40, galvanized steel, plain ends.
- B. Cast-Iron Pipe Sleeves: Cast or fabricated "wall pipe," equivalent to ductile-iron pressure pipe, with plain ends and integral waterstop, unless otherwise indicated.
- C. Sleeves for Rectangular Openings: Galvanized sheet steel with minimum 0.052- or 0.138-inch (1.3- or 3.5-mm) thickness as indicated and of length to suit application.
- D. Coordinate sleeve selection and application with selection and application of firestopping specified in Division 07 Section "Penetration Firestopping."

2.9 SLEEVE SEALS

- A. Available Manufacturers: Subject to compliance with requirements, manufacturers offering products that may be incorporated into the Work include, but are not limited to, the following:
- B. Manufacturers: Subject to compliance with requirements, provide products by one of the following:

1. Advance Products & Systems, Inc.
2. Calpico, Inc.
3. Metraflex Co.
4. Pipeline Seal and Insulator, Inc.

C. Description: Modular sealing device, designed for field assembly, to fill annular space between sleeve and cable.

1. Sealing Elements: EPDM interlocking links shaped to fit surface of cable or conduit. Include type and number required for material and size of raceway or cable.
2. Pressure Plates: Carbon steel. Include two for each sealing element.
3. Connecting Bolts and Nuts: Carbon steel with corrosion-resistant coating of length required to secure pressure plates to sealing elements. Include one for each sealing element.

2.10 SOURCE QUALITY CONTROL FOR UNDERGROUND ENCLOSURES

A. Handhole and Pull-Box Prototype Test: Test prototypes of handholes and boxes for compliance with SCTE 77. Strength tests shall be for specified tier ratings of products supplied.

1. Tests of materials shall be performed by a independent testing agency.
2. Strength tests of complete boxes and covers shall be by either an independent testing agency or manufacturer. A qualified registered professional engineer shall certify tests by manufacturer.
3. Testing machine pressure gages shall have current calibration certification complying with ISO 9000 and ISO 10012, and traceable to NIST standards.

PART 3 - EXECUTION

3.1 RACEWAY APPLICATION

A. Outdoors: Apply raceway products as specified below, unless otherwise indicated:

1. Exposed Conduit: Rigid steel conduit.
2. Concealed Conduit, Aboveground: Rigid steel conduit.
3. Underground Conduit: RNC, Type EPC-40-PVC, direct buried.
4. Connection to Vibrating Equipment (Including Transformers and Hydraulic, Pneumatic, Electric Solenoid, or Motor-Driven Equipment): LFMC.
5. Boxes and Enclosures, Aboveground: NEMA 250, Type 3R.
6. Application of Handholes and Boxes for Underground Wiring:
 - a. Handholes and Pull Boxes in Driveway, Parking Lot, and Off-Roadway Locations, Subject to Occasional, Nondeliberate Loading by Heavy Vehicles: Fiberglass-reinforced polyester resin, SCTE 77, Tier 15 structural load rating.
 - b. Handholes and Pull Boxes in Sidewalk and Similar Applications with a Safety Factor for Nondeliberate Loading by Vehicles: Heavy-duty fiberglass units with polymer-concrete frame and cover, SCTE 77, Tier 8 structural load rating.
 - c. Handholes and Pull Boxes Subject to Light-Duty Pedestrian Traffic Only: Fiberglass-reinforced polyester resin, structurally tested according to SCTE 77 with 3000-lbf (13 345-N) vertical loading.

B. Comply with the following indoor applications, unless otherwise indicated:

1. Exposed, Not Subject to Physical Damage: EMT.
2. Exposed, Not Subject to Severe Physical Damage: IMC.
3. Exposed and Subject to Severe Physical Damage: Rigid steel conduit. Includes raceways in the following locations:

- a. Where surface mounted conduit is required on the exterior of the building.
 - 4. Concealed in Ceilings and Interior Walls and Partitions: EMT.
 - 5. Connection to Vibrating Equipment (Including Transformers and Hydraulic, Pneumatic, Electric Solenoid, or Motor-Driven Equipment): FMC, except use LFMC in damp or wet locations.
 - 6. Damp or Wet Locations: Rigid steel conduit.
 - 7. Raceways for Optical Fiber or Communications Cable in Spaces Used for Environmental Air: EMT.
 - 8. Raceways for Optical Fiber or Communications Cable Risers in Vertical Shafts: EMT.
 - 9. Raceways for Concealed General Purpose Distribution of Optical Fiber or Communications Cable: EMT.
 - 10. Boxes and Enclosures: NEMA 250, Type 1, except use NEMA 250, Type 4, stainless steel in damp or wet locations.
 - C. Minimum Raceway Size: 3/4-inch (21-mm) trade size.
 - D. Raceway Fittings: Compatible with raceways and suitable for use and location.
 - 1. Rigid and Intermediate Steel Conduit: Use threaded rigid steel conduit fittings, unless otherwise indicated.
 - 2. PVC Externally Coated, Rigid Steel Conduits: Use only fittings listed for use with that material. Patch and seal all joints, nicks, and scrapes in PVC coating after installing conduits and fittings. Use sealant recommended by fitting manufacturer.
 - E. Install nonferrous conduit or tubing for circuits operating above 60 Hz. Where aluminum raceways are installed for such circuits and pass through concrete, install in nonmetallic sleeve.
 - F. Do not install aluminum conduits in contact with concrete.
- 3.2 INSTALLATION
- A. Comply with NECA 1 for installation requirements applicable to products specified in Part 2 except where requirements on Drawings or in this Article are stricter.
 - B. Keep raceways at least 6 inches (150 mm) away from parallel runs of flues and steam or hot-water pipes. Install horizontal raceway runs above water and steam piping.
 - C. Complete raceway installation before starting conductor installation.
 - D. Support raceways as specified in Division 26 Section "Hangers and Supports for Electrical Systems."
 - E. Arrange stub-ups so curved portions of bends are not visible above the finished slab.
 - F. Install no more than the equivalent of three 90-degree bends in any conduit run except for communications conduits, for which fewer bends are allowed.
 - G. Conceal conduit and EMT within finished walls, ceilings, and floors, unless otherwise indicated.
 - H. Threaded Conduit Joints, Exposed to Wet, Damp, Corrosive, or Outdoor Conditions: Apply listed compound to threads of raceway and fittings before making up joints. Follow compound manufacturer's written instructions.
 - I. Raceway Terminations at Locations Subject to Moisture or Vibration: Use insulating bushings to protect conductors, including conductors smaller than No. 4 AWG.
 - J. Install pull wires in empty raceways. Use polypropylene or monofilament plastic line with not less than 200-lb (90-kg) tensile strength. Leave at least 12 inches (300 mm) of slack at each end of pull wire.

- K. Raceways for Optical Fiber and Communications Cable: Install raceways, metallic and nonmetallic, rigid and flexible, as follows:
 - 1. 3/4-Inch (19-mm) Trade Size and Smaller: Install raceways in maximum lengths of 50 feet (15 m).
 - 2. 1-Inch (25-mm) Trade Size and Larger: Install raceways in maximum lengths of 75 feet (23 m).
 - 3. Install with a maximum of two 90-degree bends or equivalent for each length of raceway unless Drawings show stricter requirements. Separate lengths with pull or junction boxes or terminations at distribution frames or cabinets where necessary to comply with these requirements.

- L. Install raceway sealing fittings at suitable, approved, and accessible locations and fill them with listed sealing compound. For concealed raceways, install each fitting in a flush steel box with a blank cover plate having a finish similar to that of adjacent plates or surfaces. Install raceway sealing fittings at the following points:
 - 1. Where conduits pass from warm to cold locations, such as boundaries of refrigerated spaces.
 - 2. Where otherwise required by NFPA 70.

- M. Flexible Conduit Connections: Use maximum of 72 inches (1830 mm) of flexible conduit for recessed and semirecessed lighting fixtures, equipment subject to vibration, noise transmission, or movement; and for transformers and motors.
 - 1. Use LFMC in damp or wet locations subject to severe physical damage.
 - 2. Use LFMC or LFNC in damp or wet locations not subject to severe physical damage.

- N. Recessed Boxes in Masonry Walls: Saw-cut opening for box in center of cell of masonry block, and install box flush with surface of wall.

- O. Set metal floor boxes level and flush with finished floor surface.

3.3 INSTALLATION OF UNDERGROUND CONDUIT

- A. Direct-Buried Conduit:
 - 1. Install manufactured rigid steel conduit elbows for stub-ups at poles and equipment and at building entrances through the floor.
 - a. Couple steel conduits to ducts with adapters designed for this purpose, and encase coupling with 3 inches (75 mm) of concrete.
 - b. For stub-ups at equipment mounted on outdoor concrete bases, extend steel conduit horizontally a minimum of 60 inches (1500 mm) from edge of equipment pad or foundation. Install insulated grounding bushings on terminations at equipment.
 - 2. Warning Planks: Bury warning planks approximately 12 inches (300 mm) above direct-buried conduits, placing them 24 inches (600 mm) o.c. Align planks along the width and along the centerline of conduit.

3.4 INSTALLATION OF UNDERGROUND HANDHOLES AND BOXES

- A. Install handholes and boxes level and plumb and with orientation and depth coordinated with connecting conduits to minimize bends and deflections required for proper entrances.

- B. Unless otherwise indicated, support units on a level bed of crushed stone or gravel, graded from 1/2-inch (12.5-mm) sieve to No. 4 (4.75-mm) sieve and compacted to same density as adjacent undisturbed earth.

- C. Elevation: In paved areas, set so cover surface will be flush with finished grade. Set covers of other enclosures 1 inch (25 mm) above finished grade.
- D. Install handholes and boxes with bottom below the frost line, below grade.
- E. Install removable hardware, including pulling eyes, cable stanchions, cable arms, and insulators, as required for installation and support of cables and conductors and as indicated. Select arm lengths to be long enough to provide spare space for future cables, but short enough to preserve adequate working clearances in the enclosure.
- F. Field-cut openings for conduits according to enclosure manufacturer's written instructions. Cut wall of enclosure with a tool designed for material to be cut. Size holes for terminating fittings to be used, and seal around penetrations after fittings are installed.

3.5 SLEEVE INSTALLATION FOR ELECTRICAL PENETRATIONS

- A. Coordinate sleeve selection and application with selection and application of firestopping specified in Division 07 Section "Penetration Firestopping."
- B. Concrete Slabs and Walls: Install sleeves for penetrations unless core-drilled holes or formed openings are used. Install sleeves during erection of slabs and walls.
- C. Use pipe sleeves unless penetration arrangement requires rectangular sleeved opening.
- D. Rectangular Sleeve Minimum Metal Thickness:
 - 1. For sleeve cross-section rectangle perimeter less than 50 inches (1270 mm) and no side greater than 16 inches (400 mm), thickness shall be 0.052 inch (1.3 mm).
 - 2. For sleeve cross-section rectangle perimeter equal to, or greater than, 50 inches (1270 mm) and 1 or more sides equal to, or greater than, 16 inches (400 mm), thickness shall be 0.138 inch (3.5 mm).
- E. Fire-Rated Assemblies: Install sleeves for penetrations of fire-rated floor and wall assemblies unless openings compatible with firestop system used are fabricated during construction of floor or wall.
- F. Cut sleeves to length for mounting flush with both surfaces of walls.
- G. Extend sleeves installed in floors 2 inches (50 mm) above finished floor level.
- H. Size pipe sleeves to provide 1/4-inch (6.4-mm) annular clear space between sleeve and raceway unless sleeve seal is to be installed or unless seismic criteria require different clearance.
- I. Seal space outside of sleeves with grout for penetrations of concrete and masonry and with approved joint compound for gypsum board assemblies.
- J. Interior Penetrations of Non-Fire-Rated Walls and Floors: Seal annular space between sleeve and raceway, using joint sealant appropriate for size, depth, and location of joint. Refer to Division 07 Section "Joint Sealants" for materials and installation.
- K. Fire-Rated-Assembly Penetrations: Maintain indicated fire rating of walls, partitions, ceilings, and floors at raceway penetrations. Install sleeves and seal with firestop materials. Comply with Division 07 Section "Penetration Firestopping."
- L. Roof-Penetration Sleeves: Seal penetration of individual raceways with flexible, boot-type flashing units applied in coordination with roofing work.

- M. Aboveground, Exterior-Wall Penetrations: Seal penetrations using sleeves and mechanical sleeve seals. Select sleeve size to allow for 1-inch (25-mm) annular clear space between pipe and sleeve for installing mechanical sleeve seals.
- N. Underground, Exterior-Wall Penetrations: Install cast-iron "wall pipes" for sleeves. Size sleeves to allow for 1-inch (25-mm) annular clear space between raceway and sleeve for installing mechanical sleeve seals.

3.6 SLEEVE-SEAL INSTALLATION

- A. Install to seal underground, exterior wall penetrations.
- B. Use type and number of sealing elements recommended by manufacturer for raceway material and size. Position raceway in center of sleeve. Assemble mechanical sleeve seals and install in annular space between raceway and sleeve. Tighten bolts against pressure plates that cause sealing elements to expand and make watertight seal.

3.7 FIRESTOPPING

- A. Apply firestopping to electrical penetrations of fire-rated floor and wall assemblies to restore original fire-resistance rating of assembly. Firestopping materials and installation requirements are specified in Division 07 Section "Penetration Firestopping."

3.8 PROTECTION

- A. Provide final protection and maintain conditions that ensure coatings, finishes, and cabinets are without damage or deterioration at time of Substantial Completion.
 - 1. Repair damage to galvanized finishes with zinc-rich paint recommended by manufacturer.
 - 2. Repair damage to PVC or paint finishes with matching touchup coating recommended by manufacturer.

END OF SECTION 260533

SECTION 260543-UNDERGROUND DUCTS AND RACEWAYS FOR ELECTRICAL SYSTEMS

PART 1 - GENERAL

1.1 RELATED DOCUMENTS

- A. Drawings and general provisions of the Contract, including General and Supplementary Conditions and Division 01 Specification Sections, apply to this Section.

1.2 SUMMARY

- A. This Section includes the following:
 - 1. Conduit for direct-buried runs.
 - 2. Handholes and boxes.

1.3 DEFINITION

- A. RNC: Rigid nonmetallic conduit.

1.4 SUBMITTALS

- A. Product Data: For the following:
 - 1. Conduits and their accessories, including elbows, end bells, bends, fittings, and solvent cement.
 - 2. Accessories for handholes, boxes, and other utility structures.
 - 3. Warning tape.
 - 4. Warning planks.
- B. Shop Drawings for Factory-Fabricated Handholes and Boxes Other Than Precast Concrete: Include dimensioned plans, sections, and elevations, and fabrication and installation details, including the following:
 - 1. Cover design.
 - 2. Grounding details.
- C. Product Certificates: For concrete and steel used in precast concrete handholes as required by ASTM C 858.
- D. Source quality-control test reports.
- E. Field quality-control test reports.

1.5 QUALITY ASSURANCE

- A. Comply with ANSI C2.
- B. Comply with NFPA 70.

1.6 DELIVERY, STORAGE, AND HANDLING

- A. Deliver ducts to Project site with ends capped. Store nonmetallic ducts with supports to prevent bending, warping, and deforming.

1.7 COORDINATION

- A. Coordinate layout and installation of ducts, handholes, and boxes with final arrangement of other utilities, site grading, and surface features as determined in the field.
- B. Coordinate elevations of ducts and duct-bank entrances into handholes and boxes with final locations and profiles of ducts and duct banks as determined by coordination with other utilities, underground obstructions, and surface features. Revise locations and elevations from those indicated as required to suit field conditions and to ensure that duct runs drain to handholes and as approved by Architect.

PART 2 - PRODUCTS

2.1 CONDUIT

- A. Rigid Steel Conduit: Galvanized. Comply with ANSI C80.1.
- B. RNC: NEMA TC 2, Type EPC-40-PVC, UL 651, with matching fittings by same manufacturer as the conduit, complying with NEMA TC 3 and UL 514B.

2.2 HANDHOLES AND BOXES OTHER THAN PRECAST CONCRETE

- A. Description: Comply with SCTE 77.
 - 1. Color: Gray.
 - 2. Configuration: Units shall be designed for flush burial and have closed bottom, unless otherwise indicated.
 - 3. Cover: Weatherproof, secured by tamper-resistant locking devices and having structural load rating consistent with enclosure.
 - 4. Cover Finish: Nonskid finish shall have a minimum coefficient of friction of 0.50.
 - 5. Cover Legend: Molded lettering, as indicated for each service.
 - 6. Duct Entrance Provisions: Duct-terminating fittings shall mate with entering ducts for secure, fixed installation in enclosure wall.
 - 7. Handholes 12 inches wide by 24 inches long (300 mm wide by 600 mm long) and larger shall have factory-installed inserts for cable racks and pulling-in irons.
- B. Polymer Concrete Handholes and Boxes with Polymer Concrete Cover: Molded of sand and aggregate, bound together with a polymer resin, and reinforced with steel or fiberglass or a combination of the two.
 - 1. Manufacturers: Subject to compliance with requirements, provide products by one of the following:
 - a. Armorcast Products Company.
 - b. Carson Industries LLC.
 - c. CDR Systems Corporation.
 - d. NewBasis.
- C. Fiberglass Handholes and Boxes: Molded of fiberglass-reinforced polyester resin, with covers of fiberglass.
 - 1. Manufacturers: Subject to compliance with requirements, provide products by one of the following:
 - a. Carson Industries LLC.

- b. Christy Concrete Products.
 - c. Nordic Fiberglass, Inc.
- D. High-Density Plastic Boxes: Injection molded of high-density polyethylene or copolymer-polypropylene. Cover shall be polymer concrete.
- 1. Manufacturers: Subject to compliance with requirements, provide products by one of the following:
 - a. Carson Industries LLC.
 - b. Nordic Fiberglass, Inc.
 - c. PenCell Plastics.

2.3 SOURCE QUALITY CONTROL

- A. Test and inspect precast concrete utility structures according to ASTM C 1037.
- B. Nonconcrete Handhole and Pull-Box Prototype Test: Test prototypes of manholes and boxes for compliance with SCTE 77. Strength tests shall be for specified tier ratings of products supplied.
 - 1. Tests of materials shall be performed by a independent testing agency.
 - 2. Strength tests of complete boxes and covers shall be by either an independent testing agency or the manufacturer. A qualified registered professional engineer shall certify tests by manufacturer.
 - 3. Testing machine pressure gages shall have current calibration certification complying with ISO 9000 and ISO 10012, and traceable to NIST standards.

PART 3 - EXECUTION

3.1 UNDERGROUND ENCLOSURE APPLICATION

- A. Handholes and Boxes for 600 V and Less, Including Telephone, Communications, and Data Wiring:
 - 1. Units in Roadways and Other Deliberate Traffic Paths: Precast concrete. AASHTO HB 17, H-10 structural load rating.
 - 2. Units in Driveway, Parking Lot, and Off-Roadway Locations, Subject to Occasional, Nondeliberate Loading by Heavy Vehicles: Precast concrete, AASHTO HB 17, H-20] [Polymer concrete, SCTE 77, Tier 15 structural load rating.
 - 3. Units in Sidewalk and Similar Applications with a Safety Factor for Nondeliberate Loading by Vehicles: Precast concrete, AASHTO HB 17, H-10 structural load rating.
 - 4. Units Subject to Light-Duty Pedestrian Traffic Only: Fiberglass-reinforced polyester resin, structurally tested according to SCTE 77 with 3000-lbf (13 345-N) vertical loading.

3.2 EARTHWORK

- A. Excavation and Backfill: Comply with Division 31 Section "Earthwork," but do not use heavy-duty, hydraulic-operated, compaction equipment.
- B. Restore surface features at areas disturbed by excavation and reestablish original grades, unless otherwise indicated. Replace removed sod immediately after backfilling is completed.
- C. Cut and patch existing pavement in the path of underground ducts and utility structures according to Division 01 Section "Cutting and Patching."

3.3 INSTALLATION OF HANDHOLES AND BOXES OTHER THAN PRECAST CONCRETE

- A. Install handholes and boxes level and plumb and with orientation and depth coordinated with connecting ducts to minimize bends and deflections required for proper entrances. Use box extension if required to match depths of ducts, and seal joint between box and extension as recommended by the manufacturer.
- B. Unless otherwise indicated, support units on a level bed of crushed stone or gravel, graded from 1/2-inch (12.7-mm) sieve to No. 4 (4.75-mm) sieve and compacted to same density as adjacent undisturbed earth.
- C. Elevation: In paved areas and trafficways, set so cover surface will be flush with finished grade. Set covers of other handholes 1 inch (25 mm) above finished grade.
- D. Install handholes and boxes with bottom below the frost line.
- E. Install removable hardware, including pulling eyes, cable stanchions, cable arms, and insulators, as required for installation and support of cables and conductors and as indicated. Select arm lengths to be long enough to provide spare space for future cables, but short enough to preserve adequate working clearances in the enclosure.
- F. Field-cut openings for ducts and conduits according to enclosure manufacturer's written instructions. Cut wall of enclosure with a tool designed for material to be cut. Size holes for terminating fittings to be used, and seal around penetrations after fittings are installed.
- G. For enclosures installed in asphalt paving and subject to occasional, nondeliberate, heavy-vehicle loading, form and pour a concrete ring encircling, and in contact with, enclosure and with top surface screeded to top of box cover frame. Bottom of ring shall rest on compacted earth.
 - 1. Concrete: 3000 psi (20 kPa), 28-day strength, complying with Division 03 Section "Cast-in-Place Concrete," with a troweled finish.
 - 2. Dimensions: 10 inches wide by 12 inches deep (250 mm wide by 300 mm deep).

3.4 GROUNDING

- A. Ground underground ducts and utility structures according to Division 26 Section "Grounding and Bonding for Electrical Systems."

3.5 FIELD QUALITY CONTROL

- A. Perform the following tests and inspections and prepare test reports:
 - 1. Demonstrate capability and compliance with requirements on completion of installation of underground ducts and utility structures.
 - 2. Pull aluminum or wood test mandrel through duct to prove joint integrity and test for out-of-round duct. Provide mandrel equal to 80 percent fill of duct. If obstructions are indicated, remove obstructions and retest.
 - 3. Test handhole grounding to ensure electrical continuity of grounding and bonding connections. Measure and report ground resistance as specified in Division 26 Section "Grounding and Bonding for Electrical Systems."
- B. Correct deficiencies and retest as specified above to demonstrate compliance.

3.6 CLEANING

- A. Pull leather-washer-type duct cleaner, with graduated washer sizes, through full length of ducts. Follow with rubber duct swab for final cleaning and to assist in spreading lubricant throughout ducts.

- B. Clean internal surfaces of manholes, including sump. Remove foreign material.

END OF SECTION 260543

SECTION 260553 - IDENTIFICATION FOR ELECTRICAL SYSTEMS

PART 1 - GENERAL

1.1 RELATED DOCUMENTS

- A. Drawings and general provisions of the Contract, including General and Supplementary Conditions and Division 01 Specification Sections, apply to this Section.

1.2 SUMMARY

- A. Section Includes:
 - 1. Identification for raceways.
 - 2. Identification of power and control cables.
 - 3. Identification for conductors.
 - 4. Underground-line warning tape.
 - 5. Warning labels and signs.
 - 6. Instruction signs.
 - 7. Equipment identification labels.
 - 8. Miscellaneous identification products.

1.3 SUBMITTALS

- A. Product Data: For each electrical identification product indicated.
- B. Samples: For each type of label and sign to illustrate size, colors, lettering style, mounting provisions, and graphic features of identification products.
- C. Identification Schedule: An index of nomenclature of electrical equipment and system components used in identification signs and labels.

1.4 QUALITY ASSURANCE

- A. Comply with ANSI A13.1 and IEEE C2.
- B. Comply with NFPA 70.
- C. Comply with 29 CFR 1910.144 and 29 CFR 1910.145.
- D. Comply with ANSI Z535.4 for safety signs and labels.
- E. Adhesive-attached labeling materials, including label stocks, laminating adhesives, and inks used by label printers, shall comply with UL 969.

1.5 COORDINATION

- A. Coordinate identification names, abbreviations, colors, and other features with requirements in other Sections requiring identification applications, Drawings, Shop Drawings, manufacturer's wiring diagrams, and the Operation and Maintenance Manual; and with those required by codes, standards, and 29 CFR 1910.145. Use consistent designations throughout Project.

- B. Coordinate installation of identifying devices with completion of covering and painting of surfaces where devices are to be applied.
- C. Coordinate installation of identifying devices with location of access panels and doors.
- D. Install identifying devices before installing acoustical ceilings and similar concealment.

PART 2 - PRODUCTS

2.1 POWER RACEWAY IDENTIFICATION MATERIALS

- A. Comply with ANSI A13.1 for minimum size of letters for legend and for minimum length of color field for each raceway size.
- B. Colors for Raceways Carrying Circuits at 600 V or Less:
 - 1. Black letters on an orange field.
 - 2. Legend: Indicate voltage and system or service type.
- C. Self-Adhesive Vinyl Labels for Raceways Carrying Circuits at 600 V or Less: Preprinted, flexible label laminated with a clear, weather- and chemical-resistant coating and matching wraparound adhesive tape for securing ends of legend label.
- D. Snap-Around Labels for Raceways Carrying Circuits at 600 V or Less: Slit, pretensioned, flexible, preprinted, color-coded acrylic sleeve, with diameter sized to suit diameter of raceway or cable it identifies and to stay in place by gripping action.
- E. Snap-Around, Color-Coding Bands for Raceways Carrying Circuits at 600 V or Less: Slit, pretensioned, flexible, solid-colored acrylic sleeve, 2 inches (50 mm) long, with diameter sized to suit diameter of raceway or cable it identifies and to stay in place by gripping action.
- F. Tape and Stencil for Raceways Carrying Circuits More Than 600 V: 4-inch- (100-mm-) wide black stripes on 10-inch (250-mm) centers diagonally over orange background that extends full length of raceway or duct and is 12 inches (300 mm) wide. Stop stripes at legends.
- G. Metal Tags: Brass or aluminum, 2 by 2 by 0.05 inch (50 by 50 by 1.3 mm), with stamped legend, punched for use with self-locking cable tie fastener.
- H. Write-On Tags: Polyester tag, 0.015 inch (0.38 mm) thick, with corrosion-resistant grommet and cable tie for attachment to conductor or cable.
 - 1. Marker for Tags: Machine-printed, permanent, waterproof, black ink marker recommended by printer manufacturer.

2.2 POWER AND CONTROL CABLE IDENTIFICATION MATERIALS

- A. Comply with ANSI A13.1 for minimum size of letters for legend and for minimum length of color field for each raceway and cable size.
- B. Self-Adhesive Vinyl Labels: Preprinted, flexible label laminated with a clear, weather- and chemical-resistant coating and matching wraparound adhesive tape for securing ends of legend label.
- C. Metal Tags: Brass or aluminum, 2 by 2 by 0.05 inch (50 by 50 by 1.3 mm), with stamped legend, punched for use with self-locking cable tie fastener.

- D. Write-On Tags: Polyester tag, 0.015 inch (0.38 mm) thick, with corrosion-resistant grommet and cable tie for attachment to conductor or cable.
 - 1. Marker for Tags: Machine-printed, permanent, waterproof, black ink marker recommended by printer manufacturer.
- E. Snap-Around Labels: Slit, pretensioned, flexible, preprinted, color-coded acrylic sleeve, with diameter sized to suit diameter of raceway or cable it identifies and to stay in place by gripping action.
- F. Snap-Around, Color-Coding Bands: Slit, pretensioned, flexible, solid-colored acrylic sleeve, 2 inches (50 mm) long, with diameter sized to suit diameter of raceway or cable it identifies and to stay in place by gripping action.

2.3 CONDUCTOR IDENTIFICATION MATERIALS

- A. Color-Coding Conductor Tape: Colored, self-adhesive vinyl tape not less than 3 mils (0.08 mm) thick by 1 to 2 inches (25 to 50 mm) wide.
- B. Self-Adhesive Vinyl Labels: Preprinted, flexible label laminated with a clear, weather- and chemical-resistant coating and matching wraparound adhesive tape for securing ends of legend label.
- C. Snap-Around Labels: Slit, pretensioned, flexible, preprinted, color-coded acrylic sleeve, with diameter sized to suit diameter of raceway or cable it identifies and to stay in place by gripping action.
- D. Snap-Around, Color-Coding Bands: Slit, pretensioned, flexible, solid-colored acrylic sleeve, 2 inches (50 mm) long, with diameter sized to suit diameter of raceway or cable it identifies and to stay in place by gripping action.
- E. Marker Tapes: Vinyl or vinyl-cloth, self-adhesive wraparound type, with circuit identification legend machine printed by thermal transfer or equivalent process.
- F. Write-On Tags: Polyester tag, 0.015 inch (0.38 mm) thick, with corrosion-resistant grommet and cable tie for attachment to conductor or cable.
 - 1. Marker for Tags: Machine-printed, permanent, waterproof, black ink marker recommended by printer manufacturer.

2.4 FLOOR MARKING TAPE

- A. 2-inch- (50-mm-) wide, 5-mil (0.125-mm) pressure-sensitive vinyl tape, with black and white stripes and clear vinyl overlay.

2.5 UNDERGROUND-LINE WARNING TAPE

- A. Tape:
 - 1. Recommended by manufacturer for the method of installation and suitable to identify and locate underground electrical and communications utility lines.
 - 2. Printing on tape shall be permanent and shall not be damaged by burial operations.
 - 3. Tape material and ink shall be chemically inert, and not subject to degrading when exposed to acids, alkalis, and other destructive substances commonly found in soils.
- B. Color and Printing:
 - 1. Comply with ANSI Z535.1 through ANSI Z535.5.
 - 2. Inscriptions for Red-Colored Tapes: ELECTRIC LINE, HIGH VOLTAGE.
 - 3. Inscriptions for Orange-Colored Tapes: TELEPHONE CABLE, CATV CABLE, COMMUNICATIONS CABLE, OPTICAL FIBER CABLE.

C. Tag: Type I:

1. Pigmented polyolefin, bright-colored, continuous-printed on one side with the inscription of the utility, compounded for direct-burial service.
2. Thickness: 4 mils (0.1 mm).
3. Weight: 18.5 lb/1000 sq. ft. (9.0 kg/100 sq. m).
4. 3-Inch (75-mm) Tensile According to ASTM D 882: 30 lbf (133.4 N), and 2500 psi (17.2 MPa).

D. Tag: Type II:

1. Multilayer laminate consisting of high-density polyethylene scrim coated with pigmented polyolefin, bright-colored, continuous-printed on one side with the inscription of the utility, compounded for direct-burial service.
2. Thickness: 12 mils (0.3 mm).
3. Weight: 36.1 lb/1000 sq. ft. (17.6 kg/100 sq. m).
4. 3-Inch (75-mm) Tensile According to ASTM D 882: 400 lbf (1780 N), and 11,500 psi (79.2 MPa).

E. Tag: Type ID:

1. Detectable three-layer laminate, consisting of a printed pigmented polyolefin film, a solid aluminum-foil core, and a clear protective film that allows inspection of the continuity of the conductive core, bright-colored, continuous-printed on one side with the inscription of the utility, compounded for direct-burial service.
2. Overall Thickness: 5 mils (0.125 mm).
3. Foil Core Thickness: 0.35 mil (0.00889 mm).
4. Weight: 28 lb/1000 sq. ft. (13.7 kg/100 sq. m).
5. 3-Inch (75-mm) Tensile According to ASTM D 882: 70 lbf (311.3 N), and 4600 psi (31.7 MPa).

F. Tag: Type IID:

1. Reinforced, detectable three-layer laminate, consisting of a printed pigmented woven scrim, a solid aluminum-foil core, and a clear protective film that allows inspection of the continuity of the conductive core, bright-colored, continuous-printed on one side with the inscription of the utility, compounded for direct-burial service.
2. Overall Thickness: 8 mils (0.2 mm).
3. Foil Core Thickness: 0.35 mil (0.00889 mm).
4. Weight: 34 lb/1000 sq. ft. (16.6 kg/100 sq. m).
5. 3-Inch (75-mm) Tensile According to ASTM D 882: 300 lbf (1334 N), and 12,500 psi (86.1 MPa).

2.6 WARNING LABELS AND SIGNS

A. Comply with NFPA 70 and 29 CFR 1910.145.

B. Self-Adhesive Warning Labels: Factory-printed, multicolor, pressure-sensitive adhesive labels, configured for display on front cover, door, or other access to equipment unless otherwise indicated.

C. Baked-Enamel Warning Signs:

1. Preprinted aluminum signs, punched or drilled for fasteners, with colors, legend, and size required for application.
2. 1/4-inch (6.4-mm) grommets in corners for mounting.
3. Nominal size, 7 by 10 inches (180 by 250 mm).

D. Metal-Backed, Butyrate Warning Signs:

1. Weather-resistant, nonfading, preprinted, cellulose-acetate butyrate signs with 0.0396-inch (1-mm) galvanized-steel backing; and with colors, legend, and size required for application.
2. 1/4-inch (6.4-mm) grommets in corners for mounting.

3. Nominal size, 10 by 14 inches (250 by 360 mm).

E. Warning label and sign shall include, but are not limited to, the following legends:

1. Multiple Power Source Warning: "DANGER - ELECTRICAL SHOCK HAZARD - EQUIPMENT HAS MULTIPLE POWER SOURCES."
2. Workspace Clearance Warning: "WARNING - OSHA REGULATION - AREA IN FRONT OF ELECTRICAL EQUIPMENT MUST BE KEPT CLEAR FOR 36 INCHES (915 MM)."

2.7 INSTRUCTION SIGNS

A. Engraved, laminated acrylic or melamine plastic, minimum 1/16 inch (1.6 mm) thick for signs up to 20 sq. inches (129 sq. cm) and 1/8 inch (3.2 mm) thick for larger sizes.

1. Engraved legend with black letters on white face.
2. Punched or drilled for mechanical fasteners.
3. Framed with mitered acrylic molding and arranged for attachment at applicable equipment.

B. Adhesive Film Label: Machine printed, in black, by thermal transfer or equivalent process. Minimum letter height shall be 3/8 inch (10 mm).

C. Adhesive Film Label with Clear Protective Overlay: Machine printed, in black, by thermal transfer or equivalent process. Minimum letter height shall be 3/8 inch (10 mm). Overlay shall provide a weatherproof and UV-resistant seal for label.

2.8 EQUIPMENT IDENTIFICATION LABELS

A. Adhesive Film Label: Machine printed, in black, by thermal transfer or equivalent process. Minimum letter height shall be 3/8 inch (10 mm).

B. Adhesive Film Label with Clear Protective Overlay: Machine printed, in black, by thermal transfer or equivalent process. Minimum letter height shall be 3/8 inch (10 mm). Overlay shall provide a weatherproof and UV-resistant seal for label.

C. Self-Adhesive, Engraved, Laminated Acrylic or Melamine Label: Adhesive backed, with white letters on a dark-gray background. Minimum letter height shall be 3/8 inch (10 mm).

D. Engraved, Laminated Acrylic or Melamine Label: Punched or drilled for screw mounting. White letters on a dark-gray background. Minimum letter height shall be 3/8 inch (10 mm).

E. Stenciled Legend: In nonfading, waterproof, black ink or paint. Minimum letter height shall be 1 inch (25 mm).

2.9 CABLE TIES

A. General-Purpose Cable Ties: Fungus inert, self extinguishing, one piece, self locking, Type 6/6 nylon.

1. Minimum Width: 3/16 inch (5 mm).
2. Tensile Strength at 73 deg F (23 deg C), According to ASTM D 638: 12,000 psi (82.7 MPa).
3. Temperature Range: Minus 40 to plus 185 deg F (Minus 40 to plus 85 deg C).
4. Color: Black except where used for color-coding.

B. UV-Stabilized Cable Ties: Fungus inert, designed for continuous exposure to exterior sunlight, self extinguishing, one piece, self locking, Type 6/6 nylon.

1. Minimum Width: 3/16 inch (5 mm).
2. Tensile Strength at 73 deg F (23 deg C), According to ASTM D 638: 12,000 psi (82.7 MPa).
3. Temperature Range: Minus 40 to plus 185 deg F (Minus 40 to plus 85 deg C).
4. Color: Black.

C. Plenum-Rated Cable Ties: Self extinguishing, UV stabilized, one piece, self locking.

1. Minimum Width: 3/16 inch (5 mm).
2. Tensile Strength at 73 deg F (23 deg C), According to ASTM D 638: 7000 psi (48.2 MPa).
3. UL 94 Flame Rating: 94V-0.
4. Temperature Range: Minus 50 to plus 284 deg F (Minus 46 to plus 140 deg C).
5. Color: Black.

2.10 MISCELLANEOUS IDENTIFICATION PRODUCTS

- A. Paint: Comply with requirements in Division 09 painting Sections for paint materials and application requirements. Select paint system applicable for surface material and location (exterior or interior).
- B. Fasteners for Labels and Signs: Self-tapping, stainless-steel screws or stainless-steel machine screws with nuts and flat and lock washers.

PART 3 - EXECUTION

3.1 INSTALLATION

- A. Verify identity of each item before installing identification products.
- B. Location: Install identification materials and devices at locations for most convenient viewing without interference with operation and maintenance of equipment.
- C. Apply identification devices to surfaces that require finish after completing finish work.
- D. Self-Adhesive Identification Products: Clean surfaces before application, using materials and methods recommended by manufacturer of identification device.
- E. Attach signs and plastic labels that are not self-adhesive type with mechanical fasteners appropriate to the location and substrate.
- F. System Identification Color-Coding Bands for Raceways and Cables: Each color-coding band shall completely encircle cable or conduit. Place adjacent bands of two-color markings in contact, side by side. Locate bands at changes in direction, at penetrations of walls and floors, at 50-foot (15-m) maximum intervals in straight runs, and at 25-foot (7.6-m) maximum intervals in congested areas.
- G. Aluminum Wraparound Marker Labels and Metal Tags: Secure tight to surface of conductor or cable at a location with high visibility and accessibility.
- H. Cable Ties: For attaching tags. Use general-purpose type, except as listed below:
1. Outdoors: UV-stabilized nylon.
 2. In Spaces Handling Environmental Air: Plenum rated.
- I. Underground-Line Warning Tape: During backfilling of trenches install continuous underground-line warning tape directly above line at 6 to 8 inches (150 to 200 mm) below finished grade. Use multiple tapes where width of multiple lines installed in a common trench or concrete envelope exceeds 16 inches (400 mm) overall.

- J. Painted Identification: Comply with requirements in Division 09 painting Sections for surface preparation and paint application.

3.2 IDENTIFICATION SCHEDULE

- A. Power-Circuit Conductor Identification, 600 V or Less: For conductors in vaults, pull and junction boxes, manholes, and handholes, use color-coding conductor tape to identify the phase.
 - 1. Color-Coding for Phase and Voltage Level Identification, 600 V or Less: Use colors listed below for ungrounded service, feeder, and branch-circuit conductors.
 - a. Color shall be factory applied or field applied for sizes larger than No. 8 AWG, if authorities having jurisdiction permit.
 - b. Colors for 208/120-V Circuits:
 - 1) Phase A: Black.
 - 2) Phase B: Red.
 - 3) Phase C: Blue.
 - c. Field-Applied, Color-Coding Conductor Tape: Apply in half-lapped turns for a minimum distance of 6 inches (150 mm) from terminal points and in boxes where splices or taps are made. Apply last two turns of tape with no tension to prevent possible unwinding. Locate bands to avoid obscuring factory cable markings.
- B. Power-Circuit Conductor Identification, More than 600 V: For conductors in vaults, pull and junction boxes, manholes, and handholes, use nonmetallic plastic tag holder with adhesive-backed phase tags, and a separate tag with the circuit designation.
- C. Install instructional sign including the color-code for grounded and ungrounded conductors using adhesive-film-type labels.
- D. Conductors to Be Extended in the Future: Attach marker tape to conductors and list source.
- E. Auxiliary Electrical Systems Conductor Identification: Identify field-installed alarm, control, and signal connections.
 - 1. Identify conductors, cables, and terminals in enclosures and at junctions, terminals, and pull points. Identify by system and circuit designation.
 - 2. Use system of marker tape designations that is uniform and consistent with system used by manufacturer for factory-installed connections.
 - 3. Coordinate identification with Project Drawings, manufacturer's wiring diagrams, and the Operation and Maintenance Manual.
- F. Locations of Underground Lines: Identify with underground-line warning tape for power, lighting, communication, and control wiring and optical fiber cable.
 - 1. Limit use of underground-line warning tape to direct-buried cables.
 - 2. Install underground-line warning tape for both direct-buried cables and cables in raceway.
- G. Workspace Indication: Install floor marking tape to show working clearances in the direction of access to live parts. Workspace shall be as required by NFPA 70 and 29 CFR 1926.403 unless otherwise indicated. Do not install at flush-mounted panelboards and similar equipment in finished spaces.
- H. Warning Labels for Indoor Cabinets, Boxes, and Enclosures for Power and Lighting: Self-adhesive warning labels.
 - 1. Comply with 29 CFR 1910.145.
 - 2. Identify system voltage with black letters on an orange background.

3. Apply to exterior of door, cover, or other access.
4. For equipment with multiple power or control sources, apply to door or cover of equipment including, but not limited to, the following:
 - a. Power transfer switches.
 - b. Controls with external control power connections.
- I. Operating Instruction Signs: Install instruction signs to facilitate proper operation and maintenance of electrical systems and items to which they connect. Install instruction signs with approved legend where instructions are needed for system or equipment operation.
- J. Emergency Operating Instruction Signs: Install instruction signs with white legend on a red background with minimum 3/8-inch- (10-mm-) high letters for emergency instructions at equipment used for power transfer.
- K. Equipment Identification Labels: On each unit of equipment, install unique designation label that is consistent with wiring diagrams, schedules, and the Operation and Maintenance Manual. Apply labels to disconnect switches and protection equipment, central or master units, control panels, control stations, terminal cabinets, and racks of each system. Systems include power, lighting, control, communication, signal, monitoring, and alarm systems unless equipment is provided with its own identification.
 1. Labeling Instructions:
 - a. Indoor Equipment: Engraved, laminated acrylic or melamine label. Unless otherwise indicated, provide a single line of text with 1/2-inch- (13-mm-) high letters on 1-1/2-inch- (38-mm-) high label; where two lines of text are required, use labels 2 inches (50 mm) high.
 - b. Outdoor Equipment: Engraved, laminated acrylic or melamine label.
 - c. Elevated Components: Increase sizes of labels and letters to those appropriate for viewing from the floor.
 - d. Unless provided with self-adhesive means of attachment, fasten labels with appropriate mechanical fasteners that do not change the NEMA or NRTL rating of the enclosure.
 2. Equipment to Be Labeled:
 - a. Panelboards: Typewritten directory of circuits in the location provided by panelboard manufacturer. Panelboard identification shall be self-adhesive, engraved, laminated acrylic or melamine label.
 - b. Enclosures and electrical cabinets.
 - c. Access doors and panels for concealed electrical items.
 - d. Switchboards.
 - e. Transformers: Label that includes tag designation shown on Drawings for the transformer, feeder, and panelboards or equipment supplied by the secondary.
 - f. Emergency system boxes and enclosures.
 - g. Enclosed switches.
 - h. Enclosed circuit breakers.
 - i. Enclosed controllers.
 - j. Power transfer equipment.
 - k. Contactors.
 - l. Remote-controlled switches, dimmer modules, and control devices.
 - m. Power-generating units.

END OF SECTION 260553

SECTION 260574 – OVERCURRENT PROTECTIVE DEVICE ARC-FLASH STUDY

PART 1 - GENERAL

1.1 RELATED DOCUMENTS

- A. Drawings and general provisions of the Contract, including General and Supplementary Conditions and Division 01 Specification Sections, apply to this Section.

1.2 SUMMARY

- A. Section includes a computer-based, arc-flash study to determine the arc-flash hazard distance and the incident energy to which personnel could be exposed during work on or near electrical equipment. The study scope shall include only new equipment, although existing equipment affecting the study shall be identified, surveyed, documented, and included in the study. The following shall be considered: Existing feeder specifics & lengths, short circuit values at existing service, utility's overcurrent types & settings, existing overcurrent device types & settings, existing motor loads, etc. as determined by the study preparer.

1.3 DEFINITIONS

- A. Existing to Remain: Existing items of construction that are not to be removed and that are not otherwise indicated to be removed, removed and salvaged, or removed and reinstalled.
- B. One-Line Diagram: A diagram which shows, by means of single lines and graphic symbols, the course of an electric circuit or system of circuits and the component devices or parts used therein.
- C. Protective Device: A device that senses when an abnormal current flow exists and then removes the affected portion from the system.
- D. SCCR: Short-circuit current rating.
- E. Service: The conductors and equipment for delivering electric energy from the serving utility to the wiring system of the premises served.

1.4 ACTION SUBMITTALS

- A. Product Data: For computer software program to be used for studies.
- B. Other Action Submittals: Submit the following submittals after the approval of system protective devices submittals. Submittals shall be in both printed & digital form.
 - 1. Arc-flash study input data, including completed computer program input data sheets.
 - 2. Arc-flash study report; signed, dated, and sealed by a qualified professional engineer.
 - a. Submit study report for action prior to receiving final approval of the distribution equipment submittals. If formal completion of studies will cause delay in equipment manufacturing, obtain approval from Architect for preliminary submittal of sufficient study data to ensure that the selection of devices and associated characteristics is satisfactory.

1.5 INFORMATIONAL SUBMITTALS

- A. Qualification Data: For Arc-Flash Study Software Developer, Arc-Flash Study Specialist, & Field Adjusting Agency.
- B. Product Certificates: For arc-flash hazard analysis software, certifying compliance with IEEE 1584 and NFPA 70E.

1.6 CLOSEOUT SUBMITTALS

- A. Maintenance procedures according to requirements in NFPA 70E shall be provided in the equipment manuals.
- B. Operation and Maintenance Procedures: In addition to items specified in Section 01 78 23 "Operation and Maintenance Data," provide maintenance procedures for use by Owner's personnel that comply with requirements in NFPA 70E.

1.7 QUALITY ASSURANCE

- A. Studies shall use computer programs that are distributed nationally and are in wide use. Software algorithms shall comply with requirements of standards and guides specified in this Section. Manual calculations are unacceptable.
- B. Arc-Flash Study Software Developer Qualifications: An entity that owns and markets computer software used for studies, having performed successful studies of similar magnitude on electrical distribution systems using similar devices.
 - 1. The computer program shall be developed under the charge of a licensed professional engineer who holds IEEE Computer Society's Certified Software Development Professional certification.
- C. Arc-Flash Study Specialist Qualifications: Professional engineer in charge of performing the study, analyzing the arc flash, and documenting recommendations, licensed in the state where Project is located. All elements of the study shall be performed under the direct supervision and control of this professional engineer.
- D. Field Adjusting Agency Qualifications: An independent agency, with the experience and capability to adjust overcurrent devices and to conduct the testing indicated, that is a member company of the International Electrical Testing Association or is a nationally recognized testing laboratory (NRTL) as defined by OSHA in 29 CFR 1910.7, and that is acceptable to authorities having jurisdiction.

PART 2 - PRODUCTS

2.1 COMPUTER SOFTWARE DEVELOPERS

- A. Software Developers:
 - SKM Systems Analysis, Inc.
 - Operation Technology, Inc.
 - ESA, Inc
- B. Comply with IEEE 1584 and NFPA 70E.

- C. Analytical features of device coordination study computer software program shall have the capability to calculate "mandatory," "very desirable," and "desirable" features as listed in IEEE 399.

2.2 ARC-FLASH STUDY REPORT CONTENT

- A. Executive summary.
- B. Study descriptions, purpose, basis and scope.
- C. One-line diagram, showing the following:
 - 1. Protective device designations and ampere ratings.
 - 2. Cable size and lengths.
 - 3. Transformer kilovolt ampere (kVA) and voltage ratings.
 - 4. Motor and generator designations and kVA ratings.
 - 5. Switchgear, switchboard, motor-control center and panelboard designations.
- D. Study Input Data: As described in "Power System Data" Article.
- E. Arc-Flash Study Output:
 - 1. Interrupting Duty Report: Three-phase and unbalanced fault calculations, showing the following for each overcurrent device location:
 - a. Voltage.
 - b. Calculated symmetrical fault-current magnitude and angle.
 - c. Fault-point X/R ratio.
 - d. No AC Decrement (NACD) ratio.
 - e. Equivalent impedance.
 - f. Multiplying factors for 2-, 3-, 5-, and 8-cycle circuit breakers rated on a symmetrical basis.
 - g. Multiplying factors for 2-, 3-, 5-, and 8-cycle circuit breakers rated on a total basis.
- F. Incident Energy and Flash Protection Boundary Calculations:
 - 1. Arcing fault magnitude.
 - 2. Protective device clearing time.
 - 3. Duration of arc.
 - 4. Arc-flash boundary.
 - 5. Working distance.
 - 6. Incident energy.
 - 7. Hazard risk category.
 - 8. Recommendations for arc-flash energy reduction.
- G. Fault study input data, case descriptions, and fault-current calculations including a definition of terms and guide for interpretation of the computer printout.

2.3 ARC-FLASH WARNING LABELS

- A. Comply with requirements in Section 26 05 53 "Identification for Electrical Systems." Produce a 3.5-by-5-inch thermal transfer label of high-adhesion polyester for each work location included in the analysis.
- B. The label shall have an orange header with the wording, "WARNING, ARC-FLASH HAZARD," and shall include the following information taken directly from the arc-flash hazard analysis:
 - 1. Location designation.
 - 2. Nominal voltage.

3. Flash protection boundary.
4. Hazard risk category.
5. Incident energy.
6. Working distance.
7. Engineering report number, revision number, and issue date.

C. Labels shall be machine printed, with no field-applied markings.

PART 3 - EXECUTION

3.1 EXAMINATION

- A. Examine Project overcurrent protective device submittals. Proceed with arc-flash study only after relevant equipment submittals have been assembled. Overcurrent protective devices that have not been submitted and approved prior to arc-flash study may not be used in study.

3.2 ARC-FLASH HAZARD ANALYSIS

- A. Comply with NFPA 70E and its Annex D for hazard analysis study.
- B. Calculate maximum and minimum contributions of fault-current size.
1. The minimum calculation shall assume that the utility contribution is at a minimum and shall assume no motor load.
 2. The maximum calculation shall assume a maximum contribution from the utility and shall assume motors to be operating under full-load conditions.
- C. Calculate the arc-flash protection boundary and incident energy at locations in the electrical distribution system where personnel could perform work on energized parts.
- D. Include medium- and low-voltage equipment locations, except equipment rated 240-V ac or less fed from transformers less than 125 kVA.
- E. Safe working distances shall be specified for calculated fault locations based on the calculated arc-flash boundary, considering incident energy of 1.2 cal/sq.cm.
- F. Incident energy calculations shall consider the accumulation of energy over time when performing arc-flash calculations on buses with multiple sources. Iterative calculations shall take into account the changing current contributions, as the sources are interrupted or decremented with time. Fault contribution from motors and generators shall be decremented as follows:
1. Fault contribution from induction motors should not be considered beyond three to five cycles.
 2. Fault contribution from synchronous motors and generators should be decayed to match the actual decrement of each as closely as possible (e.g., contributions from permanent magnet generators will typically decay from 10 per unit to three per unit after 10 cycles).
- G. Arc-flash computation shall include both line and load side of a circuit breaker as follows:
1. When the circuit breaker is in a separate enclosure.
 2. When the line terminals of the circuit breaker are separate from the work location.
- H. Base arc-flash calculations on actual overcurrent protective device clearing time. Cap maximum clearing time at two seconds based on IEEE 1584, Section B.1.2.

3.3 POWER SYSTEM DATA

- A. Obtain all data necessary for the conduct of the arc-flash hazard analysis.
1. Verify completeness of data supplied on the one-line diagram on Drawings and under "Preparatory Studies" Paragraph in "Arc-Flash Hazard Analysis" Article. Call discrepancies to the attention of Architect.
 2. For new equipment, use characteristics submitted under the provisions of action submittals and information submittals for this Project.
 3. For existing equipment, whether or not relocated, obtain required electrical distribution system data by field investigation and surveys, conducted by qualified technicians and engineers.
- B. Electrical Survey Data: Gather and tabulate the following input data to support study. Comply with recommendations in IEEE 1584 and NFPA 70E as to the amount of detail that is required to be acquired in the field. Field data gathering shall be under the direct supervision and control of the engineer in charge of performing the study, and shall be by the engineer or its representative who holds NETA ETT Level III certification or NICET Electrical Power Testing Level III certification.
1. Product Data for overcurrent protective devices specified in other Sections and involved in overcurrent protective device coordination studies. Use equipment designation tags that are consistent with electrical distribution system diagrams, overcurrent protective device submittals, input and output data, and recommended device settings.
 2. Obtain electrical power utility impedance at the service.
 3. Power sources and ties.
 4. Short-circuit current at each system bus, three phase and line-to-ground.
 5. Full-load current of all loads.
 6. Voltage level at each bus.
 7. For transformers, include kVA, primary and secondary voltages, connection type, impedance, X/R ratio, taps measured in per cent, and phase shift.
 8. For reactors, provide manufacturer and model designation, voltage rating and impedance.
 9. For circuit breakers and fuses, provide manufacturer and model designation. List type of breaker, type of trip and available range of settings, SCCR, current rating, and breaker settings.
 10. Generator short-circuit current contribution data, including short-circuit reactance, rated kVA, rated voltage, and X/R ratio.
 11. For relays, provide manufacturer and model designation, current transformer ratios, potential transformer ratios, and relay settings.
 12. Busway manufacturer and model designation, current rating, impedance, lengths, and conductor material.
 13. Motor horsepower and NEMA MG 1 code letter designation.
 14. Low-voltage cable sizes, lengths, number, conductor material and conduit material (magnetic or nonmagnetic).
 15. Medium-voltage cable sizes, lengths, conductor material, and cable construction and metallic shield performance parameters.

3.4 LABELING

- A. Apply one arc-flash label for 600-V ac, 480-V ac, and applicable 208-V ac panelboards and disconnects and for each of the following locations:
1. Motor-control center.
 2. Low-voltage switchboard.
 3. Switchgear.
 4. Control panel.

3.5 APPLICATION OF WARNING LABELS

- A. Install the arc-fault warning labels under the direct supervision and control of the Arc-Flash Study Specialist.

3.6 DEMONSTRATION

- A. Engage the Arc-Flash Study Specialist to train Owner's maintenance personnel in the potential arc-flash hazards associated with working on energized equipment and the significance of the arc-flash warning labels.

END OF SECTION

SECTION 260923 - LIGHTING CONTROL DEVICES

PART 1 - GENERAL

1.1 RELATED DOCUMENTS

- A. Drawings and general provisions of the Contract, including General and Supplementary Conditions and Division 01 Specification Sections, apply to this Section.

1.2 SUMMARY

- A. This Section includes the following lighting control devices:
 - 1. Time switches.
 - 2. Outdoor photoelectric switches.
 - 3. Indoor occupancy sensors.
 - 4. Lighting contactors.
 - 5. Emergency shunt relays.
- B. Related Sections include the following:
 - 1. Division 26 Section "Wiring Devices" for wall-box dimmers, wall-switch occupancy sensors, and manual light switches.

1.3 DEFINITIONS

- A. LED: Light-emitting diode.
- B. PIR: Passive infrared.

1.4 SUBMITTALS

- A. Product Data: For each type of product indicated.
- B. Shop Drawings: Show installation details for occupancy and light-level sensors.
 - 1. Interconnection diagrams showing field-installed wiring.
- C. Field quality-control test reports.
- D. Operation and Maintenance Data: For each type of product to include in emergency, operation, and maintenance manuals.

1.5 QUALITY ASSURANCE

- A. Electrical Components, Devices, and Accessories: Listed and labeled as defined in NFPA 70, Article 100, by a testing agency acceptable to authorities having jurisdiction, and marked for intended use.

1.6 COORDINATION

- A. Coordinate layout and installation of ceiling-mounted devices with other construction that penetrates ceilings or is supported by them, including light fixtures, HVAC equipment, smoke detectors, fire-suppression system, and partition assemblies.

PART 2 - PRODUCTS

2.1 OUTDOOR PHOTOELECTRIC SWITCHES

- A. Manufacturers: Subject to compliance with requirements, provide products by one of the following:
 - 1. TORK.
 - 2. Watt Stopper (The).
- B. Description: Solid state, with SPST dry contacts rated for 1800-VA tungsten or 1000-VA inductive, to operate connected relay, contactor coils, or microprocessor input; complying with UL 773A.
 - 1. Light-Level Monitoring Range: 1.5 to 10 fc (16.14 to 108 lx), with an adjustment for turn-on and turn-off levels within that range, and a directional lens in front of photocell to prevent fixed light sources from causing turn-off.
 - 2. Time Delay: 15-second minimum, to prevent false operation.
 - 3. Surge Protection: Metal-oxide varistor, complying with IEEE C62.41.1, IEEE C62.41.2, and IEEE 62.45 for Category A1 locations.
 - 4. Mounting: Twist lock complying with IEEE C136.10, with base-and-stem mounting or stem-and-swivel mounting accessories as required to direct sensor to the north sky exposure.

2.2 INDOOR OCCUPANCY SENSORS

- A. Manufacturers: Subject to compliance with requirements, provide products by one of the following:
 - 1. Watt Stopper (The).
- B. General Description: Wall- or ceiling-mounting, solid-state units with a separate relay unit.
 - 1. Operation: Unless otherwise indicated, turn lights on when covered area is occupied and off when unoccupied; with a time delay for turning lights off, adjustable over a minimum range of 1 to 15 minutes.
 - 2. Sensor Output: Contacts rated to operate the connected relay, complying with UL 773A. Sensor shall be powered from the relay unit.
 - 3. Relay Unit: Dry contacts rated for 20-A ballast load at 120- and 277-V ac, for 13-A tungsten at 120-V ac, and for 1 hp at 120-V ac. Power supply to sensor shall be 24-V dc, 150-mA, Class 2 power source as defined by NFPA 70.
 - 4. Mounting:
 - a. Sensor: Suitable for mounting in any position on a standard outlet box.
 - b. Relay: Externally mounted through a 1/2-inch (13-mm) knockout in a standard electrical enclosure.
 - c. Time-Delay and Sensitivity Adjustments: Recessed and concealed behind hinged door.
 - 5. Indicator: LED, to show when motion is being detected during testing and normal operation of the sensor.
 - 6. Bypass Switch: Override the on function in case of sensor failure.
 - 7. Automatic Light-Level Sensor: Adjustable from 2 to 200 fc (21.5 to 2152 lx); keep lighting off when selected lighting level is present.

- C. PIR Type: Ceiling mounting; detect occupancy by sensing a combination of heat and movement in area of coverage.
 - 1. Detector Sensitivity: Detect occurrences of 6-inch- (150-mm-) minimum movement of any portion of a human body that presents a target of not less than 36 sq. in. (232 sq. cm).
 - 2. Detection Coverage (Room): Detect occupancy anywhere in a circular area of 1000 sq. ft. (93 sq. m) when mounted on a 96-inch- (2440-mm-) high ceiling.
 - 3. Detection Coverage (Corridor): Detect occupancy within 90 feet (27.4 m) when mounted on a 10-foot- (3-m-) high ceiling.

- D. Ultrasonic Type: Ceiling mounting; detect occupancy by sensing a change in pattern of reflected ultrasonic energy in area of coverage.
 - 1. Detector Sensitivity: Detect a person of average size and weight moving not less than 12 inches (305 mm) in either a horizontal or a vertical manner at an approximate speed of 12 inches/s (305 mm/s).
 - 2. Detection Coverage (Small Room): Detect occupancy anywhere within a circular area of 600 sq. ft. (56 sq. m) when mounted on a 96-inch- (2440-mm-) high ceiling.
 - 3. Detection Coverage (Standard Room): Detect occupancy anywhere within a circular area of 1000 sq. ft. (93 sq. m) when mounted on a 96-inch- (2440-mm-) high ceiling.
 - 4. Detection Coverage (Large Room): Detect occupancy anywhere within a circular area of 2000 sq. ft. (186 sq. m) when mounted on a 96-inch- (2440-mm-) high ceiling.
 - 5. Detection Coverage (Corridor): Detect occupancy anywhere within 90 feet (27.4 m) when mounted on a 10-foot- (3-m-) high ceiling in a corridor not wider than 14 feet (4.3 m).

- E. Dual-Technology Type: Ceiling mounting; detect occupancy by using a combination of PIR and ultrasonic detection methods in area of coverage. Particular technology or combination of technologies that controls on-off functions shall be selectable in the field by operating controls on unit.
 - 1. Sensitivity Adjustment: Separate for each sensing technology.
 - 2. Detector Sensitivity: Detect occurrences of 6-inch- (150-mm-) minimum movement of any portion of a human body that presents a target of not less than 36 sq. in. (232 sq. cm), and detect a person of average size and weight moving not less than 12 inches (305 mm) in either a horizontal or a vertical manner at an approximate speed of 12 inches/s (305 mm/s).
 - 3. Detection Coverage (Standard Room): Detect occupancy anywhere within a circular area of 1000 sq. ft. (93 sq. m) when mounted on a 96-inch- (2440-mm-) high ceiling.

2.3 LIGHTING CONTACTORS

- A. Manufacturers: Subject to compliance with requirements, provide products by one of the following:
 - 1. Allen-Bradley/Rockwell Automation.
 - 2. ASCO Power Technologies, LP; a division of Emerson Electric Co.
 - 3. Eaton Electrical Inc.; Cutler-Hammer Products.
 - 4. GE Industrial Systems; Total Lighting Control.
 - 5. Grasslin Controls Corporation; a GE Industrial Systems Company.
 - 6. Hubbell Lighting.
 - 7. Lithonia Lighting; Acuity Lighting Group, Inc.
 - 8. MicroLite Lighting Control Systems.
 - 9. Square D; Schneider Electric.
 - 10. TORK.
 - 11. Touch-Plate, Inc.
 - 12. Watt Stopper (The).

- B. Description: Electrically operated and electrically held, combination type with fusible switch, complying with NEMA ICS 2 and UL 508.

1. Current Rating for Switching: Listing or rating consistent with type of load served, including tungsten filament, inductive, and high-inrush ballast (ballast with 15 percent or less total harmonic distortion of normal load current).
2. Fault Current Withstand Rating: Equal to or exceeding the available fault current at the point of installation.
3. Enclosure: Comply with NEMA 250.
4. Provide with control and pilot devices as scheduled, matching the NEMA type specified for the enclosure.

C. BAS Interface: Provide hardware interface to enable the BAS to monitor and control lighting contactors.

1. Monitoring: On-off status.
2. Control: On-off operation.

2.4 EMERGENCY SHUNT RELAY

A. Manufacturers: Subject to compliance with requirements, provide products by one of the following:

1. Lighting Control and Design, Inc.

B. Description: Normally closed, electrically held relay, arranged for wiring in parallel with manual or automatic switching contacts; complying with UL 924.

1. Coil Rating: 120/277 V.

2.5 CONDUCTORS AND CABLES

A. Power Wiring to Supply Side of Remote-Control Power Sources: Not smaller than No. 12 AWG. Comply with requirements in Division 26 Section "Low-Voltage Electrical Power Conductors and Cables."

B. Classes 2 and 3 Control Cable: Multiconductor cable with stranded-copper conductors not smaller than No. 18 AWG. Comply with requirements in Division 26 Section "Low-Voltage Electrical Power Conductors and Cables."

C. Class 1 Control Cable: Multiconductor cable with stranded-copper conductors not smaller than No. 14 AWG. Comply with requirements in Division 26 Section "Low-Voltage Electrical Power Conductors and Cables."

PART 3 - EXECUTION

3.1 SENSOR INSTALLATION

A. Install and aim sensors in locations to achieve not less than 90 percent coverage of areas indicated. Do not exceed coverage limits specified in manufacturer's written instructions.

3.2 CONTACTOR INSTALLATION

A. Mount electrically held lighting contactors with elastomeric isolator pads, to eliminate structure-borne vibration, unless contactors are installed in an enclosure with factory-installed vibration isolators.

3.3 WIRING INSTALLATION

- A. Wiring Method: Comply with Division 26 Section "Low-Voltage Electrical Power Conductors and Cables." Minimum conduit size shall be 1/2 inch (13 mm).
- B. Wiring within Enclosures: Comply with NECA 1. Separate power-limited and nonpower-limited conductors according to conductor manufacturer's written instructions.
- C. Size conductors according to lighting control device manufacturer's written instructions, unless otherwise indicated.
- D. Splices, Taps, and Terminations: Make connections only on numbered terminal strips in junction, pull, and outlet boxes; terminal cabinets; and equipment enclosures.

3.4 IDENTIFICATION

- A. Identify components and power and control wiring according to Division 26 Section "Identification for Electrical Systems."
 - 1. Identify controlled circuits in lighting contactors.
 - 2. Identify circuits or luminaires controlled by photoelectric and occupancy sensors at each sensor.
- B. Label time switches and contactors with a unique designation.

3.5 FIELD QUALITY CONTROL

- A. Perform the following field tests and inspections and prepare test reports:
 - 1. After installing time switches and sensors, and after electrical circuitry has been energized, adjust and test for compliance with requirements.
 - 2. Operational Test: Verify operation of each lighting control device, and adjust time delays.
- B. Lighting control devices that fail tests and inspections are defective work.

3.6 ADJUSTING

- A. Occupancy Adjustments: When requested within 12 months of date of Substantial Completion, provide on-site assistance in adjusting sensors to suit occupied conditions. Provide up to two visits to Project during other-than-normal occupancy hours for this purpose.

3.7 DEMONSTRATION

- A. Engage a factory-authorized service representative to train Owner's maintenance personnel to adjust, operate, and maintain lighting control devices. Refer to Division 01 Section "Demonstration and Training."

END OF SECTION 260923

SECTION 262413 - SWITCHBOARDS

PART 1 - GENERAL

1.1 RELATED DOCUMENTS

- A. Drawings and general provisions of the Contract, including General and Supplementary Conditions and Division 01 Specification Sections, apply to this Section.

1.2 SUMMARY

- A. Section Includes:
 - 1. Service and distribution switchboards rated 600 V and less.
 - 2. Transient voltage suppression devices.
 - 3. Disconnecting and overcurrent protective devices.
 - 4. Instrumentation.
 - 5. Control power.
 - 6. Accessory components and features.
 - 7. Identification.

1.3 PERFORMANCE REQUIREMENTS

- A. Seismic Performance: Switchboards shall withstand the effects of earthquake motions determined according to SEI/ASCE 7.
 - 1. The term "withstand" means "the unit will remain in place without separation of any parts from the device when subjected to the seismic forces specified and the unit will be fully operational after the seismic event."

1.4 SUBMITTALS

- A. Product Data: For each type of switchboard, overcurrent protective device, transient voltage suppression device, ground-fault protector, accessory, and component indicated. Include dimensions and manufacturers' technical data on features, performance, electrical characteristics, ratings, accessories, and finishes.
- B. Shop Drawings: For each switchboard and related equipment.
 - 1. Include dimensioned plans, elevations, sections, and details, including required clearances and service space around equipment. Show tabulations of installed devices, equipment features, and ratings.
 - 2. Detail enclosure types for types other than NEMA 250, Type 1.
 - 3. Detail bus configuration, current, and voltage ratings.
 - 4. Detail short-circuit current rating of switchboards and overcurrent protective devices.
 - 5. Include descriptive documentation of optional barriers specified for electrical insulation and isolation.
 - 6. Detail features, characteristics, ratings, and factory settings of individual overcurrent protective devices and auxiliary components.
 - 7. Include time-current coordination curves for each type and rating of overcurrent protective device included in switchboards. Submit on translucent log-log graft paper; include selectable ranges for each type of overcurrent protective device.
 - 8. Include schematic and wiring diagrams for power, signal, and control wiring.

- C. Qualification Data: For qualified testing agency.
- D. Seismic Qualification Certificates: Submit certification that switchboards, overcurrent protective devices, accessories, and components will withstand seismic forces defined in Division 26 Section "Noise and Vibration Controls for Electrical Systems." Include the following:
 - 1. Basis for Certification: Indicate whether withstand certification is based on actual test of assembled components or on calculation.
 - 2. Dimensioned Outline Drawings of Equipment Unit: Identify center of gravity and locate and describe mounting and anchorage provisions.
 - 3. Detailed description of equipment anchorage devices on which the certification is based and their installation requirements.
- E. Field Quality-Control Reports:
 - 1. Test procedures used.
 - 2. Test results that comply with requirements.
 - 3. Results of failed tests and corrective action taken to achieve test results that comply with requirements.
- F. Operation and Maintenance Data: For switchboards and components to include in emergency, operation, and maintenance manuals. In addition to items specified in Division 01 Section "Operation and Maintenance Data," include the following:
 - 1. Routine maintenance requirements for switchboards and all installed components.
 - 2. Manufacturer's written instructions for testing and adjusting overcurrent protective devices.
 - 3. Time-current coordination curves for each type and rating of overcurrent protective device included in switchboards. Submit on translucent log-log graft paper; include selectable ranges for each type of overcurrent protective device.

1.5 QUALITY ASSURANCE

- A. Installer Qualifications: An employer of workers qualified as defined in NEMA PB 2.1 and trained in electrical safety as required by NFPA 70E.
- B. Testing Agency Qualifications: Member company of NETA or an NRTL.
 - 1. Testing Agency's Field Supervisor: Currently certified by NETA to supervise on-site testing.
- C. Source Limitations: Obtain switchboards, overcurrent protective devices, components, and accessories from single source from single manufacturer.
- D. Product Selection for Restricted Space: Drawings indicate maximum dimensions for switchboards including clearances between switchboards and adjacent surfaces and other items. Comply with indicated maximum dimensions.
- E. Electrical Components, Devices, and Accessories: Listed and labeled as defined in NFPA 70, by a qualified testing agency, and marked for intended location and application.
- F. Comply with NEMA PB 2.
- G. Comply with NFPA 70.
- H. Comply with UL 891.

1.6 DELIVERY, STORAGE, AND HANDLING

- A. Deliver switchboards in sections or lengths that can be moved past obstructions in delivery path.
- B. Remove loose packing and flammable materials from inside switchboards and install temporary electric heating (250 W per section) to prevent condensation.
- C. Handle and prepare switchboards for installation according to NECA 400.

1.7 PROJECT CONDITIONS

- A. Installation Pathway: Remove and replace access fencing, doors, lift-out panels, and structures to provide pathway for moving switchboards into place.
- B. Environmental Limitations:
 - 1. Do not deliver or install switchboards until spaces are enclosed and weathertight, wet work in spaces is complete and dry, work above switchboards is complete, and temporary HVAC system is operating and maintaining ambient temperature and humidity conditions at occupancy levels during the remainder of the construction period.
 - 2. Rate equipment for continuous operation under the following conditions unless otherwise indicated:
 - a. Ambient Temperature: Not exceeding 104 deg F (40 deg C).
 - b. Altitude: Not exceeding 6600 feet (2000 m).
- C. Service Conditions: NEMA PB 2, usual service conditions, as follows:
 - 1. Ambient temperatures within limits specified.
 - 2. Altitude not exceeding 6600 feet (2000 m).

1.8 COORDINATION

- A. Coordinate layout and installation of switchboards and components with other construction that penetrates walls or is supported by them, including electrical and other types of equipment, raceways, piping, encumbrances to workspace clearance requirements, and adjacent surfaces. Maintain required workspace clearances and required clearances for equipment access doors and panels.
- B. Coordinate sizes and locations of concrete bases with actual equipment provided. Cast anchor-bolt inserts into bases. Concrete, reinforcement, and formwork requirements are specified in Division 03.

1.9 WARRANTY

- A. Special Warranty: Manufacturer's standard form in which manufacturer agrees to repair or replace transient voltage suppression devices that fail in materials or workmanship within specified warranty period.
 - 1. Warranty Period: Five years from date of Substantial Completion.

1.10 EXTRA MATERIALS

- A. Furnish extra materials that match products installed and that are packaged with protective covering for storage and identified with labels describing contents.

1. Potential Transformer Fuses: Equal to 10 percent of quantity installed for each size and type, but no fewer than two of each size and type.
2. Control-Power Fuses: Equal to 10 percent of quantity installed for each size and type, but no fewer than two of each size and type.
3. Indicating Lights: Equal to 10 percent of quantity installed for each size and type, but no fewer than one of each size and type.

PART 2 - PRODUCTS

2.1 MANUFACTURED UNITS

- A. Manufacturers: Subject to compliance with requirements, provide products by one of the following:
 1. Eaton Electrical Inc.; Cutler-Hammer Business Unit.
 2. General Electric Company; GE Consumer & Industrial - Electrical Distribution.
 3. Square D; a brand of Schneider Electric.
- B. Front-Connected, Front-Accessible Switchboards:
 1. Main Devices: Panel mounted.
 2. Branch Devices: Panel mounted.
 3. Sections front and rear aligned.
- C. Nominal System Voltage: 480Y/277 V.
- D. Main-Bus Continuous: As noted on drawings.
- E. Seismic Requirements: Fabricate and test switchboards according to IEEE 344 to withstand seismic forces defined in Division 26 Section "Noise and Vibration Controls for Electrical Systems."
- F. Indoor Enclosures: Steel, NEMA 250, Type 1.
- G. Enclosure Finish for Indoor Units: Factory-applied finish in manufacturer's standard gray finish over a rust-inhibiting primer on treated metal surface.
- H. Barriers: Between adjacent switchboard sections.
- I. Insulation and isolation for main bus of main section and main and vertical buses of feeder sections.
- J. Customer Metering Compartment: A separate customer metering compartment and section with front hinged door, for indicated metering, and current transformers for each meter. Current transformer secondary wiring shall be terminated on shorting-type terminal blocks. Include potential transformers having primary and secondary fuses with disconnecting means and secondary wiring terminated on terminal blocks.
- K. Hinged Front Panels: Allow access to circuit breaker, metering, accessory, and blank compartments.
- L. Buses and Connections: Three phase, four wire unless otherwise indicated.
 1. Phase- and Neutral-Bus Material: Hard-drawn copper of 98 percent conductivity, silver-plated, with tin-plated aluminum or copper feeder circuit-breaker line connections.
 2. Ground Bus: Minimum-size required by UL 891, hard-drawn copper of 98 percent conductivity, equipped with compression connectors for feeder and branch-circuit ground conductors.
 3. Neutral Buses: 100 percent of the ampacity of phase buses unless otherwise indicated, equipped with compression connectors for outgoing circuit neutral cables.

- M. Future Devices: Equip compartments with mounting brackets, supports, bus connections, and appurtenances at full rating of circuit-breaker compartment.

2.2 DISCONNECTING AND OVERCURRENT PROTECTIVE DEVICES

- A. Molded-Case Circuit Breaker (MCCB): Comply with UL 489, with interrupting capacity to meet available fault currents.
 - 1. Thermal-Magnetic Circuit Breakers: Inverse time-current element for low-level overloads, and instantaneous magnetic trip element for short circuits. Adjustable magnetic trip setting for circuit-breaker frame sizes 250 A and larger.
 - 2. Adjustable Instantaneous-Trip Circuit Breakers: Magnetic trip element with front-mounted, field-adjustable trip setting.
 - 3. Electronic trip circuit breakers with rms sensing; field-replaceable rating plug or field-replicable electronic trip; and the following field-adjustable settings:
 - a. Instantaneous trip.
 - b. Long- and short-time pickup levels.
 - c. Long- and short-time time adjustments.
 - d. Ground-fault pickup level, time delay, and I^2t response.
 - 4. Molded-Case Circuit-Breaker (MCCB) Features and Accessories:
 - a. Standard frame sizes, trip ratings, and number of poles.
 - b. Lugs: Compression style, suitable for number, size, trip ratings, and conductor material.
 - c. Ground-Fault Protection: Integrally mounted relay and trip unit with adjustable pickup and time-delay settings, push-to-test feature, and ground-fault indicator.
 - d. Communication Capability: Integral communication module with functions and features compatible with power monitoring and control system specified in Division 26 Section "Electrical Power Monitoring and Control."
 - e. Shunt Trip: 120-V trip coil energized from separate circuit, set to trip at 55 percent of rated voltage.
 - f. Undervoltage Trip: Set to operate at 35 to 75 percent of rated voltage without intentional time delay.
 - g. Auxiliary Contacts: One SPDT switch with "a" and "b" contacts; "a" contacts mimic circuit-breaker contacts, "b" contacts operate in reverse of circuit-breaker contacts.

2.3 INSTRUMENTATION

- A. Instrument Transformers: IEEE C57.13, NEMA EI 21.1, and the following:
 - 1. Potential Transformers: IEEE C57.13; 120 V, 60 Hz, single secondary; disconnecting type with integral fuse mountings. Burden and accuracy shall be consistent with connected metering and relay devices.
 - 2. Current Transformers: IEEE C57.13; 5 A, 60 Hz, secondary; wound type; single secondary winding and secondary shorting device. Burden and accuracy shall be consistent with connected metering and relay devices.
 - 3. Control-Power Transformers: Dry type, mounted in separate compartments for units larger than 3 kVA.
 - 4. Current Transformers for Neutral and Ground-Fault Current Sensing: Connect secondary wiring to ground overcurrent relays, via shorting terminals, to provide selective tripping of main and tie circuit breaker. Coordinate with feeder circuit-breaker, ground-fault protection.
- B. Multifunction Digital-Metering Monitor: Microprocessor-based unit suitable for three- or four-wire systems and with the following features:
 - 1. Switch-selectable digital display of the following values with maximum accuracy tolerances as indicated:

- a. Phase Currents, Each Phase: Plus or minus 1 percent.
- b. Phase-to-Phase Voltages, Three Phase: Plus or minus 1 percent.
- c. Phase-to-Neutral Voltages, Three Phase: Plus or minus 1 percent.
- d. Megawatts: Plus or minus 2 percent.
- e. Megavars: Plus or minus 2 percent.
- f. Power Factor: Plus or minus 2 percent.
- g. Frequency: Plus or minus 0.5 percent.
- h. Accumulated Energy, Megawatt Hours: Plus or minus 2 percent; accumulated values unaffected by power outages up to 72 hours.
- i. Megawatt Demand: Plus or minus 2 percent; demand interval programmable from five to 60 minutes.
- j. Contact devices to operate remote impulse-totalizing demand meter.

2. Mounting: Display and control unit flush or semiflush mounted in instrument compartment door.

2.4 CONTROL POWER

- A. Control Circuits: 120-V ac, supplied through secondary disconnecting devices from control-power transformer.

2.5 ACCESSORY COMPONENTS AND FEATURES

- A. Portable Test Set: For testing functions of solid-state trip devices without removing from switchboard. Include relay and meter test plugs suitable for testing switchboard meters and switchboard class relays.

PART 3 - EXECUTION

3.1 EXAMINATION

- A. Receive, inspect, handle, and store switchboards according to NECA 400.
- B. Examine switchboards before installation. Reject switchboards that are moisture damaged or physically damaged.
- C. Examine elements and surfaces to receive switchboards for compliance with installation tolerances and other conditions affecting performance of the Work.
- D. Proceed with installation only after unsatisfactory conditions have been corrected.

3.2 INSTALLATION

- A. Install switchboards and accessories according to NECA 400 or NEMA PB 2.1 where applicable.
- B. Equipment Mounting: Install switchboards on concrete base, 4-inch (100-mm) nominal thickness.
 1. Install dowel rods to connect concrete base to concrete floor. Unless otherwise indicated, install dowel rods on 18-inch (450-mm) centers around the full perimeter of concrete base.
 2. For supported equipment, install epoxy-coated anchor bolts that extend through concrete base and anchor into structural concrete floor.
 3. Place and secure anchorage devices. Use setting drawings, templates, diagrams, instructions, and directions furnished with items to be embedded.
 4. Install anchor bolts to elevations required for proper attachment to switchboards.

- C. Temporary Lifting Provisions: Remove temporary lifting eyes, channels, and brackets and temporary blocking of moving parts from switchboard units and components.
- D. Comply with mounting and anchoring requirements specified in Division 26 Section "Vibration and Seismic Controls for Electrical Systems."
- E. Operating Instructions: Frame and mount the printed basic operating instructions for switchboards, including control and key interlocking sequences and emergency procedures. Fabricate frame of finished wood or metal and cover instructions with clear acrylic plastic. Mount on front of switchboards.
- F. Install filler plates in unused spaces of panel-mounted sections.
- G. Install overcurrent protective devices, transient voltage suppression devices, and instrumentation.
 - 1. Set field-adjustable switches and circuit-breaker trip ranges.
- H. Comply with NECA 1.

3.3 IDENTIFICATION

- A. Identify field-installed conductors, interconnecting wiring, and components; provide warning signs complying with requirements for identification specified in Division 26 Section "Identification for Electrical Systems."
- B. Switchboard Nameplates: Label each switchboard compartment with a nameplate complying with requirements for identification specified in Division 26 Section "Identification for Electrical Systems."
- C. Device Nameplates: Label each disconnecting and overcurrent protective device and each meter and control device mounted in compartment doors with a nameplate complying with requirements for identification specified in Division 26 Section "Identification for Electrical Systems."

3.4 FIELD QUALITY CONTROL

- A. Perform tests and inspections.
 - 1. Manufacturer's Field Service: Engage a factory-authorized service representative to inspect components, assemblies, and equipment installations, including connections, and to assist in testing.
- B. Acceptance Testing Preparation:
 - 1. Test insulation resistance for each switchboard bus, component, connecting supply, feeder, and control circuit.
 - 2. Test continuity of each circuit.
- C. Tests and Inspections:
 - 1. Perform each visual and mechanical inspection and electrical test stated in NETA Acceptance Testing Specification. Certify compliance with test parameters.
 - 2. Correct malfunctioning units on-site, where possible, and retest to demonstrate compliance; otherwise, replace with new units and retest.
 - 3. Perform the following infrared scan tests and inspections and prepare reports:
 - a. Initial Infrared Scanning: After Substantial Completion, but not more than 60 days after Final Acceptance, perform an infrared scan of each switchboard. Remove front panels so joints and connections are accessible to portable scanner.

- b. Follow-up Infrared Scanning: Perform an additional follow-up infrared scan of each switchboard 11 months after date of Substantial Completion.
 - c. Instruments and Equipment:
 - 1) Use an infrared scanning device designed to measure temperature or to detect significant deviations from normal values. Provide calibration record for device.
 - 4. Test and adjust controls, remote monitoring, and safeties. Replace damaged and malfunctioning controls and equipment.
 - D. Switchboard will be considered defective if it does not pass tests and inspections.
 - E. Prepare test and inspection reports, including a certified report that identifies switchboards included and that describes scanning results. Include notation of deficiencies detected, remedial action taken, and observations after remedial action.
- 3.5 ADJUSTING
- A. Adjust moving parts and operable components to function smoothly, and lubricate as recommended by manufacturer.
 - B. Set field-adjustable circuit-breaker trip ranges as indicated.
- 3.6 PROTECTION
- A. Temporary Heating: Apply temporary heat, to maintain temperature according to manufacturer's written instructions, until switchboard is ready to be energized and placed into service.
- 3.7 DEMONSTRATION
- A. Train Owner's maintenance personnel to adjust, operate, and maintain switchboards, overcurrent protective devices, instrumentation, and accessories, and to use and reprogram microprocessor-based trip, monitoring, and communication units.

END OF SECTION 262413

SECTION 262416 - PANELBOARDS

PART 1 - GENERAL

1.1 RELATED DOCUMENTS

- A. Drawings and general provisions of the Contract, including General and Supplementary Conditions and Division 01 Specification Sections, apply to this Section.

1.2 SUMMARY

- A. Section Includes:
 - 1. Distribution panelboards.
 - 2. Lighting and appliance branch-circuit panelboards.

1.3 PERFORMANCE REQUIREMENTS

- A. Seismic Performance: Panelboards shall withstand the effects of earthquake motions determined according to SEI/ASCE 7.
 - 1. The term "withstand" means "the unit will remain in place without separation of any parts from the device when subjected to the seismic forces specified and the unit will be fully operational after the seismic event."

1.4 SUBMITTALS

- A. Product Data: For each type of panelboard, switching and overcurrent protective device, accessory, and component indicated. Include dimensions and manufacturers' technical data on features, performance, electrical characteristics, ratings, and finishes.
- B. Shop Drawings: For each panelboard and related equipment.
 - 1. Include dimensioned plans, elevations, sections, and details. Show tabulations of installed devices, equipment features, and ratings.
 - 2. Detail enclosure types and details for types other than NEMA 250, Type 1.
 - 3. Detail bus configuration, current, and voltage ratings.
 - 4. Short-circuit current rating of panelboards and overcurrent protective devices.
 - 5. Detail features, characteristics, ratings, and factory settings of individual overcurrent protective devices and auxiliary components.
 - 6. Include wiring diagrams for power, signal, and control wiring.
 - 7. Include time-current coordination curves for each type and rating of adjustable overcurrent protective device included in panelboards. Submit on translucent log-log graft paper; include selectable ranges for each type of overcurrent protective device.
- C. Qualification Data: For qualified testing agency.
- D. Seismic Qualification Certificates: Submit certification that panelboards, overcurrent protective devices, accessories, and components will withstand seismic forces defined in Division 26 Section "Noise and Vibration Controls for Electrical Systems." Include the following:
 - 1. Basis for Certification: Indicate whether withstand certification is based on actual test of assembled components or on calculation.

2. Dimensioned Outline Drawings of Equipment Unit: Identify center of gravity and locate and describe mounting and anchorage provisions.
3. Detailed description of equipment anchorage devices on which the certification is based and their installation requirements.

E. Field Quality-Control Reports:

1. Test procedures used.
2. Test results that comply with requirements.
3. Results of failed tests and corrective action taken to achieve test results that comply with requirements.

F. Panelboard Schedules: For installation in panelboards.

G. Operation and Maintenance Data: For panelboards and components to include in emergency, operation, and maintenance manuals. In addition to items specified in Division 01 Section "Operation and Maintenance Data," include the following:

1. Manufacturer's written instructions for testing and adjusting overcurrent protective devices.
2. Time-current curves, including selectable ranges for each type of overcurrent protective device that allows adjustments.

1.5 QUALITY ASSURANCE

A. Testing Agency Qualifications: Member company of NETA or an NRTL.

1. Testing Agency's Field Supervisor: Currently certified by NETA to supervise on-site testing.

B. Source Limitations: Obtain panelboards, overcurrent protective devices, components, and accessories from single source from single manufacturer.

C. Product Selection for Restricted Space: Drawings indicate maximum dimensions for panelboards including clearances between panelboards and adjacent surfaces and other items. Comply with indicated maximum dimensions.

D. Electrical Components, Devices, and Accessories: Listed and labeled as defined in NFPA 70, by a qualified testing agency, and marked for intended location and application.

E. Comply with NEMA PB 1.

F. Comply with NFPA 70.

1.6 DELIVERY, STORAGE, AND HANDLING

A. Remove loose packing and flammable materials from inside panelboards; install temporary electric heating (250 W per panelboard) to prevent condensation.

B. Handle and prepare panelboards for installation according to NECA 407 or NEMA PB 1 as applicable.

1.7 PROJECT CONDITIONS

A. Environmental Limitations:

1. Do not deliver or install panelboards until spaces are enclosed and weathertight, wet work in spaces is complete and dry, work above panelboards is complete, and temporary HVAC system is

- operating and maintaining ambient temperature and humidity conditions at occupancy levels during the remainder of the construction period.
2. Rate equipment for continuous operation under the following conditions unless otherwise indicated:
 - a. Ambient Temperature: Not exceeding 23 deg F to 104 deg F.
 - b. Altitude: Not exceeding 6600 feet.

B. Service Conditions: NEMA PB 1, usual service conditions, as follows:

1. Ambient temperatures within limits specified.
2. Altitude not exceeding 6600 feet.

1.8 COORDINATION

- A. Coordinate layout and installation of panelboards and components with other construction that penetrates walls or is supported by them, including electrical and other types of equipment, raceways, piping, encumbrances to workspace clearance requirements, and adjacent surfaces. Maintain required workspace clearances and required clearances for equipment access doors and panels.

1.9 WARRANTY

1. Warranty Period: One year from date of Substantial Completion.

1.10 EXTRA MATERIALS

- A. Furnish extra materials that match products installed and that are packaged with protective covering for storage and identified with labels describing contents.
1. Keys: Four spares for each type of panelboard cabinet lock.
 2. Circuit Breakers Including GFCI and Ground Fault Equipment Protection (GFEP) Types: Two spares for each panelboard.

PART 2 - PRODUCTS

2.1 GENERAL REQUIREMENTS FOR PANELBOARDS

- A. Fabricate and test panelboards according to IEEE 344 to withstand seismic forces defined in Division 26 Section "Noise and Vibration Controls for Electrical Systems."
- B. Enclosures: Flush- and surface-mounted cabinets.
1. Rated for environmental conditions at installed location.
 - a. Indoor Dry and Clean Locations: NEMA 250, Type 1.
 - b. Outdoor Locations: NEMA 250, Type 3R.
 - c. Kitchen or Wash-Down Areas: NEMA 250, Type 4X, stainless steel.
 - d. Other Wet or Damp Indoor Locations: NEMA 250, Type 4.
 - e. Indoor Locations Subject to Dust, Falling Dirt, and Dripping Noncorrosive Liquids: NEMA 250, Type 5.
 2. Front: Secured to box with concealed trim clamps. For surface-mounted fronts, match box dimensions; for flush-mounted fronts, overlap box.
 3. Finishes:

- a. Panels and Trim: Steel and galvanized steel, factory finished immediately after cleaning and pretreating with manufacturer's standard two-coat, baked-on finish consisting of prime coat and thermosetting topcoat.
 - b. Back Boxes: Same finish as panels and trim.
4. Directory Card: Inside panelboard door, mounted in metal frame with transparent protective cover.
- C. Incoming Mains Location: Top or Bottom as indicated or required.
- D. Phase, Neutral, and Ground Buses:
1. Material: Hard-drawn copper, 98 percent conductivity.
 2. Equipment Ground Bus: Adequate for feeder and branch-circuit equipment grounding conductors; bonded to box.
 3. Isolated Ground Bus: Adequate for branch-circuit isolated ground conductors; insulated from box.
 4. Extra-Capacity Neutral Bus: Neutral bus rated 200 percent of phase bus and UL listed as suitable for nonlinear loads.
- E. Conductor Connectors: Suitable for use with conductor material and sizes.
1. Material: Hard-drawn copper, 98 percent conductivity.
 2. Main and Neutral Lugs: Mechanical type.
 3. Ground Lugs and Bus-Configured Terminators: Mechanical type.
 4. Feed-Through Lugs: Mechanical type, suitable for use with conductor material. Locate at opposite end of bus from incoming lugs or main device.
 5. Subfeed (Double) Lugs: Mechanical type suitable for use with conductor material.
 6. Gutter-Tap Lugs: Mechanical type suitable for use with conductor material. Locate at same end of bus as incoming lugs or main device.
 7. Extra-Capacity Neutral Lugs: Rated 200 percent of phase lugs mounted on extra-capacity neutral bus.
- F. Future Devices: Mounting brackets, bus connections, filler plates, and necessary appurtenances required for future installation of devices.
- G. Panelboard Short-Circuit Current Rating: Fully rated to interrupt symmetrical short-circuit current available at terminals.

2.2 DISTRIBUTION PANELBOARDS

- A. Manufacturers: Subject to compliance with requirements, provide product indicated on Drawings or comparable product by one of the following:
1. Eaton Electrical Inc.; Cutler-Hammer Business Unit.
 2. General Electric Company; GE Consumer & Industrial - Electrical Distribution.
 3. Square D; a brand of Schneider Electric.
- B. Panelboards: NEMA PB 1, power and feeder distribution type.
- C. Mains: Circuit breaker or Lugs only as indicated on panelboard schedules.
- D. Branch Overcurrent Protective Devices for Circuit-Breaker Frame Sizes Larger Than 125 A: Bolt-on circuit breakers; plug-in circuit breakers where individual positive-locking device requires mechanical release for removal.

2.3 LIGHTING AND APPLIANCE BRANCH-CIRCUIT PANELBOARDS

- A. Manufacturers: Subject to compliance with requirements, provide product indicated on Drawings or comparable product by one of the following:
 - 1. Eaton Electrical Inc.; Cutler-Hammer Business Unit.
 - 2. General Electric Company; GE Consumer & Industrial - Electrical Distribution.
 - 3. Square D; a brand of Schneider Electric.
- B. Panelboards: NEMA PB 1, lighting and appliance branch-circuit type.
- C. Mains: Circuit breaker or lugs only.
- D. Branch Overcurrent Protective Devices: Bolt-on circuit breakers, replaceable without disturbing adjacent units.
- E. Doors: Concealed hinges; secured with flush latch with tumbler lock; keyed alike.

2.4 DISCONNECTING AND OVERCURRENT PROTECTIVE DEVICES

- A. Manufacturers: Subject to compliance with requirements, provide product indicated on Drawings or comparable product by one of the following:
 - 1. Eaton Electrical Inc.; Cutler-Hammer Business Unit.
 - 2. General Electric Company; GE Consumer & Industrial - Electrical Distribution.
 - 3. Square D; a brand of Schneider Electric.
- B. Molded-Case Circuit Breaker (MCCB): Comply with UL 489, with interrupting capacity to meet available fault currents.
 - 1. Thermal-Magnetic Circuit Breakers: Inverse time-current element for low-level overloads, and instantaneous magnetic trip element for short circuits. Adjustable magnetic trip setting for circuit-breaker frame sizes 250 A and larger.
 - 2. Adjustable Instantaneous-Trip Circuit Breakers: Magnetic trip element with front-mounted, field-adjustable trip setting.
 - 3. Electronic trip circuit breakers with rms sensing; field-replaceable rating plug or field-replaceable electronic trip; and the following field-adjustable settings:
 - a. Instantaneous trip.
 - b. Long- and short-time pickup levels.
 - c. Long- and short-time time adjustments.
 - d. Ground-fault pickup level, time delay, and I^2t response.
 - 4. GFCI Circuit Breakers: Single- and two-pole configurations with Class A ground-fault protection (6-mA trip).
 - 5. Ground-Fault Equipment Protection (GFEP) Circuit Breakers: Class B ground-fault protection (30-mA trip).
 - 6. Arc-Fault Circuit Interrupter (AFCI) Circuit Breakers: Comply with UL 1699; 120/240-V, single-pole configuration.
 - 7. Molded-Case Circuit-Breaker (MCCB) Features and Accessories:
 - a. Standard frame sizes, trip ratings, and number of poles.
 - b. Lugs: Mechanical style, suitable for number, size, trip ratings, and conductor materials.
 - c. Application Listing: Appropriate for application; Type SWD for switching fluorescent lighting loads; Type HID for feeding fluorescent and high-intensity discharge (HID) lighting circuits.
 - d. Ground-Fault Protection: Integrally mounted relay and trip unit with adjustable pickup and time-delay settings, push-to-test feature, and ground-fault indicator.
 - e. Shunt Trip: 120-V trip coil energized from separate circuit, set to trip at 75 percent of rated voltage.

- f. Auxiliary Contacts: One SPDT switch with "a" and "b" contacts; "a" contacts mimic circuit-breaker contacts and "b" contacts operate in reverse of circuit-breaker contacts.
- g. Multipole units enclosed in a single housing or factory assembled to operate as a single unit.
- h. Handle Padlocking Device: Fixed attachment, for locking circuit-breaker handle in on or off position.
- i. Handle Clamp: Loose attachment, for holding circuit-breaker handle in on position.

PART 3 - EXECUTION

3.1 EXAMINATION

- A. Receive, inspect, handle, and store panelboards according to NECA 407 or NEMA PB 1.1 as applicable.
- B. Examine panelboards before installation. Reject panelboards that are damaged or rusted or have been subjected to water saturation.
- C. Examine elements and surfaces to receive panelboards for compliance with installation tolerances and other conditions affecting performance of the Work.
- D. Proceed with installation only after unsatisfactory conditions have been corrected.

3.2 INSTALLATION

- A. Install panelboards and accessories according to NECA 407 or NEMA PB 1.1 as applicable.
- B. Temporary Lifting Provisions: Remove temporary lifting eyes, channels, and brackets and temporary blocking of moving parts from panelboards.
- C. Comply with mounting and anchoring requirements specified in Division 26 Section "Vibration and Seismic Controls for Electrical Systems."
- D. Mount top of trim 78 inches (1981 mm) above finished floor unless otherwise indicated, except increase up to a maximum of 90 inches if required by height of panelboard.
- E. Mount panelboard cabinet plumb and rigid without distortion of box. Mount recessed panelboards with fronts uniformly flush with wall finish and mating with back box.
- F. Install overcurrent protective devices and controllers not already factory installed.
 - 1. Set field-adjustable, circuit-breaker trip ranges.
- G. Install filler plates in unused spaces.
- H. Stub four 1-inch empty conduits from each and every panelboard into accessible ceiling space or space designated to be ceiling space in the future. Stub four 1-inch empty conduits into raised floor space or below slab not on grade.
- I. Stub four 1-inch empty conduits (one on each side of each building) from each and every panelboard underground to an accessible spot outside the building for future use. Mark each location with permanent flush in grade marker.
- J. Arrange conductors in gutters into groups and bundle and wrap with wire ties after completing load balancing.
- K. Comply with NECA 1.

3.3 IDENTIFICATION

- A. Identify field-installed conductors, interconnecting wiring, and components; provide warning signs complying with Division 26 Section "Identification for Electrical Systems."
- B. Create a directory to indicate installed circuit loads after balancing panelboard loads; incorporate Owner's final room designations. Obtain approval before installing. Use a computer or typewriter to create directory; handwritten directories are not acceptable.
- C. Panelboard Nameplates: Label each panelboard with a nameplate complying with requirements for identification specified in Division 26 Section "Identification for Electrical Systems."
- D. Device Nameplates: Label each branch circuit device in distribution panelboards with a nameplate complying with requirements for identification specified in Division 26 Section "Identification for Electrical Systems."

3.4 FIELD QUALITY CONTROL

- A. Perform tests and inspections.
 - 1. Manufacturer's Field Service: Engage a factory-authorized service representative to inspect components, assemblies, and equipment installations, including connections, and to assist in testing.
- B. Acceptance Testing Preparation:
 - 1. Test insulation resistance for each panelboard bus, component, connecting supply, feeder, and control circuit.
 - 2. Test continuity of each circuit.
- C. Tests and Inspections:
 - 1. Perform each visual and mechanical inspection and electrical test stated in NETA Acceptance Testing Specification. Certify compliance with test parameters.
 - 2. Correct malfunctioning units on-site, where possible, and retest to demonstrate compliance; otherwise, replace with new units and retest.
 - 3. Perform the following infrared scan tests and inspections and prepare reports:
 - a. Initial Infrared Scanning: After Substantial Completion, but not more than 60 days after Final Acceptance, perform an infrared scan of each panelboard. Remove front panels so joints and connections are accessible to portable scanner.
 - b. Follow-up Infrared Scanning: Perform an additional follow-up infrared scan of each panelboard 11 months after date of Substantial Completion.
 - c. Instruments and Equipment:
 - 1) Use an infrared scanning device designed to measure temperature or to detect significant deviations from normal values. Provide calibration record for device.
- D. Panelboards will be considered defective if they do not pass tests and inspections.
- E. Prepare tests and inspection reports, including a certified report that identifies panelboards included and that describes scanning results. Include notation of deficiencies detected, remedial action taken, and observations after remedial action.

3.5 ADJUSTING

- A. Adjust moving parts and operable components to function smoothly, and lubricate as recommended by manufacturer.
- B. Set field-adjustable circuit-breaker trip ranges as indicated.]

3.6 PROTECTION

- A. Temporary Heating: Apply temporary heat to maintain temperature according to manufacturer's written instructions.

END OF SECTION 262416

SECTION 262726 - WIRING DEVICES

PART 1 - GENERAL

1.1 RELATED DOCUMENTS

- A. Drawings and general provisions of the Contract, including General and Supplementary Conditions and Division 01 Specification Sections, apply to this Section.

1.2 SUMMARY

- A. This Section includes the following:
 - 1. Receptacles, receptacles with integral GFCI, and associated device plates.
 - 2. Twist-locking receptacles.
 - 3. Wall-box motion sensors.
 - 4. Isolated-ground receptacles.
 - 5. Snap switches and wall-box dimmers.
 - 6. Communications outlets.
 - 7. Pendant cord-connector devices.
 - 8. Cord and plug sets.
 - 9. Floor service outlets, and multioutlet assemblies.

1.3 DEFINITIONS

- A. EMI: Electromagnetic interference.
- B. GFCI: Ground-fault circuit interrupter.
- C. Pigtail: Short lead used to connect a device to a branch-circuit conductor.
- D. RFI: Radio-frequency interference.
- E. UTP: Unshielded twisted pair.

1.4 SUBMITTALS

- A. Product Data: For each type of product indicated.
- B. Shop Drawings: List of legends and description of materials and process used for premarking wall plates.
- C. Samples: One for each type of device and wall plate specified, in each color specified.
- D. Field quality-control test reports.
- E. Operation and Maintenance Data: For wiring devices to include in all manufacturers' packing label warnings and instruction manuals that include labeling conditions.

1.5 QUALITY ASSURANCE

- A. Source Limitations: Obtain each type of wiring device and associated wall plate through one source from a single manufacturer. Insofar as they are available, obtain all wiring devices and associated wall plates from a single manufacturer and one source.
- B. Electrical Components, Devices, and Accessories: Listed and labeled as defined in NFPA 70, Article 100, by a testing agency acceptable to authorities having jurisdiction, and marked for intended use.
- C. Comply with NFPA 70.

1.6 COORDINATION

- A. Receptacles for Owner-Furnished Equipment: Match plug configurations.
 - 1. Cord and Plug Sets: Match equipment requirements.

PART 2 - PRODUCTS

2.1 MANUFACTURERS

- A. Manufacturers' Names: Shortened versions (shown in parentheses) of the following manufacturers' names are used in other Part 2 articles:
 - 1. Cooper Wiring Devices; a division of Cooper Industries, Inc. (Cooper).
 - 2. Hubbell Incorporated; Wiring Device-Kellems (Hubbell).
 - 3. Leviton Mfg. Company Inc. (Leviton).
 - 4. Pass & Seymour/Legrand; Wiring Devices & Accessories (Pass & Seymour).

2.2 STRAIGHT BLADE RECEPTACLES

- A. Convenience Receptacles, 125 V, 20 A: Comply with NEMA WD 1, NEMA WD 6 configuration 5-20R, and UL 498.
 - 1. Available Products: Subject to compliance with requirements, products that may be incorporated into the Work include, but are not limited to, the following:
 - a. Cooper; 5351 (single), 5352 (duplex).
 - b. Hubbell; HBL5351 (single), CR5352 (duplex).
 - c. Leviton; 5891 (single), 5352 (duplex).
 - d. Pass & Seymour; 5381 (single), 5352 (duplex).
- B. Isolated-Ground, Duplex Convenience Receptacles, 125 V, 20 A: Comply with NEMA WD 1, NEMA WD 6 configuration 5-20R, and UL 498.
 - 1. Available Products: Subject to compliance with requirements, products that may be incorporated into the Work include, but are not limited to, the following:
 - a. Hubbell; CR 5253IG.
 - b. Leviton; 5362-IG.
 - c. Pass & Seymour; IG6300.
 - 2. Description: Straight blade; equipment grounding contacts shall be connected only to the green grounding screw terminal of the device and with inherent electrical isolation from mounting strap. Isolation shall be integral to receptacle construction and not dependent on removable parts.

2.3 GFCI RECEPTACLES

- A. General Description: Straight blade, non-feed-through type. Comply with NEMA WD 1, NEMA WD 6, UL 498, and UL 943, Class A, and include indicator light that is lighted when device is tripped.
- B. Duplex GFCI Convenience Receptacles, 125 V, 20 A:
 - 1. Available Products: Subject to compliance with requirements, products that may be incorporated into the Work include, but are not limited to, the following:
 - a. Cooper; GF20.
 - b. Pass & Seymour; 2084.
- C. Isolated-Ground, Duplex Convenience Receptacles:
 - 1. Available Products: Subject to compliance with requirements, products that may be incorporated into the Work include, but are not limited to, the following:
 - a. Cooper; IG5362BLS.
 - b. Hubbell; IG5362SA.
 - c. Leviton; 5380-IG.
 - 2. Description: Straight blade, 125 V, 20 A; NEMA WD 6 configuration 5-20R. Equipment grounding contacts shall be connected only to the green grounding screw terminal of the device and with inherent electrical isolation from mounting strap. Isolation shall be integral to receptacle construction and not dependent on removable parts.

2.4 TWIST-LOCKING RECEPTACLES

- A. Single Convenience Receptacles, 125 V, 20 A: Comply with NEMA WD 1, NEMA WD 6 configuration L5-20R, and UL 498.
 - 1. Available Products: Subject to compliance with requirements, products that may be incorporated into the Work include, but are not limited to, the following:
 - a. Cooper; L520R.
 - b. Hubbell; HBL2310.
 - c. Leviton; 2310.
 - d. Pass & Seymour; L520-R.

2.5 PENDANT CORD-CONNECTOR DEVICES

- A. Description: Matching, locking-type plug and receptacle body connector; NEMA WD 6 configurations L5-20P and L5-20R, heavy-duty grade.
 - 1. Body: Nylon with screw-open cable-gripping jaws and provision for attaching external cable grip.
 - 2. External Cable Grip: Woven wire-mesh type made of high-strength galvanized-steel wire strand, matched to cable diameter, and with attachment provision designed for corresponding connector.

2.6 CORD AND PLUG SETS

- A. Description: Match voltage and current ratings and number of conductors to requirements of equipment being connected.
 - 1. Cord: Rubber-insulated, stranded-copper conductors, with Type SOW-A jacket; with green-insulated grounding conductor and equipment-rating ampacity plus a minimum of 30 percent.

2. Plug: Nylon body and integral cable-clamping jaws. Match cord and receptacle type for connection.

2.7 SNAP SWITCHES

- A. Comply with NEMA WD 1 and UL 20.
- B. Switches, 120/277 V, 20 A:
 1. Available Products: Subject to compliance with requirements, products that may be incorporated into the Work include, but are not limited to, the following:
 - a. Cooper; 2221 (single pole), 2222 (two pole), 2223 (three way), 2224 (four way).
 - b. Hubbell; CS1221 (single pole), CS1222 (two pole), CS1223 (three way), CS1224 (four way).
 - c. Leviton; 1221-2 (single pole), 1222-2 (two pole), 1223-2 (three way), 1224-2 (four way).
 - d. Pass & Seymour; 20AC1 (single pole), 20AC2 (two pole), 20AC3 (three way), 20AC4 (four way).
- C. Pilot Light Switches, 20 A:
 1. Available Products: Subject to compliance with requirements, products that may be incorporated into the Work include, but are not limited to, the following:
 - a. Cooper; 2221PL for 120 V and 277 V.
 - b. Hubbell; HPL1221PL for 120 V and 277 V.
 - c. Leviton; 1221-PLR for 120 V, 1221-7PLR for 277 V.
 - d. Pass & Seymour; PS20AC1-PLR for 120 V.
 2. Description: Single pole, with neon-lighted handle, illuminated when switch is "ON."
- D. Key-Operated Switches, 120/277 V, 20 A:
 1. Available Products: Subject to compliance with requirements, products that may be incorporated into the Work include, but are not limited to, the following:
 - a. Cooper; 2221L.
 - b. Hubbell; HBL1221L.
 - c. Leviton; 1221-2L.
 - d. Pass & Seymour; PS20AC1-L.
 2. Description: Single pole, with factory-supplied key in lieu of switch handle.
- E. Single-Pole, Double-Throw, Momentary Contact, Center-Off Switches, 120/277 V, 20 A; for use with mechanically held lighting contactors.
 1. Available Products: Subject to compliance with requirements, products that may be incorporated into the Work include, but are not limited to, the following:
 - a. Cooper; 1995.
 - b. Hubbell; HBL1557.
 - c. Leviton; 1257.
 - d. Pass & Seymour; 1251.
- F. Key-Operated, Single-Pole, Double-Throw, Momentary Contact, Center-Off Switches, 120/277 V, 20 A; for use with mechanically held lighting contactors, with factory-supplied key in lieu of switch handle.
 1. Available Products: Subject to compliance with requirements, products that may be incorporated into the Work include, but are not limited to, the following:

- a. Cooper; 1995L.
- b. Hubbell; HBL1557L.
- c. Leviton; 1257L.
- d. Pass & Seymour; 1251L.

2.8 WALL-BOX DIMMERS

- A. Dimmer Switches: Modular, full-wave, solid-state units with integral, quiet on-off switches, with audible frequency and EMI/RFI suppression filters.
- B. Control: Continuously adjustable slider; with single-pole or three-way switching. Comply with UL 1472.
- C. Incandescent Lamp Dimmers: 120 V; control shall follow square-law dimming curve. On-off switch positions shall bypass dimmer module.
 1. 600 W; dimmers shall require no derating when ganged with other devices.]
- D. Fluorescent Lamp Dimmer Switches: Modular; compatible with dimmer ballasts; trim potentiometer to adjust low-end dimming; dimmer-ballast combination capable of consistent dimming with low end not greater than 5 percent of full brightness.

2.9 OCCUPANCY SENSORS

- A. Wall-Switch Sensors:
 1. Available Products: Subject to compliance with requirements, products that may be incorporated into the Work include, but are not limited to, the following:
 - a. Watt Stopper, The
 - b. Hubbell
 - c. Leviton
 2. Description: Adaptive-technology type, 120/277 V, adjustable time delay up to 20 minutes, 180-degree field of view, with a minimum coverage area of 900 sq. ft. (84 sq. m).
- B. Long-Range Wall-Switch Sensors:
 1. Available Products: Subject to compliance with requirements, products that may be incorporated into the Work include, but are not limited to, the following:
 - a. Watt Stopper (The); DT-200.
 - b. Hubbell
 - c. Leviton
 2. Description: Dual technology, with both passive-infrared- and ultrasonic-type sensing, 120/277 V, adjustable time delay up to 30 minutes, 110-degree field of view, and a minimum coverage area of 1200 sq. ft. (111 sq. m).
- C. Wide-Range Wall-Switch Sensors:
 1. Available Products: Subject to compliance with requirements, products that may be incorporated into the Work include, but are not limited to, the following:
 - a. Watt Stopper (The); CX-100-3.

- b. Hubbell
- c. Leviton

- 2. Description: Passive-infrared type, 120/277 V, adjustable time delay up to 30 minutes, 150-degree field of view, with a minimum coverage area of 1200 sq. ft. (111 sq. m).

2.10 WALL PLATES

- A. Single and combination types to match corresponding wiring devices.
 - 1. Plate-Securing Screws: Metal with head color to match plate finish.
 - 2. Material for Finished Spaces: satin-finished stainless steel 0.04-inch- (1-mm-) thick (oversized).
 - 3. Material for Unfinished Spaces: Galvanized steel.
 - 4. Material for Damp Locations: Cast aluminum with spring-loaded lift cover, and listed and labeled for use in "wet locations."
- B. Wet-Location, Weatherproof Cover Plates: NEMA 250, complying with type 3R weather-resistant die-cast aluminum or thermoplastic with lockable cover.

2.11 FLOOR SERVICE FITTINGS

- A. Type: Modular, flush-type, dual-service units suitable for wiring method used.
- B. Compartments: Barrier separates power from voice and data communication cabling.
- C. Service Plate: Rectangular, die-cast aluminum with satin finish.
- D. Power Receptacle: NEMA WD 6 configuration 5-20R, gray finish, unless otherwise indicated.
- E. Voice and Data Communication Outlet: Two modular, keyed, color-coded, RJ-45 Category 6 jacks for UTP cable.

2.12 MULTIOUTLET ASSEMBLIES

- A. Available Manufacturers: Subject to compliance with requirements, manufacturers offering products that may be incorporated into the Work include, but are not limited to, the following:
 - 1. Hubbell Incorporated; Wiring Device-Kellems.
 - 2. Wiremold Company (The).
- B. Components of Assemblies: Products from a single manufacturer designed for use as a complete, matching assembly of raceways and receptacles.
- C. Raceway Material: Metal, with manufacturer's standard finish.
- D. Wire: No. 12 AWG.

2.13 FINISHES

- A. Color: Wiring device catalog numbers in Section Text do not designate device color.
 - 1. Wiring Devices Connected to Normal Power System: As selected by Architect, unless otherwise indicated or required by NFPA 70 or device listing.
 - 2. Wiring Devices Connected to UPS Power System: Red.

3. Isolated-Ground Receptacles: As specified above, with orange triangle on face.

PART 3 - EXECUTION

3.1 INSTALLATION

- A. Comply with NECA 1, including the mounting heights listed in that standard, unless otherwise noted.
- B. Coordination with Other Trades:
 1. Take steps to insure that devices and their boxes are protected. Do not place wall finish materials over device boxes and do not cut holes for boxes with routers that are guided by riding against outside of the boxes.
 2. Keep outlet boxes free of plaster, drywall joint compound, mortar, cement, concrete, dust, paint, and other material that may contaminate the raceway system, conductors, and cables.
 3. Install device boxes in brick or block walls so that the cover plate does not cross a joint unless the joint is troweled flush with the face of the wall.
 4. Install wiring devices after all wall preparation, including painting, is complete.
- C. Conductors:
 1. Do not strip insulation from conductors until just before they are spliced or terminated on devices.
 2. Strip insulation evenly around the conductor using tools designed for the purpose. Avoid scoring or nicking of solid wire or cutting strands from stranded wire.
 3. The length of free conductors at outlets for devices shall meet provisions of NFPA 70, Article 300, without pigtails.
 4. Existing Conductors:
 - a. Cut back and pigtail, or replace all damaged conductors.
 - b. Straighten conductors that remain and remove corrosion and foreign matter.
 - c. Pigtailing existing conductors is permitted provided the outlet box is large enough.
- D. Device Installation:
 1. Replace all devices that have been in temporary use during construction or that show signs that they were installed before building finishing operations were complete.
 2. Keep each wiring device in its package or otherwise protected until it is time to connect conductors.
 3. Do not remove surface protection, such as plastic film and smudge covers, until the last possible moment.
 4. Connect devices to branch circuits using pigtails that are not less than 6 inches (152 mm) in length.
 5. When there is a choice, use side wiring with binding-head screw terminals. Wrap solid conductor tightly clockwise, 2/3 to 3/4 of the way around terminal screw.
 6. Use a torque screwdriver when a torque is recommended or required by the manufacturer.
 7. When conductors larger than No. 12 AWG are installed on 15- or 20-A circuits, splice No. 12 AWG pigtails for device connections.
 8. Tighten unused terminal screws on the device.
 9. When mounting into metal boxes, remove the fiber or plastic washers used to hold device mounting screws in yokes, allowing metal-to-metal contact.
- E. Receptacle Orientation:
 1. Install ground pin of vertically mounted receptacles down, and on horizontally mounted receptacles to the right.
- F. Device Plates: Do not use oversized or extra-deep plates. Repair wall finishes and remount outlet boxes when standard device plates do not fit flush or do not cover rough wall opening.
- G. Dimmers:

1. Install dimmers within terms of their listing.
2. Verify that dimmers used for fan speed control are listed for that application.
3. Install unshared neutral conductors on line and load side of dimmers according to manufacturers' device listing conditions in the written instructions.

H. Arrangement of Devices: Unless otherwise indicated, mount flush, with long dimension vertical and with grounding terminal of receptacles on top. Group adjacent switches under single, multigang wall plates.

I. Adjust locations of floor service outlets to suit arrangement of partitions and furnishings.

3.2 IDENTIFICATION

A. Comply with Division 26 Section "Identification for Electrical Systems."

1. Receptacles: Identify panelboard and circuit number from which served. Use hot, stamped or engraved machine printing with white-filled lettering on face of plate, and durable wire markers or tags inside outlet boxes.

3.3 FIELD QUALITY CONTROL

A. Perform tests and inspections and prepare test reports.

1. Test Instruments: Use instruments that comply with UL 1436.
2. Test Instrument for Convenience Receptacles: Digital wiring analyzer with digital readout or illuminated LED indicators of measurement.

B. Tests for Convenience Receptacles:

1. Line Voltage: Acceptable range is 105 to 132 V.
2. Percent Voltage Drop under 15-A Load: A value of 6 percent or higher is not acceptable.
3. Ground Impedance: Values of up to 2 ohms are acceptable.
4. GFCI Trip: Test for tripping values specified in UL 1436 and UL 943.
5. Using the test plug, verify that the device and its outlet box are securely mounted.
6. The tests shall be diagnostic, indicating damaged conductors, high resistance at the circuit breaker, poor connections, inadequate fault current path, defective devices, or similar problems. Correct circuit conditions, remove malfunctioning units and replace with new ones, and retest as specified above.

END OF SECTION 262726

SECTION 262813 - FUSES

PART 1 - GENERAL

1.1 RELATED DOCUMENTS

- A. Drawings and general provisions of the Contract, including General and Supplementary Conditions and Division 01 Specification Sections, apply to this Section.

1.2 SUMMARY

- A. Section Includes:
 - 1. Cartridge fuses rated 600-V ac and less for use in control circuits, enclosed switches, and enclosed controllers.
 - 2. Spare-fuse cabinets.

1.3 SUBMITTALS

- A. Product Data: For each type of product indicated. Include construction details, material, dimensions, descriptions of individual components, and finishes for spare-fuse cabinets. Include the following for each fuse type indicated:
 - 1. Ambient Temperature Adjustment Information: If ratings of fuses have been adjusted to accommodate ambient temperatures, provide list of fuses with adjusted ratings.
 - a. For each fuse having adjusted ratings, include location of fuse, original fuse rating, local ambient temperature, and adjusted fuse rating.
 - b. Provide manufacturer's technical data on which ambient temperature adjustment calculations are based.
 - 2. Dimensions and manufacturer's technical data on features, performance, electrical characteristics, and ratings.
- B. Operation and Maintenance Data: For fuses to include in emergency, operation, and maintenance manuals. In addition to items specified in Division 01 Section "Operation and Maintenance Data," include the following:
 - 1. Ambient temperature adjustment information.
 - 2. Current-limitation curves for fuses with current-limiting characteristics.
 - 3. Time-current coordination curves (average melt) and current-limitation curves (instantaneous peak let-through current) for each type and rating of fuse. Submit on translucent log-log graph paper.
 - 4. Coordination charts and tables and related data.

1.4 QUALITY ASSURANCE

- A. Source Limitations: Obtain fuses, for use within a specific product or circuit, from single source from single manufacturer.
- B. Electrical Components, Devices, and Accessories: Listed and labeled as defined in NFPA 70, by a qualified testing agency, and marked for intended location and application.

- C. Comply with NEMA FU 1 for cartridge fuses.
- D. Comply with NFPA 70.

1.5 PROJECT CONDITIONS

- A. Where ambient temperature to which fuses are directly exposed is less than 40 deg F (5 deg C) or more than 100 deg F (38 deg C), apply manufacturer's ambient temperature adjustment factors to fuse ratings.

1.6 COORDINATION

- A. Coordinate fuse ratings with utilization equipment nameplate limitations of maximum fuse size and with system short-circuit current levels.

1.7 EXTRA MATERIALS

- A. Furnish extra materials that match products installed and that are packaged with protective covering for storage and identified with labels describing contents.
 - 1. Fuses: Equal to 10 percent of quantity installed for each size and type, but no fewer than two of each size and type.

PART 2 - PRODUCTS

2.1 MANUFACTURERS

- A. Manufacturers: Subject to compliance with requirements, provide products by one of the following:
 - 1. Cooper Bussmann, Inc.
 - 2. Edison Fuse, Inc.
 - 3. Ferraz Shawmut, Inc.
 - 4. Littelfuse, Inc.

2.2 CARTRIDGE FUSES

- A. Characteristics: NEMA FU 1, nonrenewable cartridge fuses with voltage ratings consistent with circuit voltages.

2.3 SPARE-FUSE CABINET

- A. Characteristics: Wall-mounted steel unit with full-length, recessed piano-hinged door and key-coded cam lock and pull.
 - 1. Size: Adequate for storage of spare fuses specified with 15 percent spare capacity minimum.
 - 2. Finish: Gray, baked enamel.
 - 3. Identification: "SPARE FUSES" in 1-1/2-inch- (38-mm-) high letters on exterior of door.
 - 4. Fuse Pullers: For each size of fuse, where applicable and available, from fuse manufacturer.

PART 3 - EXECUTION

3.1 EXAMINATION

- A. Examine fuses before installation. Reject fuses that are moisture damaged or physically damaged.
- B. Examine holders to receive fuses for compliance with installation tolerances and other conditions affecting performance, such as rejection features.
- C. Examine utilization equipment nameplates and installation instructions. Install fuses of sizes and with characteristics appropriate for each piece of equipment.
- D. Evaluate ambient temperatures to determine if fuse rating adjustment factors must be applied to fuse ratings.
- E. Proceed with installation only after unsatisfactory conditions have been corrected.

3.2 FUSE APPLICATIONS

- A. Cartridge Fuses:
 - 1. Service Entrance: Class RK1, time delay.
 - 2. Feeders: Class RK1, time delay.
 - 3. Motor Branch Circuits: Class RK1, time delay.
 - 4. Other Branch Circuits: Class RK1, time delay] or Class RK5, time delay.
 - 5. Control Circuits: Class CC, time delay.

3.3 INSTALLATION

- A. Install fuses in fusible devices. Arrange fuses so rating information is readable without removing fuse.
- B. Install spare-fuse cabinet(s).

3.4 IDENTIFICATION

- A. Install labels complying with requirements for identification specified in Division 26 Section "Identification for Electrical Systems" and indicating fuse replacement information on inside door of each fused switch and adjacent to each fuse block, socket, and holder.

END OF SECTION 262813

SECTION 262816 - ENCLOSED SWITCHES AND CIRCUIT BREAKERS

PART 1 - GENERAL

1.1 RELATED DOCUMENTS

- A. Drawings and general provisions of the Contract, including General and Supplementary Conditions and other Division 01 Specification Sections, apply to this Section.

1.2 SUMMARY

- A. Section Includes:
 - 1. Fusible switches.
 - 2. Nonfusible switches.
 - 3. Molded-case circuit breakers (MCCBs).
 - 4. Enclosures.

1.3 DEFINITIONS

- A. NC: Normally closed.
- B. NO: Normally open.
- C. SPDT: Single pole, double throw.

1.4 PERFORMANCE REQUIREMENTS

- A. Seismic Performance: Enclosed switches and circuit breakers shall withstand the effects of earthquake motions determined according to ASCE/SEI 7.
 - 1. The term "withstand" means "the unit will remain in place without separation of any parts from the device when subjected to the seismic forces specified and the unit will be fully operational after the seismic event."

1.5 SUBMITTALS

- A. Product Data: For each type of enclosed switch, circuit breaker, accessory, and component indicated. Include dimensioned elevations, sections, weights, and manufacturers' technical data on features, performance, electrical characteristics, ratings, accessories, and finishes.
 - 1. Enclosure types and details for types other than NEMA 250, Type 1.
 - 2. Current and voltage ratings.
 - 3. Short-circuit current ratings (interrupting and withstand, as appropriate).
 - 4. Detail features, characteristics, ratings, and factory settings of individual overcurrent protective devices, accessories, and auxiliary components.
 - 5. Include time-current coordination curves (average melt) for each type and rating of overcurrent protective device; include selectable ranges for each type of overcurrent protective device.
- B. Shop Drawings: For enclosed switches and circuit breakers. Include plans, elevations, sections, details, and attachments to other work.

1. Wiring Diagrams: For power, signal, and control wiring.
 - C. Qualification Data: For qualified testing agency.
 - D. Seismic Qualification Certificates: For enclosed switches and circuit breakers, accessories, and components, from manufacturer.
 1. Basis for Certification: Indicate whether withstand certification is based on actual test of assembled components or on calculation.
 2. Dimensioned Outline Drawings of Equipment Unit: Identify center of gravity and locate and describe mounting and anchorage provisions.
 3. Detailed description of equipment anchorage devices on which the certification is based and their installation requirements.
 - E. Field quality-control reports.
 1. Test procedures used.
 2. Test results that comply with requirements.
 3. Results of failed tests and corrective action taken to achieve test results that comply with requirements.
 - F. Manufacturer's field service report.
 - G. Operation and Maintenance Data: For enclosed switches and circuit breakers to include in emergency, operation, and maintenance manuals. In addition to items specified in Division 01 Section "Operation and Maintenance Data," include the following:
 1. Manufacturer's written instructions for testing and adjusting enclosed switches and circuit breakers.
 2. Time-current coordination curves (average melt) for each type and rating of overcurrent protective device; include selectable ranges for each type of overcurrent protective device.
- 1.6 QUALITY ASSURANCE
- A. Source Limitations: Obtain enclosed switches and circuit breakers, overcurrent protective devices, components, and accessories, within same product category, from single source from single manufacturer.
 - B. Product Selection for Restricted Space: Drawings indicate maximum dimensions for enclosed switches and circuit breakers, including clearances between enclosures, and adjacent surfaces and other items. Comply with indicated maximum dimensions.
 - C. Electrical Components, Devices, and Accessories: Listed and labeled as defined in NFPA 70, by a qualified testing agency, and marked for intended location and application.
 - D. Comply with NFPA 70.
- 1.7 PROJECT CONDITIONS
- A. Environmental Limitations: Rate equipment for continuous operation under the following conditions unless otherwise indicated:
 1. Ambient Temperature: Not less than minus 22 deg F (minus 30 deg C) and not exceeding 104 deg F (40 deg C).
 2. Altitude: Not exceeding 6600 feet (2010 m).

1.8 COORDINATION

- A. Coordinate layout and installation of switches, circuit breakers, and components with equipment served and adjacent surfaces. Maintain required workspace clearances and required clearances for equipment access doors and panels.

1.9 EXTRA MATERIALS

- A. Furnish extra materials that match products installed and that are packaged with protective covering for storage and identified with labels describing contents.
 - 1. Fuses: Equal to 10 percent of quantity installed for each size and type, but no fewer than three of each size and type.
 - 2. Fuse Pullers: Two for each size and type.

PART 2 - PRODUCTS

2.1 FUSIBLE SWITCHES

- A. Manufacturers: Subject to compliance with requirements, provide products by one of the following:
 - 1. Eaton Electrical Inc.; Cutler-Hammer Business Unit.
 - 2. General Electric Company; GE Consumer & Industrial - Electrical Distribution.
 - 3. Square D; a brand of Schneider Electric.
- B. Type HD, Heavy Duty, Single Throw, 240 or 600-V ac, 1200 A and Smaller: UL 98 and NEMA KS 1, horsepower rated, with clips or bolt pads to accommodate indicated fuses, lockable handle with capability to accept three padlocks, and interlocked with cover in closed position.
- C. Accessories:
 - 1. Equipment Ground Kit: Internally mounted and labeled for copper and aluminum ground conductors.
 - 2. Neutral Kit: Internally mounted; insulated, capable of being grounded and bonded; labeled for copper and aluminum neutral conductors.
 - 3. Isolated Ground Kit: Internally mounted; insulated, capable of being grounded and bonded; labeled for copper and aluminum neutral conductors.
 - 4. Class R Fuse Kit: Provides rejection of other fuse types when Class R fuses are specified.
 - 5. Auxiliary Contact Kit: One NO/NC (Form "C") auxiliary contact(s), arranged to activate before switch blades open.
 - 6. Lugs: Mechanical type, suitable for number, size, and conductor material.
 - 7. Service-Rated Switches: Labeled for use as service equipment.

2.2 NONFUSIBLE SWITCHES

- A. Manufacturers: Subject to compliance with requirements, provide products by one of the following:
 - 1. Eaton Electrical Inc.; Cutler-Hammer Business Unit.
 - 2. General Electric Company; GE Consumer & Industrial - Electrical Distribution.
 - 3. Square D; a brand of Schneider Electric.
- B. Type HD, Heavy Duty, Single Throw, 240 or 600-V ac, 1200 A and Smaller: UL 98 and NEMA KS 1, horsepower rated, lockable handle with capability to accept three padlocks, and interlocked with cover in closed position.

C. Accessories:

1. Equipment Ground Kit: Internally mounted and labeled for copper and aluminum ground conductors.
2. Neutral Kit: Internally mounted; insulated, capable of being grounded and bonded; labeled for copper and aluminum neutral conductors.
3. Isolated Ground Kit: Internally mounted; insulated, capable of being grounded and bonded; labeled for copper and aluminum neutral conductors.
4. Auxiliary Contact Kit: One NO/NC (Form "C") auxiliary contact(s), arranged to activate before switch blades open.
5. Lugs: Mechanical type, suitable for number, size, and conductor material.

2.3 ENCLOSURES

- A. Enclosed Switches and Circuit Breakers: NEMA AB 1, NEMA KS 1, NEMA 250, and UL 50, to comply with environmental conditions at installed location.
1. Indoor, Dry and Clean Locations: NEMA 250, Type 1.
 2. Outdoor Locations: NEMA 250, Type 3R.
 3. Kitchen or Wash-Down Areas: NEMA 250, Type 4X stainless steel.
 4. Other Wet or Damp, Indoor Locations: NEMA 250, Type 4.
 5. Indoor Locations Subject to Dust, Falling Dirt, and Dripping Noncorrosive Liquids: NEMA 250, Type 12.

PART 3 - EXECUTION

3.1 EXAMINATION

- A. Examine elements and surfaces to receive enclosed switches and circuit breakers for compliance with installation tolerances and other conditions affecting performance of the Work.
- B. Proceed with installation only after unsatisfactory conditions have been corrected.

3.2 INSTALLATION

- A. Install individual wall-mounted switches and circuit breakers with tops at uniform height unless otherwise indicated.
- B. Comply with mounting and anchoring requirements specified in Division 26 Section "Vibration and Seismic Controls for Electrical Systems."
- C. Temporary Lifting Provisions: Remove temporary lifting eyes, channels, and brackets and temporary blocking of moving parts from enclosures and components.
- D. Install fuses in fusible devices.
- E. Comply with NECA 1.

3.3 IDENTIFICATION

- A. Comply with requirements in Division 26 Section "Identification for Electrical Systems."
1. Identify field-installed conductors, interconnecting wiring, and components; provide warning signs.
 2. Label each enclosure with engraved metal or laminated-plastic nameplate.

3.4 FIELD QUALITY CONTROL

- A. Perform tests and inspections.
 - 1. **Manufacturer's Field Service:** Engage a factory-authorized service representative to inspect components, assemblies, and equipment installations, including connections, and to assist in testing.
- B. **Acceptance Testing Preparation:**
 - 1. Test insulation resistance for each enclosed switch and circuit breaker, component, connecting supply, feeder, and control circuit.
 - 2. Test continuity of each circuit.
- C. **Tests and Inspections:**
 - 1. Perform each visual and mechanical inspection and electrical test stated in NETA Acceptance Testing Specification. Certify compliance with test parameters.
 - 2. Correct malfunctioning units on-site, where possible, and retest to demonstrate compliance; otherwise, replace with new units and retest.
 - 3. Perform the following infrared scan tests and inspections and prepare reports:
 - a. **Initial Infrared Scanning:** After Substantial Completion, but not more than 60 days after Final Acceptance, perform an infrared scan of each enclosed switch and circuit breaker. Remove front panels so joints and connections are accessible to portable scanner.
 - b. **Follow-up Infrared Scanning:** Perform an additional follow-up infrared scan of each enclosed switch and circuit breaker 11 months after date of Substantial Completion.
 - c. **Instruments and Equipment:** Use an infrared scanning device designed to measure temperature or to detect significant deviations from normal values. Provide calibration record for device.
 - 4. Test and adjust controls, remote monitoring, and safeties. Replace damaged and malfunctioning controls and equipment.
- D. Enclosed switches and circuit breakers will be considered defective if they do not pass tests and inspections.
- E. Prepare tests and inspection reports, including a certified report that identifies enclosed switches and circuit breakers and that describes scanning results. Include notation of deficiencies detected, remedial action taken, and observations after remedial action.

3.5 ADJUSTING

- A. Adjust moving parts and operable components to function smoothly, and lubricate as recommended by manufacturer.

END OF SECTION 262816

SECTION 262913 - ENCLOSED CONTROLLERS

PART 1 - GENERAL

1.1 RELATED DOCUMENTS

- A. Drawings and general provisions of the Contract, including General and Supplementary Conditions and Division 01 Specification Sections, apply to this Section.

1.2 SUMMARY

- A. Section includes the following enclosed controllers rated 600 V and less:
 - 1. Full-voltage manual.
 - 2. Full-voltage magnetic.

1.3 DEFINITIONS

- A. CPT: Control power transformer.
- B. MCCB: Molded-case circuit breaker.
- C. MCP: Motor circuit protector.
- D. N.C.: Normally closed.
- E. N.O.: Normally open.
- F. OCPD: Overcurrent protective device.

1.4 PERFORMANCE REQUIREMENTS

- A. Seismic Performance: Enclosed controllers shall withstand the effects of earthquake motions determined according to ASCE/SEI 7.
 - 1. The term "withstand" means "the unit will remain in place without separation of any parts from the device when subjected to the seismic forces specified and the unit will be fully operational after the seismic event."

1.5 SUBMITTALS

- A. Product Data: For each type of enclosed controller. Include manufacturer's technical data on features, performance, electrical characteristics, ratings, and enclosure types and finishes.
- B. Shop Drawings: For each enclosed controller. Include dimensioned plans, elevations, sections, details, and required clearances and service spaces around controller enclosures.
 - 1. Show tabulations of the following:
 - a. Each installed unit's type and details.
 - b. Factory-installed devices.

- c. Nameplate legends.
 - d. Short-circuit current rating of integrated unit.
 - e. Features, characteristics, ratings, and factory settings of individual OCPDs in combination controllers.
 - 2. Wiring Diagrams: For power, signal, and control wiring.
 - C. Qualification Data: For qualified testing agency.
 - D. Seismic Qualification Certificates: For enclosed controllers, accessories, and components, from manufacturer.
 - 1. Basis for Certification: Indicate whether withstand certification is based on actual test of assembled components or on calculation.
 - 2. Dimensioned Outline Drawings of Equipment Unit: Identify center of gravity and locate and describe mounting and anchorage provisions.
 - 3. Detailed description of equipment anchorage devices on which the certification is based and their installation requirements.
 - E. Field quality-control reports.
 - F. Operation and Maintenance Data: For enclosed controllers to include in emergency, operation, and maintenance manuals. In addition to items specified in Division 01 Section "Operation and Maintenance Data," include the following:
 - 1. Routine maintenance requirements for enclosed controllers and installed components.
 - 2. Manufacturer's written instructions for testing and adjusting circuit breaker and MCP trip settings.
 - 3. Manufacturer's written instructions for setting field-adjustable overload relays.
 - G. Load-Current and Overload-Relay Heater List: Compile after motors have been installed, and arrange to demonstrate that selection of heaters suits actual motor nameplate full-load currents.
 - H. Load-Current and List of Settings of Adjustable Overload Relays: Compile after motors have been installed, and arrange to demonstrate that switch settings for motor running overload protection suit actual motors to be protected.
- 1.6 QUALITY ASSURANCE
- A. Electrical Components, Devices, and Accessories: Listed and labeled as defined in NFPA 70, by a qualified testing agency, and marked for intended location and application.
 - B. Comply with NFPA 70.
 - C. IEEE Compliance: Fabricate and test enclosed controllers according to IEEE 344 to withstand seismic forces defined in Division 26 Section "Vibration and Seismic Controls for Electrical Systems."
- 1.7 DELIVERY, STORAGE, AND HANDLING
- A. Store enclosed controllers indoors in clean, dry space with uniform temperature to prevent condensation. Protect enclosed controllers from exposure to dirt, fumes, water, corrosive substances, and physical damage.
 - B. If stored in areas subject to weather, cover enclosed controllers to protect them from weather, dirt, dust, corrosive substances, and physical damage. Remove loose packing and flammable materials from inside controllers; install temporary electric heating, with at least 250 W per controller.

1.8 PROJECT CONDITIONS

- A. Environmental Limitations: Rate equipment for continuous operation under the following conditions unless otherwise indicated:
1. Ambient Temperature: Not less than minus 22 deg F (minus 30 deg C) and not exceeding 104 deg F (40 deg C).
 2. Altitude: Not exceeding 6600 feet (2010 m).

1.9 COORDINATION

- A. Coordinate layout and installation of enclosed controllers with other construction including conduit, piping, equipment, and adjacent surfaces. Maintain required workspace clearances and required clearances for equipment access doors and panels.

1.10 EXTRA MATERIALS

- A. Furnish extra materials that match products installed and that are packaged with protective covering for storage and identified with labels describing contents.
1. Fuses for Fused Switches: Equal to 10 percent of quantity installed for each size and type, but no fewer than three of each size and type.
 2. Control Power Fuses: Equal to 10 percent of quantity installed for each size and type, but no fewer than two of each size and type.
 3. Indicating Lights: Two of each type and color installed.
 4. Auxiliary Contacts: Furnish one spare(s) for each size and type of magnetic controller installed.
 5. Power Contacts: Furnish three spares for each size and type of magnetic contactor installed.
 6. Control Power Transformers: Furnish two spares for each size and type of magnetic controller installed.

PART 2 - PRODUCTS

2.1 FULL-VOLTAGE CONTROLLERS

- A. General Requirements for Full-Voltage Controllers: Comply with NEMA ICS 2, general purpose, Class A.
- B. Motor-Starting Switches: "Quick-make, quick-break" toggle or push-button action; marked to show whether unit is off or on.
1. Manufacturers: Subject to compliance with requirements, provide products by one of the following:
 - a. Eaton Electrical Inc.; Cutler-Hammer Business Unit.
 - b. General Electric Company; GE Consumer & Industrial - Electrical Distribution.
 - c. Rockwell Automation, Inc.; Allen-Bradley brand.
 - d. Square D; a brand of Schneider Electric.
 2. Configuration: Nonreversing.
 3. Surface mounting.
 4. One red pilot light.
- C. Fractional Horsepower Manual Controllers: "Quick-make, quick-break" toggle or push-button action; marked to show whether unit is off, on, or tripped.
1. Manufacturers: Subject to compliance with requirements, provide products by one of the following:

- a. Eaton Electrical Inc.; Cutler-Hammer Business Unit.
 - b. General Electric Company; GE Consumer & Industrial - Electrical Distribution.
 - c. Rockwell Automation, Inc.; Allen-Bradley brand.
 - d. Square D; a brand of Schneider Electric.
2. Configuration: Nonreversing.
 3. Overload Relays: Inverse-time-current characteristics; NEMA ICS 2, Class 10 tripping characteristics; heaters matched to nameplate full-load current of actual protected motor; external reset push button; bimetallic type.
 4. Flush or Surface mounting as appropriate.
 5. Red pilot light.
- D. Integral Horsepower Manual Controllers: "Quick-make, quick-break" toggle or push-button action; marked to show whether unit is off, on, or tripped.
1. Manufacturers: Subject to compliance with requirements, provide product indicated on Drawings or comparable product by one of the following:
 - a. Eaton Electrical Inc.; Cutler-Hammer Business Unit.
 - b. General Electric Company; GE Consumer & Industrial - Electrical Distribution.
 - c. Rockwell Automation, Inc.; Allen-Bradley brand.
 - d. Square D; a brand of Schneider Electric.
 2. Configuration: Nonreversing.
 3. Overload Relays: Inverse-time-current characteristics; NEMA ICS 2, Class 10 tripping characteristics; heaters and sensors in each phase, matched to nameplate full-load current of actual protected motor and having appropriate adjustment for duty cycle; external reset push button; bimetallic type.
 4. Flush or Surface mounting as appropriate.
 5. Red pilot light.
 6. One N.O. and one N.C. auxiliary contact.
- E. Magnetic Controllers: Full voltage, across the line, electrically held.
1. Manufacturers: Subject to compliance with requirements, provide product indicated on Drawings or comparable product by one of the following:
 - a. Eaton Electrical Inc.; Cutler-Hammer Business Unit.
 - b. General Electric Company; GE Consumer & Industrial - Electrical Distribution.
 - c. Rockwell Automation, Inc.; Allen-Bradley brand.
 - d. Square D; a brand of Schneider Electric.
 2. Configuration: Nonreversing.
 3. Contactor Coils: Pressure-encapsulated type with coil transient suppressors.
 - a. Operating Voltage: Depending on contactor NEMA size and line-voltage rating, manufacturer's standard matching control power or line voltage.
 4. Power Contacts: Totally enclosed, double-break, silver-cadmium oxide; assembled to allow inspection and replacement without disturbing line or load wiring.
 5. Control Circuits: 120-V ac; obtained from integral CPT, with primary and secondary fuses, with CPT of sufficient capacity to operate integral devices and remotely located pilot, indicating, and control devices.
 - a. CPT Spare Capacity: 50 VA.
 6. Solid-State Overload Relay:
 - a. Switch or dial selectable for motor running overload protection.
 - b. Sensors in each phase.
 - c. Class 10/20 selectable tripping characteristic selected to protect motor against voltage and current unbalance and single phasing.

7. N.C. and N.O., isolated overload alarm contact.
8. External overload reset push button.

- F. Combination Magnetic Controller: Factory-assembled combination of magnetic controller, OCPD, and disconnecting means.
1. Manufacturers: Subject to compliance with requirements, provide product indicated on Drawings or comparable product by one of the following:
 - a. Eaton Electrical Inc.; Cutler-Hammer Business Unit.
 - b. General Electric Company; GE Consumer & Industrial - Electrical Distribution.
 - c. Rockwell Automation, Inc.; Allen-Bradley brand.
 - d. Square D; a brand of Schneider Electric.
 2. Fusible Disconnecting Means:
 - a. NEMA KS 1, heavy-duty, horsepower-rated, fusible switch with clips or bolt pads to accommodate Class R fuses.
 - b. Lockable Handle: Accepts three padlocks and interlocks with cover in closed position.
 3. Auxiliary Contacts: Two N.O./Two N.C., arranged to activate before switch blades open.
 - a. Auxiliary Contacts: N.O./N.C., arranged to activate before switch blades open.

2.2 ENCLOSURES

- A. Enclosed Controllers: NEMA ICS 6, to comply with environmental conditions at installed location.
1. Dry and Clean Indoor Locations: Type 1.
 2. Outdoor Locations: Type 3R.
 3. Kitchen or Wash-Down Areas: Type 4X, stainless steel.
 4. Other Wet or Damp Indoor Locations: Type 4.
 5. Indoor Locations Subject to Dust, Falling Dirt, and Dripping Noncorrosive Liquids: Type 12.

2.3 ACCESSORIES

- A. General Requirements for Control Circuit and Pilot Devices: NEMA ICS 5; factory installed in controller enclosure cover unless otherwise indicated.
1. Push Buttons, Pilot Lights, and Selector Switches: Heavy-duty, oiltight type.
 - a. Push Buttons: Recessed types; momentary as indicated.
 - b. Pilot Lights: LED types; colors as indicated; push to test.
 - c. Selector Switches: Rotary HOA type.
- B. Reversible N.C./N.O. auxiliary contact(s).
- C. Control Relays: Auxiliary and adjustable solid-state time-delay relays.
- D. Phase-Failure, Phase-Reversal, and Undervoltage and Overvoltage Relays: Solid-state sensing circuit with isolated output contacts for hard-wired connections. Provide adjustable undervoltage, overvoltage, and time-delay settings.
- E. Breather and drain assemblies, to maintain interior pressure and release condensation in Type 4, Type 4X, and Type 7 enclosures installed outdoors or in unconditioned interior spaces subject to humidity and temperature swings.

- F. Space heaters, with N.C. auxiliary contacts, to mitigate condensation in Type 3R, Type 4X, and Type 12 enclosures installed outdoors or in unconditioned interior spaces subject to humidity and temperature swings.
- G. Sun shields installed on fronts, sides, and tops of enclosures installed outdoors and subject to direct and extended sun exposure.
- H. Cover gaskets for Type 1 enclosures.
- I. 10% spare control wiring terminal blocks; unwired.

PART 3 - EXECUTION

3.1 EXAMINATION

- A. Examine areas and surfaces to receive enclosed controllers, with Installer present, for compliance with requirements and other conditions affecting performance of the Work.
- B. Examine enclosed controllers before installation. Reject enclosed controllers that are wet, moisture damaged, or mold damaged.
- C. Proceed with installation only after unsatisfactory conditions have been corrected.

3.2 INSTALLATION

- A. Wall-Mounted Controllers: Install enclosed controllers on walls with tops at uniform height unless otherwise indicated, and by bolting units to wall or mounting on lightweight structural-steel channels bolted to wall. For controllers not at walls, provide freestanding racks complying with Division 26 Section "Hangers and Supports for Electrical Systems."
- B. Seismic Bracing: Comply with requirements specified in Division 26 Section "Vibration and Seismic Controls for Electrical Systems."
- C. Temporary Lifting Provisions: Remove temporary lifting eyes, channels, and brackets and temporary blocking of moving parts from enclosures and components.
- D. Install fuses in each fusible-switch enclosed controller.
- E. Install fuses in control circuits if not factory installed. Comply with requirements in Division 26 Section "Fuses."
- F. Install heaters in thermal overload relays. Select heaters based on actual nameplate full-load amperes after motors have been installed.
- G. Install, connect, and fuse thermal-protector monitoring relays furnished with motor-driven equipment.
- H. Comply with NECA 1.

3.3 IDENTIFICATION

- A. Identify enclosed controllers, components, and control wiring. Comply with requirements for identification specified in Division 26 Section "Identification for Electrical Systems."
 - 1. Identify field-installed conductors, interconnecting wiring, and components; provide warning signs.

2. Label each enclosure with engraved nameplate.
3. Label each enclosure-mounted control and pilot device.

3.4 CONTROL WIRING INSTALLATION

- A. Install wiring between enclosed controllers and remote devices. Comply with requirements in Division 26 Section "Control-Voltage Electrical Power Cables."
- B. Bundle, train, and support wiring in enclosures.
- C. Connect selector switches and other automatic-control selection devices where applicable.
 1. Connect selector switches to bypass only those manual- and automatic-control devices that have no safety functions when switch is in manual-control position.
 2. Connect selector switches with enclosed-controller circuit in both manual and automatic positions for safety-type control devices such as low and high-pressure cutouts, high-temperature cutouts, and motor overload protectors.

3.5 FIELD QUALITY CONTROL

- A. Perform tests and inspections.
 1. Manufacturer's Field Service: Engage a factory-authorized service representative to inspect components, assemblies, and equipment installations, including connections, and to assist in testing.
- B. Acceptance Testing Preparation:
 1. Test insulation resistance for each enclosed controller, component, connecting supply, feeder, and control circuit.
 2. Test continuity of each circuit.
- C. Tests and Inspections:
 1. Inspect controllers, wiring, components, connections, and equipment installation. **Test** and adjust controllers, components, and equipment.
 2. Test insulation resistance for each enclosed-controller element, component, connecting motor supply, feeder, and control circuits.
 3. Test continuity of each circuit.
 4. Verify that voltages at controller locations are within plus or minus 10 percent of motor nameplate rated voltages. If outside this range for any motor, notify Architect before starting the motor(s).
 5. Test each motor for proper phase rotation.
 6. Perform each electrical test and visual and mechanical inspection stated in NETA Acceptance Testing Specification. Certify compliance with test parameters.
 7. Correct malfunctioning units on-site, where possible, and retest to demonstrate compliance; otherwise, replace with new units and retest.
 8. Perform the following infrared (thermographic) scan tests and inspections and prepare reports:
 - a. Initial Infrared Scanning: After Substantial Completion, but not more than 60 days after Final Acceptance, perform an infrared scan of each multi-pole enclosed controller. Remove front panels so joints and connections are accessible to portable scanner.
 - b. Follow-up Infrared Scanning: Perform an additional follow-up infrared scan of each multi-pole enclosed controller 11 months after date of Substantial Completion.
 - c. Instruments and Equipment: Use an infrared scanning device designed to measure temperature or to detect significant deviations from normal values. Provide calibration record for device.

9. Test and adjust controls, remote monitoring, and safeties. Replace damaged and malfunctioning controls and equipment.

D. Enclosed controllers will be considered defective if they do not pass tests and inspections.

E. Prepare tests and inspection reports including a certified report that identifies enclosed controllers and that describes scanning results. Include notation of deficiencies detected, remedial action taken, and observations after remedial action.

3.6 ADJUSTING

A. Set field-adjustable switches, auxiliary relays, time-delay relays, timers, and overload-relay pickup and trip ranges.

B. Adjust overload-relay heaters or settings if power factor correction capacitors are connected to the load side of the overload relays.

C. Adjust the trip settings of MCPs and thermal-magnetic circuit breakers with adjustable instantaneous trip elements. Initially adjust to six times the motor nameplate full-load ampere ratings and attempt to start motors several times, allowing for motor cool down between starts. If tripping occurs on motor inrush, adjust settings in increments until motors start without tripping. Do not exceed eight times the motor full-load amperes (or 11 times for NEMA Premium Efficient motors if required). Where these maximum settings do not allow starting of a motor, notify Architect before increasing settings.

D. Set field-adjustable circuit-breaker trip ranges.

3.7 PROTECTION

A. Temporary Heating: Apply temporary heat to maintain temperature according to manufacturer's written instructions until enclosed controllers are ready to be energized and placed into service.

B. Replace controllers whose interiors have been exposed to water or other liquids prior to Substantial Completion.

3.8 DEMONSTRATION

A. Engage a factory-authorized service representative to train Owner's maintenance personnel to adjust, operate, and maintain enclosed controllers.

END OF SECTION 262913

SECTION 265100 - INTERIOR LIGHTING

PART 1 - GENERAL

1.1 RELATED DOCUMENTS

- A. Drawings and general provisions of the Contract, including General and Supplementary Conditions and Division 01 Specification Sections, apply to this Section.

1.2 SUMMARY

- A. This Section includes the following:

1. Interior lighting fixtures, lamps, and ballasts.
2. Emergency lighting units.
3. Exit signs.
4. Lighting fixture supports.

- B. Related Sections include the following:

1. Division 26 Section "Lighting Control Devices" for automatic control of lighting, including time switches, photoelectric relays, occupancy sensors, and multipole lighting relays and contactors.
2. Division 26 Section "Wiring Devices" for manual wall-box dimmers for incandescent lamps.

1.3 DEFINITIONS

- A. BF: Ballast factor.
- B. CRI: Color-rendering index.
- C. CU: Coefficient of utilization.
- D. HID: High-intensity discharge.
- E. LER: Luminaire efficacy rating.
- F. Luminaire: Complete lighting fixture, including ballast housing if provided.
- G. RCR: Room cavity ratio.

1.4 SUBMITTALS

- A. Product Data: For each type of lighting fixture, arranged in order of fixture designation. Include data on features, accessories, finishes, and the following:
 1. Physical description of lighting fixture including dimensions.
 2. Emergency lighting units including battery and charger.
 3. Ballast.
 4. Energy-efficiency data.
 5. Life, output, and energy-efficiency data for lamps.

6. Photometric data, in IESNA format, in both printed and magnetic text file form, based on laboratory tests of each lighting fixture type, outfitted with lamps, ballasts, and accessories identical to those indicated for the lighting fixture as applied in this Project.
 - a. Photometric data shall be certified by a manufacturer's laboratory with a current accreditation under the National Voluntary Laboratory Accreditation Program (NVLAP) for Energy Efficient Lighting Products.
- B. Shop Drawings: Show details of nonstandard or custom lighting fixtures. Indicate dimensions, weights, methods of field assembly, components, features, and accessories.
 1. Wiring Diagrams: Power and control wiring.
 2. Lighting fixtures.
 3. Suspended ceiling components.
 4. Structural members to which suspension systems for lighting fixtures will be attached.
- C. Samples for Verification: Interior lighting fixtures designated for sample submission in Interior Lighting Fixture Schedule. Each sample shall include the following:
 1. Lamps: Specified units installed.
 2. Accessories: Cords and plugs.
- D. Product Certificates: For each type of ballast for bi-level and dimmer-controlled fixtures, signed by product manufacturer.
- E. Qualification Data: For agencies providing photometric data for lighting fixtures.
- F. Field quality-control test reports.
- G. Operation and Maintenance Data: For lighting equipment and fixtures to include in emergency, operation, and maintenance manuals.
- H. Warranties: Special warranties specified in this Section.

1.5 QUALITY ASSURANCE

- A. Luminaire Photometric Data Testing Laboratory Qualifications: Provided by manufacturers' laboratories that are accredited under the National Volunteer Laboratory Accreditation Program for Energy Efficient Lighting Products.
- B. Luminaire Photometric Data Testing Laboratory Qualifications: Provided by an independent agency, with the experience and capability to conduct the testing indicated, that is an NRTL as defined by OSHA in 29 CFR 1910.7.
- C. Electrical Components, Devices, and Accessories: Listed and labeled as defined in NFPA 70, Article 100, by a testing agency acceptable to authorities having jurisdiction, and marked for intended use.
- D. Comply with NFPA 70.

1.6 COORDINATION

- A. Coordinate layout and installation of lighting fixtures and suspension system with other construction that penetrates ceilings or is supported by them, including HVAC equipment, fire-suppression system, and partition assemblies.

1.7 WARRANTY

- A. Special Warranty for Emergency Lighting Batteries: Manufacturer's standard form in which manufacturer of battery-powered emergency lighting unit agrees to repair or replace components of rechargeable batteries that fail in materials or workmanship within specified warranty period.
 - 1. Warranty Period for Emergency Lighting Unit Batteries: 5 years from date of Substantial Completion. Full warranty shall apply for first year, and prorated warranty for the remaining four years.
 - 2. Warranty Period for Emergency Fluorescent Ballast Batteries: 5 years from date of Substantial Completion. Full warranty shall apply for first year, and prorated warranty for the remaining four years.
- B. Special Warranty for Ballasts: Manufacturer's standard form in which ballast manufacturer agrees to repair or replace ballasts that fail in materials or workmanship within specified warranty period.
 - 1. Warranty Period for Electronic Ballasts: 5 years from date of Substantial Completion.
- C. Special Warranty for T5 and T8 Fluorescent Lamps: Manufacturer's standard form, made out to Owner and signed by lamp manufacturer agreeing to replace lamps that fail in materials or workmanship, f.o.b. the nearest shipping point to Project site, within specified warranty period indicated below.
 - 1. Warranty Period: One year from date of Substantial Completion.

1.8 EXTRA MATERIALS

- A. Furnish extra materials described below that match products installed and that are packaged with protective covering for storage and identified with labels describing contents.
 - 1. Lamps: 10% of total quantity of each type and rating installed. Furnish at least one of each type.
 - 2. Plastic Diffusers and Lenses: 1% of total quantity of each type and rating installed. Furnish at least one of each type.
 - 3. Battery and Charger Data: One> for each emergency lighting unit.
 - 4. Ballasts: 1% of total quantity of each type and rating installed. Furnish at least one of each type.
 - 5. Globes and Guards: 5% of total quantity of each type and rating installed. Furnish at least one of each type.

PART 2 - PRODUCTS

2.1 MANUFACTURERS

- A. In Interior Lighting Fixture Schedule where titles below are column or row headings that introduce lists, the following requirements apply to product selection:
 - 1. Basis-of-Design Product: The design for each lighting fixture is based on the product named.

2.2 LIGHTING FIXTURES AND COMPONENTS, GENERAL REQUIREMENTS

- A. Recessed Fixtures: Comply with NEMA LE 4 for ceiling compatibility for recessed fixtures.
- B. Incandescent Fixtures: Comply with UL 1598. Where LER is specified, test according to NEMA LE 5A.
- C. Fluorescent Fixtures: Comply with UL 1598. Where LER is specified, test according to NEMA LE 5 and NEMA LE 5A as applicable.

- D. HID Fixtures: Comply with UL 1598. Where LER is specified, test according to NEMA LE 5B.
- E. Metal Parts: Free of burrs and sharp corners and edges.
- F. Sheet Metal Components: Steel, unless otherwise indicated. Form and support to prevent warping and sagging.
- G. Doors, Frames, and Other Internal Access: Smooth operating, free of light leakage under operating conditions, and designed to permit relamping without use of tools. Designed to prevent doors, frames, lenses, diffusers, and other components from falling accidentally during relamping and when secured in operating position.
- H. Reflecting surfaces shall have minimum reflectance as follows, unless otherwise indicated:
 - 1. White Surfaces: 85 percent.
 - 2. Specular Surfaces: 83 percent.
 - 3. Diffusing Specular Surfaces: 75 percent.
 - 4. Laminated Silver Metallized Film: 90 percent.
- I. Plastic Diffusers, Covers, and Globes:
 - 1. Acrylic Lighting Diffusers: 100 percent virgin acrylic plastic. High resistance to yellowing and other changes due to aging, exposure to heat, and UV radiation.
 - a. Lens Thickness: At least 0.125 inch (3.175 mm) nominal unless different thickness is indicated.
 - b. UV stabilized.
 - 2. Glass: Annealed crystal glass, unless otherwise indicated.

2.3 BALLASTS FOR LINEAR FLUORESCENT LAMPS

- A. Electronic Ballasts: Comply with ANSI C82.11; instant-start type, unless otherwise indicated, and designed for type and quantity of lamps served. Ballasts shall be designed for full light output unless dimmer or bi-level control is indicated.
 - 1. Sound Rating: A.
 - 2. Total Harmonic Distortion Rating: Less than 10 percent.
 - 3. Transient Voltage Protection: IEEE C62.41, Category A or better.
 - 4. Operating Frequency: 20 kHz or higher.
 - 5. Lamp Current Crest Factor: 1.7 or less.
 - 6. BF: 0.85 or higher.
 - 7. Power Factor: 0.95 or higher.
- B. Electromagnetic Ballasts: Comply with ANSI C82.1; energy saving, high-power factor, Class P, and having automatic-reset thermal protection.
 - 1. Ballast Manufacturer Certification: Indicated by label.
- C. Ballasts for Low-Temperature Environments:
 - 1. Temperatures 0 Deg F (Minus 17 Deg C) and Higher: Electronic type rated for 0 deg F (minus 17 deg C) starting and operating temperature with indicated lamp types.
 - 2. Temperatures Minus 20 Deg F (Minus 29 Deg C) and Higher: Electromagnetic type designed for use with indicated lamp types.
- D. Ballasts for Dimmer-Controlled Lighting Fixtures: Electronic type.

1. Dimming Range: 100 to 5 percent of rated lamp lumens.
2. Ballast Input Watts: Can be reduced to 20 percent of normal.
3. Compatibility: Certified by manufacturer for use with specific dimming control system and lamp type indicated.

2.4 BALLASTS FOR COMPACT FLUORESCENT LAMPS

- A. Description: Electronic programmed rapid-start type, complying with ANSI C 82.11, designed for type and quantity of lamps indicated. Ballast shall be designed for full light output unless dimmer or bi-level control is indicated:

1. Lamp end-of-life detection and shutdown circuit.
2. Automatic lamp starting after lamp replacement.
3. Sound Rating: A.
4. Total Harmonic Distortion Rating: Less than 20 percent.
5. Transient Voltage Protection: IEEE C62.41, Category A or better.
6. Operating Frequency: 20 kHz or higher.
7. Lamp Current Crest Factor: 1.7 or less.
8. BF: 0.95 or higher, unless otherwise indicated.
9. Power Factor: 0.98 or higher.
10. Interference: Comply with 47 CFR, Chapter 1, Part 18, Subpart C, for limitations on electromagnetic and radio-frequency interference for nonconsumer equipment.
11. Ballast Case Temperature: 75 deg C, maximum.

- B. Ballasts for Dimmer-Controlled Lighting Fixtures: Electronic type.

1. Dimming Range: 100 to 5 percent of rated lamp lumens.
2. Ballast Input Watts: Can be reduced to 20 percent of normal.
3. Compatibility: Certified by manufacturer for use with specific dimming control system and lamp type indicated.

2.5 EMERGENCY FLUORESCENT POWER UNIT

- A. Internal Type: Self-contained, modular, battery-inverter unit, factory mounted within lighting fixture body and compatible with ballast. Comply with UL 924.

1. Emergency Connection: Operate 1 fluorescent lamp(s) continuously at an output of 1400 lumens each. Connect unswitched circuit to battery-inverter unit and switched circuit to fixture ballast.
2. Night-Light Connection: Operate one fluorescent lamp continuously.
3. Test Push Button and Indicator Light: Visible and accessible without opening fixture or entering ceiling space.
 - a. Push Button: Push-to-test type, in unit housing, simulates loss of normal power and demonstrates unit operability.
 - b. Indicator Light: LED indicates normal power on. Normal glow indicates trickle charge; bright glow indicates charging at end of discharge cycle.
4. Battery: Sealed, maintenance-free, nickel-cadmium type.
5. Charger: Fully automatic, solid-state, constant-current type with sealed power transfer relay.
6. Remote Test: Switch in hand-held remote device aimed in direction of tested unit initiates coded infrared signal. Signal reception by factory-installed infrared receiver in tested unit triggers simulation of loss of its normal power supply, providing visual confirmation of either proper or failed emergency response.
7. Integral Self-Test: Factory-installed electronic device automatically initiates code-required test of unit emergency operation at required intervals. Test failure is annunciated by an integral audible alarm and flashing red LED.

- B. External Type: Self-contained, modular, battery-inverter unit, suitable for powering one or more fluorescent lamps, remote mounted from lighting fixture. Comply with UL 924.
 - 1. Emergency Connection: Operate one fluorescent lamp continuously. Connect unswitched circuit to battery-inverter unit and switched circuit to fixture ballast.
 - 2. Night-Light Connection: Operate one fluorescent lamp in a remote fixture continuously.
 - 3. Battery: Sealed, maintenance-free, nickel-cadmium type.
 - 4. Charger: Fully automatic, solid-state, constant-current type.
 - 5. Housing: NEMA 250, Type 1 enclosure.
 - 6. Test Push Button: Push-to-test type, in unit housing, simulates loss of normal power and demonstrates unit operability.
 - 7. LED Indicator Light: Indicates normal power on. Normal glow indicates trickle charge; bright glow indicates charging at end of discharge cycle.
 - 8. Integral Self-Test: Factory-installed electronic device automatically initiates code-required test of unit emergency operation at required intervals. Test failure is annunciated by an integral audible alarm and flashing red LED.

2.6 BALLASTS FOR HID LAMPS

- A. Electromagnetic Ballast for Metal-Halide Lamps: Comply with ANSI C82.4 and UL 1029. Include the following features, unless otherwise indicated:
 - 1. Ballast Circuit: Constant-wattage autotransformer or regulating high-power-factor type.
 - 2. Minimum Starting Temperature: Minus 22 deg F (Minus 30 deg C) for single-lamp ballasts.
 - 3. Normal Ambient Operating Temperature: 104 deg F (40 deg C).
 - 4. Open-circuit operation that will not reduce average life.
 - 5. Low-Noise Ballasts: Manufacturers' standard epoxy-encapsulated models designed to minimize audible fixture noise.
- B. Electronic Ballast for Metal-Halide Lamps: Include the following features unless otherwise indicated:
 - 1. Lamp end-of-life detection and shutdown circuit.
 - 2. Sound Rating: A.
 - 3. Total Harmonic Distortion Rating: Less than 15 percent.
 - 4. Transient Voltage Protection: IEEE C62.41, Category A or better.
 - 5. Lamp Current Crest Factor: 1.5 or less.
 - 6. Power Factor: .90 or higher.
 - 7. Interference: Comply with 47 CFR, Chapter 1, Part 18, Subpart C, for limitations on electromagnetic and radio-frequency interference for nonconsumer equipment.
 - 8. Protection: Class P thermal cutout.
 - 9. Retain subparagraph and associated subparagraphs below for bi-level ballasts.
- C. Auxiliary Instant-On Quartz System: Factory-installed feature automatically switches quartz lamp on when fixture is initially energized and when power outages occur. System automatically turns quartz lamp off when HID lamp reaches approximately 60 percent light output.

2.7 EXIT SIGNS

- A. Description: Comply with UL 924; for sign colors, visibility, luminance, and lettering size, comply with authorities having jurisdiction.
- B. Internally Lighted Signs:
 - 1. Lamps for AC Operation: LEDs, 70,000 hours minimum rated lamp life.
 - 2. Self-Powered Exit Signs (Battery Type): Integral automatic charger in a self-contained power pack.
 - a. Battery: Sealed, maintenance-free, nickel-cadmium type.
 - b. Charger: Fully automatic, solid-state type with sealed transfer relay.

- c. Operation: Relay automatically energizes lamp from battery when circuit voltage drops to 80 percent of nominal voltage or below. When normal voltage is restored, relay disconnects lamps from battery, and battery is automatically recharged and floated on charger.
- d. Test Push Button: Push-to-test type, in unit housing, simulates loss of normal power and demonstrates unit operability.
- e. LED Indicator Light: Indicates normal power on. Normal glow indicates trickle charge; bright glow indicates charging at end of discharge cycle.
- f. Integral Self-Test: Factory-installed electronic device automatically initiates code-required test of unit emergency operation at required intervals. Test failure is annunciated by an integral audible alarm and flashing red LED.

2.8 FLUORESCENT LAMPS

- A. Low-Mercury Lamps: Comply with EPA's toxicity characteristic leaching procedure test; shall yield less than 0.2 mg of mercury per liter when tested according to NEMA LL 1.
- B. T8 rapid-start low-mercury lamps, rated 32 W maximum, nominal length of 48 inches (1220 mm), 2800 initial lumens (minimum), CRI 75 (minimum), color temperature 3500 K, and average rated life 20,000 hours, unless otherwise indicated.
- C. T8 rapid-start low-mercury lamps, rated 17 W maximum, nominal length of 24 inches (610 mm), 1300 initial lumens (minimum), CRI 75 (minimum), color temperature 3500 K, and average rated life of 20,000 hours, unless otherwise indicated.
- D. T5 rapid-start low-mercury lamps, rated 28 W maximum, nominal length of 45.2 inches (1150 mm), 2900 initial lumens (minimum), CRI 85 (minimum), color temperature 3500 K, and average rated life of 20,000 hours, unless otherwise indicated.
- E. T5HO rapid-start, high-output low-mercury lamps, rated 54 W maximum, nominal length of 45.2 inches (1150 mm), 5000 initial lumens (minimum), CRI 85 (minimum), color temperature 3500 K, and average rated life of 20,000 hours, unless otherwise indicated.
- F. Compact Fluorescent Lamps: 4-Pin, low mercury, CRI 80 (minimum), color temperature 3500 K, average rated life of 10,000 hours at 3 hours operation per start, and suitable for use with dimming ballasts, where indicated unless otherwise indicated.
 - 1. 13 W: T4, double or triple tube, rated 900 initial lumens (minimum).
 - 2. 18 W: T4, double or triple tube, rated 1200 initial lumens (minimum).
 - 3. 26 W: T4, double or triple tube, rated 1800 initial lumens (minimum).
 - 4. 32 W: T4, triple tube, rated 2400 initial lumens (minimum).
 - 5. 42 W: T4, triple tube, rated 3200 initial lumens (minimum).
 - 6. 55 W: T4, triple tube, rated 4300 initial lumens (minimum).

2.9 HID LAMPS

- A. Pulse-Start, Metal-Halide Lamps: Minimum CRI 65, and color temperature 4000 K.

2.10 LIGHTING FIXTURE SUPPORT COMPONENTS

- A. Comply with Division 26 Section "Hangers and Supports for Electrical Systems" for channel- and angle-iron supports and nonmetallic channel and angle supports.
- B. Single-Stem Hangers: 1/2-inch (13-mm) steel tubing with swivel ball fittings and ceiling canopy. Finish same as fixture.

- C. Twin-Stem Hangers: Two, 1/2-inch (13-mm) steel tubes with single canopy designed to mount a single fixture. Finish same as fixture.
- D. Wires: ASTM A 641/A 641M, Class 3, soft temper, zinc-coated steel, 12 gage (2.68 mm).
- E. Wires for Humid Spaces: ASTM A 580/A 580M, Composition 302 or 304, annealed stainless steel, 12 gage (2.68 mm).
- F. Rod Hangers: 3/16-inch (5-mm) minimum diameter, cadmium-plated, threaded steel rod.
- G. Hook Hangers: Integrated assembly matched to fixture and line voltage and equipped with threaded attachment, cord, and locking-type plug.

PART 3 - EXECUTION

3.1 INSTALLATION

- A. Lighting fixtures: Set level, plumb, and square with ceilings and walls. Install lamps in each fixture.
- B. Support for Lighting Fixtures in or on Grid-Type Suspended Ceilings: Use grid as a support element.
 - 1. Install a minimum of four ceiling support system rods or wires for each fixture. Locate not more than 6 inches (150 mm) from lighting fixture corners.
 - 2. Support Clips: Fasten to lighting fixtures and to ceiling grid members at or near each fixture corner with clips that are UL listed for the application.
 - 3. Fixtures of Sizes Less Than Ceiling Grid: Install as indicated on reflected ceiling plans or center in acoustical panel, and support fixtures independently with at least two 3/4-inch (20-mm) metal channels spanning and secured to ceiling tees.
 - 4. Install at least one independent support rod or wire from structure to a tab on lighting fixture. Wire or rod shall have breaking strength of the weight of fixture at a safety factor of 3.
- C. Suspended Lighting Fixture Support:
 - 1. Pendants and Rods: Where longer than 48 inches (1200 mm), brace to limit swinging.
 - 2. Stem-Mounted, Single-Unit Fixtures: Suspend with twin-stem hangers.
 - 3. Continuous Rows: Use tubing or stem for wiring at one point and tubing or rod for suspension for each unit length of fixture chassis, including one at each end.
- D. Adjust aimable lighting fixtures to provide required light intensities. Re-aim until best performance is obtained.
- E. Connect wiring according to Division 26 Section "Low-Voltage Electrical Power Conductors and Cables."

3.2 FIELD QUALITY CONTROL

- A. Test for Emergency Lighting: Interrupt power supply to demonstrate proper operation. Verify transfer from normal power to battery and retransfer to normal.
- B. Prepare a written report of tests, inspections, observations, and verifications indicating and interpreting results. If adjustments are made to lighting system, retest to demonstrate compliance with standards.

END OF SECTION 265100

SECTION 283111 - DIGITAL, ADDRESSABLE FIRE-ALARM SYSTEM

PART 1 - GENERAL

1.1 RELATED DOCUMENTS

- A. Drawings and general provisions of the Contract, including General and Supplementary Conditions and Division 01 Specification Sections, apply to this Section.

1.2 SUMMARY

- A. Section Includes:
 - 1. Fire-alarm control unit.
 - 2. Manual fire-alarm boxes.
 - 3. System smoke detectors.
 - 4. Heat detectors.
 - 5. Notification appliances.
 - 6. Remote annunciator.
 - 7. Addressable interface device.
 - 8. Digital alarm communicator transmitter.

1.3 DEFINITIONS

- A. LED: Light-emitting diode.
- B. NICET: National Institute for Certification in Engineering Technologies.

1.4 SYSTEM DESCRIPTION

- A. Noncoded, UL-certified addressable system, with multiplexed signal transmission, dedicated to fire-alarm service only.

1.5 PERFORMANCE REQUIREMENTS

- A. Seismic Performance: Fire-alarm control unit and raceways shall withstand the effects of earthquake motions determined according to SEI/ASCE 7.
 - 1. The term "withstand" means "the unit will remain in place without separation of any parts from the device when subjected to the seismic forces specified and the unit will be fully operational after the seismic event."

1.6 SUBMITTALS

- A. General Submittal Requirements:
 - 1. Submittals shall be approved by authorities having jurisdiction prior to submitting them to Architect.
 - 2. Shop Drawings shall be prepared by persons with the following qualifications:

- a. Trained and certified by manufacturer in fire-alarm system design.
 - b. NICET-certified fire-alarm technician, Level III minimum.
- B. Product Data: For each type of product indicated.
- C. Shop Drawings: For fire-alarm system. Include plans, elevations, sections, details, and attachments to other work.
1. Comply with recommendations in the "Documentation" Section of the "Fundamentals of Fire Alarm Systems" Chapter in NFPA 72, 2010 Edition.
 2. Include voltage drop calculations for notification appliance circuits.
 3. Include battery-size calculations.
 4. Include performance parameters and installation details for each detector, verifying that each detector is listed for complete range of air velocity, temperature, and humidity possible when air-handling system is operating.
 5. Include plans, sections, and elevations of heating, ventilating, and air-conditioning ducts, drawn to scale and coordinating installation of duct smoke detectors and access to them. Show critical dimensions that relate to placement and support of sampling tubes, detector housing, and remote status and alarm indicators. Locate detectors according to manufacturer's written recommendations.
 6. Include floor plans to indicate final outlet locations showing address of each addressable device. Show size and route of cable and conduits.
- D. Delegated-Design Submittal: For smoke and heat detectors indicated to comply with performance requirements and design criteria, including analysis data signed and sealed by the qualified professional engineer responsible for their preparation.
1. Drawings showing the location of each smoke and heat detector, ratings of each, and installation details as needed to comply with listing conditions of the detector.
 2. Design Calculations: Calculate requirements for selecting the spacing and sensitivity of detection, complying with NFPA 72, 2010 Edition.
- E. Qualification Data: For qualified Installer.
- F. Seismic Qualification Certificates: For fire-alarm control unit, accessories, and components, from manufacturer.
1. Basis for Certification: Indicate whether withstand certification is based on actual test of assembled components or on calculation.
 2. Dimensioned Outline Drawings of Equipment Unit: Identify center of gravity and locate and describe mounting and anchorage provisions.
 3. Detailed description of equipment anchorage devices on which the certification is based and their installation requirements.
- G. Field quality-control reports.
- H. Operation and Maintenance Data: For fire-alarm systems and components to include in emergency, operation, and maintenance manuals. In addition to items specified in Division 01 Section "Operation and Maintenance Data," include the following:
1. Comply with the "Records" Section of the "Inspection, Testing and Maintenance" Chapter in NFPA 72, 2010 Edition.
 2. Provide "Record of Completion Documents" according to NFPA 72, 2010 Edition article "Permanent Records" in the "Records" Section of the "Inspection, Testing and Maintenance" Chapter.
 3. Record copy of site-specific software.
 4. Provide "Maintenance, Inspection and Testing Records" according to NFPA 72, 2010 Edition article of the same name and include the following:

- a. Frequency of testing of installed components.
 - b. Frequency of inspection of installed components.
 - c. Requirements and recommendations related to results of maintenance.
 - d. Manufacturer's user training manuals.
5. Manufacturer's required maintenance related to system warranty requirements.
 6. Abbreviated operating instructions for mounting at fire-alarm control unit.

1.7 QUALITY ASSURANCE

- A. Installer Qualifications: Personnel shall be trained and certified by manufacturer for installation of units required for this Project.
- B. Source Limitations for Fire-Alarm System and Components: Obtain fire-alarm system from single source from single manufacturer. Components shall be compatible with, and operate as, an extension of existing system.
- C. Electrical Components, Devices, and Accessories: Listed and labeled as defined in NFPA 70, 2010 Edition, by a qualified testing agency, and marked for intended location and application. Retain one of four paragraphs below to require independent system verification.

1.8 PROJECT CONDITIONS

1.9 EXTRA MATERIALS

- A. Furnish extra materials that match products installed and that are packaged with protective covering for storage and identified with labels describing contents.
 1. Lamps for Remote Indicating Lamp Units: Quantity equal to 10 percent of amount installed, but no fewer than 1 unit.
 2. Lamps for Strobe Units: Quantity equal to 10 percent of amount installed, but no fewer than 1 unit.
 3. Smoke Detectors: Quantity equal to percent of amount of each type installed, but no fewer than 1 unit of each type.
 4. Detector Bases: Quantity equal to 2 percent of amount of each type installed, but no fewer than 1 unit of each type.
 5. Keys and Tools: One extra set for access to locked and tamperproofed components.
 6. Audible and Visual Notification Appliances: One of each type installed.
 7. Fuses: Two of each type installed in the system.

PART 2 - PRODUCTS

2.1 MANUFACTURERS

- A. Manufacturers: Subject to compliance with requirements, available manufacturers offering products that may be incorporated into the Work include, but are not limited to, the following:
 1. Simplex or equal
 2. Honeywell or equal
 3. Johnson Controls or equal

2.2 SYSTEMS OPERATIONAL DESCRIPTION

- A. Fire-alarm signal initiation shall be by one or more of the following devices and systems:
1. Manual stations.
 2. Heat detectors.
 3. Smoke detectors.
 4. Duct mounted smoke detectors.
- B. Fire-alarm signal shall initiate the following actions:
1. Continuously operate alarm notification appliances.
 2. Identify alarm at fire-alarm control unit and remote annunciators.
 3. Transmit an alarm signal to the remote alarm receiving station.
 4. Unlock electric door locks in designated egress paths.
 5. Release fire and smoke doors held open by magnetic door holders.
 6. Switch heating, ventilating, and air-conditioning equipment controls to fire-alarm mode.
 7. Record events in the system memory.
- C. Supervisory signal initiation shall be by one or more of the following devices and actions:
1. Valve supervisory switch.
- D. System trouble signal initiation shall be by one or more of the following devices and actions:
1. Open circuits, shorts, and grounds in designated circuits.
 2. Opening, tampering with, or removing alarm-initiating and supervisory signal-initiating devices.
 3. Loss of primary power at fire-alarm control unit.
 4. Ground or a single break in fire-alarm control unit internal circuits.
 5. Abnormal ac voltage at fire-alarm control unit.
 6. Break in standby battery circuitry.
 7. Failure of battery charging.
 8. Abnormal position of any switch at fire-alarm control unit or annunciator.
- E. System Trouble and Supervisory Signal Actions: Initiate notification appliance and annunciate at fire-alarm control unit and remote annunciators. Record the event on system printer.

2.3 FIRE-ALARM CONTROL UNIT

- A. General Requirements for Fire-Alarm Control Unit:
1. Field-programmable, microprocessor-based, modular, power-limited design with electronic modules, complying with UL 864 and listed and labeled by an NRTL.
 - a. System software and programs shall be held in flash electrically erasable programmable read-only memory (EEPROM), retaining the information through failure of primary and secondary power supplies.
 - b. Include a real-time clock for time annotation of events on the event recorder and printer.
 2. Addressable initiation devices that communicate device identity and status.
 - a. Smoke sensors shall additionally communicate sensitivity setting and allow for adjustment of sensitivity at fire-alarm control unit.
 - b. Temperature sensors shall additionally test for and communicate the sensitivity range of the device.
 3. Addressable control circuits for operation of mechanical equipment.

- B. Alphanumeric Display and System Controls: Arranged for interface between human operator at fire-alarm control unit and addressable system components including annunciation and supervision. Display alarm, supervisory, and component status messages and the programming and control menu.
 - 1. Annunciator and Display: Liquid-crystal type, 3 line(s) of 80 characters, minimum.
 - 2. Keypad: Arranged to permit entry and execution of programming, display, and control commands and to indicate control commands to be entered into the system for control of smoke-detector sensitivity and other parameters.

- C. Circuits:
 - 1. Initiating Device, Notification Appliance, and Signaling Line Circuits: NFPA 72, 2010 Edition, Class A.
 - a. Initiating Device Circuits.
 - b. Notification Appliance Circuits.
 - c. Signaling Line Circuits.
 - d. Install no more than 25 addressable devices on each signaling line circuit.
 - 2. Serial Interfaces: One RS-232 port.

- D. Transmission to Remote Alarm Receiving Station: Automatically transmit alarm, supervisory, and trouble signals to a remote alarm station.

- E. Primary Power: 24-V dc obtained from 120-V ac service and a power-supply module. Initiating devices, notification appliances, signaling lines, trouble signals, supervisory signals, supervisory and digital alarm communicator transmitters shall be powered by 24-V dc source.
 - 1. Alarm current draw of entire fire-alarm system shall not exceed 80 percent of the power-supply module rating.

- F. Secondary Power: 24-V dc supply system with batteries, automatic battery charger, and automatic transfer switch.
 - 1. Batteries: Sealed, valve-regulated, recombinant lead acid.

2.4 MANUAL FIRE-ALARM BOXES

- A. General Requirements for Manual Fire-Alarm Boxes: Comply with UL 38. Boxes shall be finished in red with molded, raised-letter operating instructions in contrasting color; shall show visible indication of operation; and shall be mounted on recessed outlet box. If indicated as surface mounted, provide manufacturer's surface back box.
 - 1. Single-action mechanism, pull-lever type; with integral addressable module arranged to communicate manual-station status (normal, alarm, or trouble) to fire-alarm control unit.
 - 2. Station Reset: Key- or wrench-operated switch.

2.5 SYSTEM SMOKE DETECTORS

- A. General Requirements for System Smoke Detectors:
 - 1. Comply with UL 268; operating at 24-V dc, nominal.
 - 2. Detectors shall be two-wire type.
 - 3. Integral Addressable Module: Arranged to communicate detector status (normal, alarm, or trouble) to fire-alarm control unit.

4. Base Mounting: Detector and associated electronic components shall be mounted in a twist-lock module that connects to a fixed base. Provide terminals in the fixed base for connection to building wiring.
 5. Self-Restoring: Detectors do not require resetting or readjustment after actuation to restore them to normal operation.
 6. Integral Visual-Indicating Light: LED type indicating detector has operated and power-on status.
 7. Remote Control: Unless otherwise indicated, detectors shall be analog-addressable type, individually monitored at fire-alarm control unit for calibration, sensitivity, and alarm condition and individually adjustable for sensitivity by fire-alarm control unit.
 - a. Rate-of-rise temperature characteristic shall be selectable at fire-alarm control unit for 15 or 20 deg F (8 or 11 deg C) per minute.
 - b. Fixed-temperature sensing shall be independent of rate-of-rise sensing and shall be settable at fire-alarm control unit to operate at 135 or 155 deg F (57 or 68 deg C).
 - c. Provide multiple levels of detection sensitivity for each sensor.
- B. Photoelectric Smoke Detectors:
1. Detector address shall be accessible from fire-alarm control unit and shall be able to identify the detector's location within the system and its sensitivity setting.
 2. An operator at fire-alarm control unit, having the designated access level, shall be able to manually access the following for each detector:
 - a. Primary status.
 - b. Device type.
 - c. Present average value.
 - d. Present sensitivity selected.
 - e. Sensor range (normal, dirty, etc.).
- C. Ionization Smoke Detector:
1. Detector address shall be accessible from fire-alarm control unit and shall be able to identify the detector's location within the system and its sensitivity setting.
 2. An operator at fire-alarm control unit, having the designated access level, shall be able to manually access the following for each detector:
 - a. Primary status.
 - b. Device type.
 - c. Present average value.
 - d. Present sensitivity selected.
 - e. Sensor range (normal, dirty, etc.).
- D. Duct Smoke Detectors: Photoelectric type complying with UL 268A.
1. Detector address shall be accessible from fire-alarm control unit and shall be able to identify the detector's location within the system and its sensitivity setting.
 2. An operator at fire-alarm control unit, having the designated access level, shall be able to manually access the following for each detector:
 - a. Primary status.
 - b. Device type.
 - c. Present average value.
 - d. Present sensitivity selected.
 - e. Sensor range (normal, dirty, etc.).
 3. Weatherproof Duct Housing Enclosure: NEMA 250, Type 4X; NRTL listed for use with the supplied detector.
 4. Each sensor shall have multiple levels of detection sensitivity.
 5. Sampling Tubes: Design and dimensions as recommended by manufacturer for specific duct size, air velocity, and installation conditions where applied.

6. Relay Fan Shutdown: Rated to interrupt fan motor-control circuit.

2.6 HEAT DETECTORS

- A. General Requirements for Heat Detectors: Comply with UL 521.
- B. Heat Detector, Combination Type: Actuated by either a fixed temperature of 135 deg F (57 deg C) or a rate of rise that exceeds 15 deg F (8 deg C) per minute unless otherwise indicated.
 1. Mounting: Twist-lock base interchangeable with smoke-detector bases.
 2. Integral Addressable Module: Arranged to communicate detector status (normal, alarm, or trouble) to fire-alarm control unit.
- C. Heat Detector, Fixed-Temperature Type: Actuated by temperature that exceeds a fixed temperature of 190 deg F (88 deg C).
 1. Mounting: Twist-lock base interchangeable with smoke-detector bases.
 2. Integral Addressable Module: Arranged to communicate detector status (normal, alarm, or trouble) to fire-alarm control unit.

2.7 NOTIFICATION APPLIANCES

- A. General Requirements for Notification Appliances: Individually addressed, connected to a signaling line circuit, equipped for mounting as indicated and with screw terminals for system connections.
- B. General Requirements for Notification Appliances: Connected to notification appliance signal circuits, zoned as indicated, equipped for mounting as indicated and with screw terminals for system connections.
 1. Combination Devices: Factory-integrated audible and visible devices in a single-mounting assembly, equipped for mounting as indicated and with screw terminals for system connections.
- C. Chimes, Low-Level Output: Vibrating type, 75-dBA minimum rated output.
- D. Chimes, High-Level Output: Vibrating type, 81-dBA minimum rated output.
- E. Horns: Electric-vibrating-polarized type, 24-V dc; with provision for housing the operating mechanism behind a grille. Comply with UL 464. Horns shall produce a sound-pressure level of 90 dBA, measured 10 feet (3 m) from the horn, using the coded signal prescribed in UL 464 test protocol.
- F. Visible Notification Appliances: Xenon strobe lights comply with UL 1971, with clear or nominal white polycarbonate lens mounted on an aluminum faceplate. The word "FIRE" is engraved in minimum 1-inch-(25-mm-) high letters on the lens.
 1. Rated Light Output:
 - a. 15/30/75/110 cd, selectable in the field.
 2. Mounting: Wall mounted unless otherwise indicated.
 3. For units with guards to prevent physical damage, light output ratings shall be determined with guards in place.
 4. Flashing shall be in a temporal pattern, synchronized with other units.
 5. Strobe Leads: Factory connected to screw terminals.
 6. Mounting Faceplate: Factory finished, red.

2.8 REMOTE ANNUNCIATOR

- A. Description: Annunciator functions shall match those of fire-alarm control unit for alarm, supervisory, and trouble indications. Manual switching functions shall match those of fire-alarm control unit, including acknowledging, silencing, resetting, and testing.
 - 1. Mounting: Flush cabinet, NEMA 250, Type 1.
- B. Display Type and Functional Performance: Alphanumeric display and LED indicating lights shall match those of fire-alarm control unit. Provide controls to acknowledge, silence, reset, and test functions for alarm, supervisory, and trouble signals.

2.9 ADDRESSABLE INTERFACE DEVICE

- A. Description: Microelectronic monitor module, NRTL listed for use in providing a system address for alarm-initiating devices for wired applications with normally open contacts.

2.10 DIGITAL ALARM COMMUNICATOR TRANSMITTER

- A. Digital alarm communicator transmitter shall be acceptable to the remote central station and shall comply with UL 632 and be listed and labeled by an NRTL.
- B. Functional Performance: Unit shall receive an alarm, supervisory, or trouble signal from fire-alarm control unit and automatically capture two telephone line(s) and dial a preset number for a remote central station. When contact is made with central station(s), signals shall be transmitted. If service on line is interrupted for longer than 45 seconds, transmitter shall initiate a local trouble signal and transmit the signal indicating loss of telephone line to the remote alarm receiving station over the remaining line. Transmitter shall automatically report telephone service restoration to the central station. If service is lost on both telephone lines, transmitter shall initiate the local trouble signal.
- C. Local functions and display at the digital alarm communicator transmitter shall include the following:
 - 1. Verification that both telephone lines are available.
 - 2. Programming device.
 - 3. LED display.
 - 4. Manual test report function and manual transmission clear indication.
 - 5. Communications failure with the central station or fire-alarm control unit.
- D. Digital data transmission shall include the following:
 - 1. Address of the alarm-initiating device.
 - 2. Address of the supervisory signal.
 - 3. Address of the trouble-initiating device.
 - 4. Loss of ac supply or loss of power.
 - 5. Low battery.
 - 6. Abnormal test signal.
 - 7. Communication bus failure.
- E. Secondary Power: Integral rechargeable battery and automatic charger.
- F. Self-Test: Conducted automatically every 24 hours with report transmitted to central station.

PART 3 - EXECUTION

3.1 EQUIPMENT INSTALLATION

- A. Comply with NFPA 72, 2010 EDITION for installation of fire-alarm equipment.
 - 1. Comply with requirements for seismic-restraint devices specified in Division 26 Section "Vibration and Seismic Controls for Electrical Systems."
 - 2. Comply with requirements for seismic-restraint devices specified in Division 26 Section "Vibration and Seismic Controls for Electrical Systems."
- B. Smoke- or Heat-Detector Spacing:
 - 1. Comply with NFPA 72, 2010 Edition, "Smoke-Sensing Fire Detectors" Section in the "Initiating Devices" Chapter, for smoke-detector spacing.
 - 2. Comply with NFPA 72, 2010 Edition, "Heat-Sensing Fire Detectors" Section in the "Initiating Devices" Chapter, for heat-detector spacing.
 - 3. Smooth ceiling spacing shall not exceed 30 feet (9 m).
 - 4. Spacing of detectors for irregular areas, for irregular ceiling construction, and for high ceiling areas shall be determined according to Appendix A or Appendix B in NFPA 72, 2010 EDITION.
 - 5. HVAC: Locate detectors not closer than [3 feet (1 m)] [5 feet (1.5 m)] from air-supply diffuser or return-air opening.
 - 6. Lighting Fixtures: Locate detectors not closer than 12 inches (300 mm) from any part of a lighting fixture.
- C. Duct Smoke Detectors: Comply with NFPA 72, 2010 Edition and NFPA 90A. Install sampling tubes so they extend the full width of duct.
- D. Remote Status and Alarm Indicators: Install near each smoke detector and each sprinkler water-flow switch and valve-tamper switch that is not readily visible from normal viewing position.
- E. Audible Alarm-Indicating Devices: Install not less than 6 inches (150 mm) below the ceiling. Install bells and horns on flush-mounted back boxes with the device-operating mechanism concealed behind a grille.
- F. Visible Alarm-Indicating Devices: Install adjacent to each alarm bell or alarm horn and at least 6 inches (150 mm) below the ceiling.
- G. Device Location-Indicating Lights: Locate in public space near the device they monitor.
- H. Fire-Alarm Control Unit: Surface mounted, with tops of cabinets not more than 72 inches (1830 mm) above the finished floor.
- I. Annunciator: Install with top of panel not more than 72 inches (1830 mm) above the finished floor.

3.2 IDENTIFICATION

- A. Identify system components, wiring, cabling, and terminals. Comply with requirements for identification specified in Division 26 Section "Identification for Electrical Systems."
- B. Install framed instructions in a location visible from fire-alarm control unit.

3.3 GROUNDING

- A. Ground fire-alarm control unit and associated circuits; comply with IEEE 1100. Install a ground wire from main service ground to fire-alarm control unit.

3.4 FIELD QUALITY CONTROL

- A. Perform tests and inspections.
 - 1. Manufacturer's Field Service: Engage a factory-authorized service representative to inspect components, assemblies, and equipment installations, including connections, and to assist in testing.
- B. Tests and Inspections:
 - 1. Visual Inspection: Conduct visual inspection prior to testing.
 - a. Inspection shall be based on completed Record Drawings and system documentation that is required by NFPA 72, 2010 Edition in its "Completion Documents, Preparation" Table in the "Documentation" Section of the "Fundamentals of Fire Alarm Systems" Chapter.
 - b. Comply with "Visual Inspection Frequencies" Table in the "Inspection" Section of the "Inspection, Testing and Maintenance" Chapter in NFPA 72, 2010 EDITION; retain the "Initial/Reacceptance" column and list only the installed components.
 - 2. System Testing: Comply with "Test Methods" Table in the "Testing" Section of the "Inspection, Testing and Maintenance" Chapter in NFPA 72, 2010 Edition.
 - 3. Test audible appliances for the public operating mode according to manufacturer's written instructions. Perform the test using a portable sound-level meter complying with Type 2 requirements in ANSI S1.4.
 - 4. Test audible appliances for the private operating mode according to manufacturer's written instructions.
 - 5. Test visible appliances for the public operating mode according to manufacturer's written instructions.
 - 6. Factory-authorized service representative shall prepare the "Fire Alarm System Record of Completion" in the "Documentation" Section of the "Fundamentals of Fire Alarm Systems" Chapter in NFPA 72, 2010 Edition and the "Inspection and Testing Form" in the "Records" Section of the "Inspection, Testing and Maintenance" Chapter in NFPA 72, 2010 Edition.
- C. Reacceptance Testing: Perform reacceptance testing to verify the proper operation of added or replaced devices and appliances.
- D. Fire-alarm system will be considered defective if it does not pass tests and inspections.
- E. Prepare test and inspection reports.
- F. Maintenance Test and Inspection: Perform tests and inspections listed for weekly, monthly, quarterly, and semiannual periods. Use forms developed for initial tests and inspections.
- G. Annual Test and Inspection: One year after date of Substantial Completion, test fire-alarm system complying with visual and testing inspection requirements in NFPA 72, 2010 Edition. Use forms developed for initial tests and inspections.

3.5 DEMONSTRATION

- A. Train Owner's maintenance personnel to adjust, operate, and maintain fire-alarm system.

END OF SECTION 283111